



SIGMA 110/SIGMA 330

Operator Manual

(Software Version V 5.XX)

© Copyright by KONTRON MEDICAL, 2001

GENERAL INFORMATION

I. Copyright

© 2001 by KONTRON MEDICAL SAS
ALL RIGHTS RESERVED
PRINTED IN FRANCE

The information contained in this publication may not be used for any purpose other than that for which it was originally supplied. The publication may not be reproduced in part or in whole without written consent of KONTRON MEDICAL SAS. In order to maintain and improve standards of manufacturing, methods of functioning and reliability, KONTRON MEDICAL SAS equipments are periodically reviewed. For this reason, the content of this publication is subject to change without any notice.

This product contains KONTRON MEDICAL' proprietary software in machine-readable form. KONTRON MEDICAL SAS retains all its rights, title and interest in the software. Purchase of this product includes a license to use the software contained in it. The purchaser shall not copy, trace, disassemble or modify the software, nor cause or allow this software to be copied, traced, disassembled or modified. Transfer of this product by the purchaser will constitute a transfer of this license, which will not be transferable otherwise.

The equipment described is manufactured by:

KONTRON MEDICAL S.A.S.
Boite Postale 97
78373 PLAISIR CEDEX
FRANCE

Internet: www.kontronmedical.com

Apple, Macintosh, iMac, MacOS, FireWire are registered trademarks of Apple Computer, Inc.

Intel[®], Pentium[®] and Pentium III[®] are registered trademarks of Intel Corporation.

Linux is a registered trademark of Linus Torvalds.

Matrox[®] is a registered trademark of Matrox Electronic Systems Ltd.

Microsoft[®] and Windows[®] are registered trademarks of Microsoft Corporation.

USB is a registered trademark of USB Implementers Forum, Inc.

Sono**Win**[®], Sono**Winlite**[®] and Sono**Winbasic**[®] are registered trademarks of Meso.

II. Quality, Reliability and Safety

This equipment has been designed with high standards of quality, reliability and safety. KONTRON MEDICAL SAS can however only accept the corresponding manufacturer's responsibility providing the following conditions are met: Electrical installations of the room or building in which the equipment is to be used must comply with the relevant national regulations. The equipment is used in accordance with the instructions for use provided by KONTRON MEDICAL SAS (Operator manual). All modifications and repairs to the equipment are carried out by authorized KONTRON MEDICAL personnel, or their agents. The equipment must comply with regulations specified in the "Safety Informations" section.

Your local KONTRON MEDICAL company or agent is: (To be filled by local KONTRON MEDICAL company or agent.)

A large, empty rectangular box with a thin black border, intended for the user to fill in the name of their local KONTRON MEDICAL company or agent.

TABLE OF CONTENTS

I. Copyright.....	iii
II. Quality, Reliability and Safety.....	iv
III. Intended Clinical Use and Safety Information	xv
IV. Compliance with Standards.....	xxx
1. INSTRUMENT DESCRIPTION	1-1
1.1 Introduction.....	1-3
1.2 SIGMA 110/330 Equipments	1-5
1.3 Physical Description	1-7
1.3.1 Electronic Cabinet.....	1-11
1.3.2 Control Panel	1-11
1.3.3 TV Monitor	1-15
1.3.4 Front Panel	1-17
1.3.5 Rear Panel.....	1-22
1.4 System Controls	1-28
1.4.1 Alphanumeric Keys.....	1-28
1.4.2 Live Investigation Keys	1-29
1.4.3 Keys for Frozen Image Study.....	1-30
1.4.4 Trackball.....	1-31
1.5 Screen Layout	1-33
1.5.1 Ultrasound Screen Layout	1-33
1.5.2 Menu.....	1-36
1.5.3 Technical Data Area.....	1-38
1.6 Display Modes	1-42
1.6.1 2D Modes	1-42
1.6.2 TM Modes.....	1-42
1.6.3 CW and PW Modes	1-43
1.6.4 CFM Formats.....	1-43
1.7 SIGMA 110 Technical Specifications.....	1-44
1.7.1 General.....	1-44
1.7.2 2D (B-Mode)	1-46
1.7.3 TM (M-Mode).....	1-46
1.7.4 Spectral Doppler Mode.....	1-47
1.7.5 Digital Archiving: KIPRISM	1-48
1.7.6 ECG Module (option)	1-48
1.7.7 EasyPrint™.....	1-49
1.7.8 USB-Link™	1-49
1.7.9 Peripherals (Optional).....	1-49
1.7.10 Inputs/Outputs	1-49
1.7.11 Measurement.....	1-49
1.7.12 Acoustic Power	1-51
1.7.13 Environment.....	1-51
1.7.14 Regulation and Safety	1-51

1.7.15	Dimensions	1-52
1.8	SIGMA 330 Technical Specifications	1-53
1.8.1	General	1-53
1.8.2	2D (B-Mode).....	1-55
1.8.3	TM (M-Mode)	1-56
1.8.4	Spectral Doppler Mode	1-56
1.8.5	Colour Doppler Modes	1-58
1.8.6	3D Imaging.....	1-58
1.8.7	Digital Archiving: KIPRISM.....	1-59
1.8.8	ECG Module (option)	1-59
1.8.9	EasyPrintTM.....	1-59
1.8.10	USB-LinkTM.....	1-59
1.8.11	Peripherals (Optional)	1-60
1.8.12	Inputs/Outputs.....	1-60
1.8.13	Measurement	1-60
1.8.14	Acoustic Power.....	1-61
1.8.15	Environment	1-62
1.8.16	Regulation and Safety	1-62
1.8.17	Dimensions	1-62
2.	INSTALLATION	2-1
2.1	Installation Requirements	2-3
2.2	Unpacking	2-3
2.2.1	Warning.....	2-3
2.2.2	Unpacking the Instrument	2-3
2.3	Checking the Instruments Identification	2-3
2.4	Checking the Delivery	2-4
2.5	Transport.....	2-6
2.6	Installation of SIGMA 330 Expert and SIGMA 330 Excellence.....	2-7
2.6.1	Installation of the integrated cart	2-7
2.6.2	Installation of the flat panel monitor	2-8
2.6.3	Installation of the integrated compact PC (SIGMA 330 Excellence only).....	2-8
2.7	Power Source Connection	2-10
2.7.1	Input Power Source	2-10
2.7.2	Output Power Source	2-11
2.8	Connecting a Probe	2-12
2.8.1	SIGMA 330 Expert and SIGMA 330 Excellence Probe Assignment.....	2-12
2.8.2	SIGMA 110 Light/Master and SIGMA 330 Master Probe Assignment.....	2-13
2.8.3	Probe Connection	2-13
2.9	Connection of Peripherals.....	2-15
2.9.1	Electrical safety with peripherals	2-15
2.9.2	Recommended Peripherals.....	2-17
2.9.3	Archiving on Personal Computer.....	2-17
2.9.4	Connection of B&W Video Printer	2-18
2.9.5	Connection of Colour Video Printer.....	2-19

2.9.6	Video Recorder (VCR).....	2-20
2.9.7	ECG Module	2-22
2.9.8	Colour Monitors	2-23
2.9.9	Black & White Monitor	2-25
2.9.10	Printer	2-26
2.9.11	Connection with medical grade isolators	2-32
2.9.12	Connection with S-Video Distributor	2-33

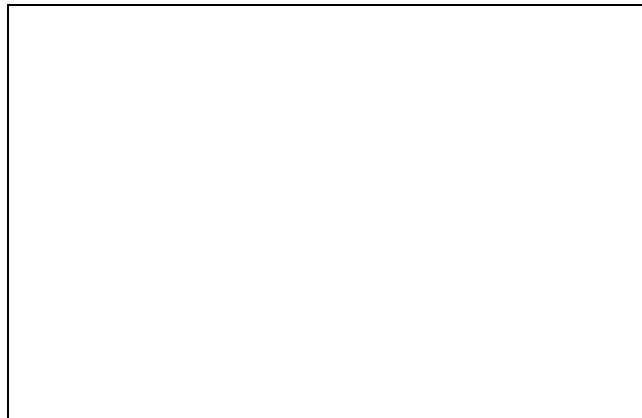
3.	OPERATING INSTRUCTIONS.....	3-1
3.1	Operating Precautions.....	3-3
3.2	Switching the Instrument ON.....	3-4
3.2.1	Switching ON SIGMA 110 and SIGMA 330 Master.....	3-4
3.2.2	Switching ON SIGMA 330 Expert.....	3-4
3.2.3	Switching SIGMA 330 Excellence ON	3-4
3.2.4	Initialization of SIGMA	3-5
3.3	Switching the Instrument OFF	3-6
3.3.1	Switching OFF SIGMA 110 and SIGMA 330	3-6
3.3.2	Switching OFF SIGMA 330 Excellence	3-6
3.4	Menus.....	3-7
3.4.1	Notes	3-7
3.4.2	Menu Key Conventions	3-7
3.4.3	Menu Types	3-7
3.4.4	Menu Display	3-7
3.4.5	Menu Items	3-8
3.5	Probes	3-11
3.5.1	Probe Selection	3-11
3.5.2	Menu Display	3-11
3.6	Setup	3-13
3.6.1	Setup Menu	3-13
3.6.2	Loading a Setup.....	3-13
3.6.3	Saving a Setup	3-13
3.6.4	Deleting a Setup	3-14
3.6.5	Preferences	3-14
3.6.6	PCMCIA CARD.....	3-23
3.6.7	System Info.....	3-23
3.7	Major Modes.....	3-25
3.7.1	2D Mode	3-25
3.7.2	TM (Time Motion)	3-31
3.7.3	PW Doppler	3-34
3.7.4	CW Doppler	3-39
3.7.5	CFM Mode	3-42
3.7.6	3D imaging.....	3-46
3.8	Print.....	3-47
3.9	Cine Mode	3-48
3.9.1	Storing Pictures	3-48

3.9.2	Displaying Pictures.....	3-49
3.9.3	Cine Auto-Replay	3-49
3.10	Magnifier in 2D and CFM Mode	3-50
3.11	Digital Archiving: KIPRISM	3-51
3.11.1	Image Storage and Freeze Menu.....	3-51
3.11.2	Archive: Display of Stored Images	3-52
3.11.3	Using the Memory Card on PC	3-54
3.11.4	Patient Report and Patient ID with KIPRISM	3-55
3.12	Annotations	3-59
3.12.1	Entering Annotation Mode.....	3-59
3.12.2	Exiting the Annotation Mode	3-59
3.12.3	Manual Text Annotation.....	3-60
3.12.4	Labels.....	3-60
3.12.5	Arrows	3-64
3.13	Body Markers.....	3-65
3.13.1	Displaying Body markers.....	3-65
3.13.2	Moving Body Markers.....	3-66
3.13.3	Deleting Body markers	3-66
3.13.4	Medical.....	3-66
3.13.5	Deleting All Annotations	3-66
3.14	Measurements	3-67
3.14.1	Generalities	3-67
3.14.2	Starting a Measurement.....	3-68
3.14.3	2D Measurement.....	3-68
3.14.4	CFM Measurement	3-75
3.14.5	TM Measurement	3-77
3.14.6	Doppler Measurement.....	3-82
3.15	Biometry and Report.....	3-90
3.15.1	Biometry Pictograms	3-90
3.15.2	Patient Information	3-90
3.15.3	Biometry Patient Study.....	3-90
3.15.4	Report	3-91
3.15.5	Starting a Study.....	3-91
3.15.6	Radiology Study	3-92
3.15.7	Obstetrics/Gynaecology Study	3-93
3.15.8	Vascular Study	3-94
3.15.9	Cardiology Study	3-94
3.16	ECG (Option)	3-95
3.17	EasyPrint™ Options.....	3-96
3.17.1	Printing of images	3-96
3.17.2	Printing of Report	3-98
3.18	USB-Link™ Option.....	3-99
3.18.1	Overview	3-99
3.18.2	Compatibility.....	3-99
3.18.3	Usage example with Windows® 2000.....	3-99
3.18.4	Read data from a computer	3-101

3.18.5	Copy data to the computer	3-101
3.18.6	Interface with PACS	3-102
3.18.7	Limitations.....	3-102
3.19	SonoWin® Lite and SonoWin® Basic PACS	3-103
3.19.1	Overview.....	3-103
3.19.2	Start a Study.....	3-104
3.19.3	Save images, reports and patient information	3-105
3.19.4	Transfer data to SonoWin®.....	3-106
3.19.5	Data Assignment	3-109
3.20	Integrated PC (SIGMA 330 Excellence)	3-110
3.20.1	Overview.....	3-110
3.20.2	SAFETY PRECAUTIONS	3-110
3.20.3	Entering PC remote control mode	3-111
3.20.4	PC remote control features description	3-111
3.20.5	Leaving PC remote control mode	3-111
3.20.6	Keyboard in PC mode.....	3-111
3.20.7	Errors and warnings.....	3-114
3.20.8	PC power on	3-114
3.20.9	PC power off	3-114
3.20.10	3D VascularView™ and 3D FetalView™	3-115
3.20.11	PACS option.....	3-115
3.20.12	Connection to a Network	3-115
3.20.13	Installation of peripherals.....	3-115
4.	MAINTENANCE	4-1
4.1	Cleaning	4-3
4.1.1	Probes	4-3
4.1.2	TV Monitor	4-3
4.1.3	EYE-Q 300M Monitor.....	4-3
4.1.4	Keyboard.....	4-3
4.1.5	Instrument.....	4-4
4.2	Disinfection	4-5
4.3	Repairs and Maintenance.....	4-8
4.3.1	User Maintenance.....	4-8
4.3.2	Manufacturer Maintenance	4-9
4.4	Product Recycling and Disposal.....	4-10
5.	TROUBLESHOOTING	5-1
5.1	Handle Error and Warning Messages	5-3
5.2	Introduction and Rules.....	5-4
5.2.1	Rules.....	5-4
5.2.2	Definition.....	5-4
5.2.3	Remarks	5-4
5.3	Status Messages	5-5

5.3.1	ECG	5-5
5.3.2	Measurement and Biometry	5-7
5.3.3	Transmit Voltage Indicator	5-8
5.4	Warnings	5-9
5.4.1	Start-up checks	5-9
5.4.2	System Configuration Check	5-10
5.4.3	Flash card and SRAM	5-11
5.4.4	Miscellaneous checks	5-13
5.5	General Failures and Errors	5-18
5.5.1	Error 0: Internal unexpected interrupt	5-18
5.5.2	Error 1: Can not restore backed up configuration	5-18
5.5.3	Error 2: Tracking problem - Fatal error	5-19
5.5.4	Error 3: Memory allocation error - Fatal error	5-19
5.5.5	Error 4: Divide by 0 - Fatal error	5-19
5.5.6	Error 5: Communication error	5-19
5.5.7	Error 6: Flash card read error	5-19
5.5.8	Error 7: Flash card write error	5-19
5.5.9	Error 8: Invalid flash card type	5-20
5.5.10	Error 9: Ob/Gyn restore error	5-20
5.5.11	Error 10: Flashcard not correctly formatted	5-20
5.5.12	Error 11: Internal Communication - Fatal error	5-20
5.5.13	Error 12: Cannot program TMPAVG	5-20
5.5.14	Error 13: CFM Frame Filter LUT Error	5-21
5.5.15	Error 14: CFM Function LUT Error	5-21
5.5.16	Error 15: CFM LUT programming time out error	5-21
5.5.17	Error 16: Flashcard removed while printing	5-21
5.5.18	Error 17: Internal communication - Fatal error	5-21
6.	OPTIONS AND ACCESSORIES	6-1
6.1	Options	6-3
6.2	List of Probes	6-4
6.3	Accessories	6-5
7.	APPENDICES	7-1
	Appendix A: Overview	7-3
A.1	Entering the Biometry	7-3
A.2	Exiting the Biometry	7-3
A.3	Make a Measurement from Report	7-3
A.4	Importing Measurements in Report	7-4
	Appendix B: Report Menu	7-5
	Appendix C: Patient Information	7-7
C.1	First Page	7-7
C.2	Second Page	7-9

Appendix D: Cardiology Study	7-11
D.1 Left Ventricle Study	7-12
D.2 Mitral Valve Study	7-18
D.3 Aortic Valve Study	7-22
D.4 Right Ventricle Study	7-26
Appendix E: Vascular Study	7-31
E.1 Description	7-31
E.2 Stenosis Percentage	7-31
E.3 Equations	7-33
Appendix F: Ob/Gyn Studies	7-37
F.1 2D Sheet	7-37
F.2 TM/SP Sheet	7-41
F.3 Foetal Information Sheet	7-43
F.4 Setup Sheet	7-44
F.5 User Table Sheet	7-47
F.6 Curve View	7-48
Appendix G: Reference Tables for Ob/Gyn	7-49
G.1 Biparietal Diameter (BPD)	7-49
G.2 Chorion Diameter (ChD) from Rempen	7-57
G.3 Femur Length (FML)	7-58
G.4 Humerus Length (HuL)	7-65
G.5 Transabdominal Diameter (TAD) from Merz	7-67
G.6 Thoracic Diameter (THD) from Hansmann	7-68
G.7 Anterior Posterior Diameter (APD)	7-69
G.8 Crown Rump Length (CRL)	7-71
G.9 Gestational Sac (GES)	7-76
G.10 Abdominal Circumference (AC)	7-78
G.11 Head Circumference (HC)	7-81
G.12 Binocular Distance (BOD) from Jeanty	7-84
G.13 Occipital Frontal Diameter (OFD) from Merz	7-84
Appendix H: Radiology Study	7-85
H.1 Description	7-85
H.2 Equations	7-86
Appendix I: Measurement Interface	7-89
I.1 Doing a Measurement from Report	7-89
I.2 Importing Measurements in Report	7-91
Appendix J: Print Preview	7-93
J.1 Edit the Printable Report	7-93

J.2	Print the Report on an External Printer	7-94
J.3	Save the Report on a Flashcard	7-94
Appendix K: KIPRISM / SonoWin® Basic Conversion Tables....		7-95
K.1	Overview	7-95
K.2	Cardiology Measurements	7-95
K.3	Vascular measurements	7-102
K.4	Obstetric and Gynaecology	7-104
K.5	Radiology Study	7-108
K.6	Multiple associations	7-109
Appendix L: Body Markers		7-111
L.1	Vascular	7-111
L.2	Radiology	7-111
L.3	Obstetrics/ Gynaecology	7-112
L.4	Cardiology	7-112
Appendix M: Acoustic Output Tables		7-113
M.1	Track3 Summary Tables	7-113
M.2	Definition of Terms	7-114
M.3	Acoustic Output Tables	7-116

III. Intended Clinical Use and Safety Information

This system complies with the Medical Device Directive (MDD) 93/42/EEC, according to which KONTRON MEDICAL has classified this device as a Class 1 Type B device.

Note for U.S. Customers

U.S Federal Law restricts this device to sale, distribution and use by or on the order of a physician.

III.1. Intended Clinical Use

The SIGMA 110 / 330 is intended for visualization by ultrasound of internal organs, for medical diagnostic purposes only. It must be operated by qualified and trained Physician or "Sonographer".

The particular organs visualized, and the methods of visualization, depend on the particular transducer used, and the imaging mode employed.

"Modes" are used in two senses in this manual: "Imaging Modes" refer to the method of depicting the organs visualized, and are explained below. It is also used to indicate various operational modes, such as "freeze," "zoom," "cine", etc. In general, it is obvious when a non-imaging mode is referred to. In the manual they are explained when they are first used.

The principal imaging modes of the SIGMA 110/330 and their abbreviations, which are used throughout this manual, are as follows:

2D: Two-dimensional representation of a "slice" in the body, often called "B-mode."

TM: Often called just "M-Mode," the ultrasound beam is stationary (giving an A-scan), but the time axis moves, with the result that moving organs can be easily visualized.

PW: Pulse Wave Doppler, which permits determining the velocity of blood or another organ in the interior of the body.

CW: Continuous Wave Doppler, which determines the velocity of flow or movement of all elements within the range of the probe.

CFM: Colour-flow mapping, which superimposes a map of the velocity of moving organs or blood on top of a 2D scan (B-scan) of the organs.

The SIGMA 110/330 does not permit "composite" modes (two modes produced at the same time). However, two modes can be made sequentially and then displayed next to each other on the same screen. If two modes are displayed together, this is called a "double-pad" mode. If only one is displayed, it is called a "single-pad" mode.

These are all real-time displays. However, an image can be “frozen” at a particular point in time to produce a static display so that it may be studied in more detail later.

Imaging modes are explained in more detail in Chapter 3.7, “Major Modes”, on page 3-25

The following table lists the SIGMA 110 / 330 probes and their intended clinical use:

PROBE TYPE	Nominal Frequency (MHz)	PROBE APPLICATIONS	MODES
Convex Linear Probes			
3.5 MHz CV	3.5	Abdominal, Ob/Gyn	2D/TM/PW/CFM
3.5 MHz MC	3.5	Cardiology, Transcranial Abdominal, Vascular/Angiology	2D/TM/PW/CFM
6.5 MHz MC	6.5	Pediatrics, Cardiology, Vascular/Angiology	2D/TM/PW/CFM
Linear Probes			
5.0 MHz LV	5	Abdominal, Obstetrics, Pediatrics, Perivascular	2D/TM/PW/CFM
7.5 MHz LV	7.5	Pediatrics, Perivascular, Small Parts	2D/TM/PW/CFM
7.5 MHz LVS	7.5	Pediatrics, Perivascular, Small Parts	2D/TM/PW/CFM
Endocavitarian Probes			
6.5 MHz EV	6.5	Ob/Gyn, Urology	2D/TM/PW
6.5 MHz MR	6.5	Endorectal multiplane for Urology	2D/TM/PW
6.5 MHz VMC	6.5	Ob/Gyn, Urology	2D/TM/PW/CFM
Annular Sector Probes			
3.5 MHz GP	3.5	Cardiology, Abdominal, Ob/Gyn	2D/TM/PW/CW
5.0 MHz GP	5.0	Abdominal, Ob/Gyn Cardiology, Pediatrics	2D/TM/PW/CW
7.5 MHz GP	7.5	Vascular, Small parts, Neonatology	2D/TM/PW/CW
14 MHz PV	14	Perivascular, Small Parts, Breast, Muskuloskeletal	2D/TM/PW
Pencil Probes			
PEN 2 MHz	2	Cardiovascular	PW/CW
PEN 4 MHz	4	Vascular	PW/CW
PEN 8 MHz	8	Vascular	PW/CW
TCD 2 MHz	2	Transcranial Doppler	PW

Table i: Probe applications

Details on the various applications are below.

Abdominal / Gynaecology / Urology Application

The probe applies ultrasound energy through the patient abdomen to obtain an image of the abdominal organs to detect abnormalities (imaging) and assess the blood velocity, flow and patency of abdominal vessels through the Doppler modalities.

Perivascular Application

The probe applies ultrasound energy through the neck or extremities of a patient to obtain an image of the carotid artery, or other peripheral vessels, that can be used to detect abnormalities or obstructions in the vessel. In Doppler modes, the probe applies ultrasound energy through the neck or extremities of a patient to assess the blood velocity, flow or lack of flow and patency of peripheral vessels.

Small Parts Application

The probe applies ultrasound energy through the skin to obtain an image or a Doppler flow visualization of small organs such as the thyroid (neck), testicles (scrotal sac) and breast.

Cardiology Application

The probe applies ultrasound energy through the chest wall to obtain an image of the heart for purpose of assessing cardiac abnormalities. In Doppler modes, the probe applies energy through the chest wall to determine the velocity and direction of blood in the heart and in the vessels.

Obstetrics / Fetal Application

The probe applies ultrasound energy through a pregnant woman's abdomen to obtain an image of the fetus to detect structural abnormalities or to visualize and measure anatomical and physiological parameters of the fetus for the purpose of assessing fetal growth. In Doppler modes, the probe applies energy through the patient abdomen to detect placental or fetal flow abnormalities.

Note

The user should always follow the **ALARA** (As Low As Reasonably Achievable) principle, but especially in Obstetrics / Fetal applications. Use the lowest amount of acoustic output power for the shortest duration of time to obtain the necessary clinical diagnostic information.

Neonatology Application

The probe applies ultrasound energy through the neonatal head fontanelles to visualize brain structures (imaging) or flow (Doppler) to detect structural or functional abnormalities.

WARNING: This system is not to be used for transorbital or any other ophthalmic applications.

Transcranial Doppler

The probe applies ultrasound energy through the adult patient skull to, visualize flow (Pulsed Wave Doppler) to detect functional abnormalities.

WARNING: This system is not to be used for transorbital or any other ophthalmic applications.

The main features of the probes are shown in the table below:

PROBE TYPE	Frequency Range (F _L to F _H in MHz)	Scanning		Focal Point (mm)	Resolution		Ceramics	
		Angle (degree)	Width (mm)		lateral (mm)	axial (mm)	d (mm)	L x W (mm)
Convex								
3.5 MHz CV	2 - 5	45 - 60	-	70	1.2	0.7	-	86.4 x 12
3.5 MHz MC	2 - 5	30 - 90	-	70	1.5	0.7	-	38.2 x 11
6.5 MHz MC	4 - 9	30 - 90	-	45	0.6	0.4	-	33.4 x 6.5
Linear								
5.0 MHz LV	3 - 7	-	63	50	1.0	0.5	-	86.4 x 11
7.5 MHz LV	4 - 10	-	50	20	0.6	0.3	-	59.4 x 4.5
7.5 MHz LVS	4 - 12	-	38	25	0.5	0.3	-	38.4 x 6.5
Endocavitarian								
6.5 MHz EV	4 - 9	90 - 140	-	25	0.7	0.4	9	-
6.5 MHz MR	4 - 9	90 - 110	-	25	0.7	0.4	8	-
6.5 MHz VMC	4 - 9	45 - 111	-	45	0.6	0.4	-	33.4 x 6.5
Annular Sector								
3.5 MHz GP	2 - 5	45 - 90	-	70	1.6	0.8	16	-
5.0 MHz GP	3 - 7	45 - 90	-	40	0.8	0.5	11.4	-
7.5 MHz GP	5 - 10	40 - 90	-	20	0.4	0.3	7	-
14 MHz PV	8 - 16	40	-	15	0.3	0.2	5.5	-
Pencil								
TCD 2 MHz	2	-	-	45	3	-	15	-
PEN 2 MHz	2	-	-	45	3	-	13	-
PEN 4 MHz	4	-	-	30	2	-	9	-
PEN 8 MHz	8	-	-	20	2	-	6	-

Table ii: Probe Features

III.2. Safety Information

In this manual a **WARNING** pertains to possible injury to a patient and/or the sonographer. A **CAUTION** describes the precaution which are necessary to protect the equipment.

Be sure that you understand and observe each of cautions and warnings.

III.2.1. Electrical Safety

As defined in EN60601-1 (IEC Standard 601-1, safety of Medical Electrical Equipment), this equipment is classified as Class I, type B (probes), while the ECG module has a Class CF degree of protection.

WARNINGS

- The system must be properly grounded to prevent shock hazards. Protection is provided by grounding the chassis with a three wire cable and plug; the system must also be powered through a properly grounded receptacle.
- Electrical shock hazard. Do not remove any panel. Refer servicing and internal adjustments to qualified KONTRON personnel only.
- For continued protection against risk of fire, replace fuses only with fuses of the same type and rating (see Chapter 2.7, “Power Source Connection”, on page 2-10).
- The equipment is not suitable for use in the presence of a flammable anaesthetic mixture with air, oxygen or nitrous oxide. Do not use the system in the presence of flammable anaesthetics. Explosion is a hazard under such conditions.
- The system not watertight and provides a class IP(X)0 degree of protection to liquids; do not expose the system to rain or moisture. Avoid placing liquid containers on the system.
- Remove probes and electrocardiography leads from patient contact before applying a high voltage defibrillation pulse.
- Like any other ultrasound equipment, the SIGMA 110/330 uses high frequency signals which could interfere with pacemakers. You should be aware of this small potential hazard and immediately turn off the unit if interference in the pacemaker operation is noted or suspected.
- If you drop or strike a probe, do not use it until a measurement of the electrical leakage current has demonstrated that a electrical safety has not been compromised. It is also necessary to insure that the probe has not been cracked or damaged so that it produces erroneous scans.
- Do not immerse the entire probe in liquids to clean it. The probe is not watertight and immersion may compromise the electrical safety features of the probe. Carefully follow the cleaning instructions in this manual.
- Take all appropriate precautions to avoid impact damage to the sensitive face of the probe.
- The use of products not approved by KONTRON MEDICAL such as oil, Methylene blue, ether or some disinfectants could cause permanent damage to the sensitive part of the transducer. Only the KONTRON MEDICAL supplied gel (KONTRON supply part number 100 250, ultrasonic gel) is recommended by KONTRON MEDICAL for coupling the transducer to the skin. The use of an agent other than the approved gel may adversely affect the quality of the images and produce substandard results.
- The cart available with the SIGMA 330 Expert and SIGMA 330 Excellence provides insulated plugs and connectors to manage optional hard copy devices (VCR, printers). Follow the instructions in this manual to install such a device. Wrong connections may compromise the electrical safety of the system.
- Never connect additional peripherals directly to wall outlets; use a medical grade isolating transformer which must comply with IEC 601-1 specifications. Wrong connections may compromise the electrical safety of the system.
KONTRON MEDICAL provides a medical grade isolating transformer and isolating accessories on request, see Chapter 6.3, “Accessories”, on page 6-5 for ordering.









- Never connect Network (RJ-45) directly to the system; use a medical grade network isolator which must comply with IEC 601-1 specifications. Wrong connections may compromise the electrical safety of the system.
KONTRON MEDICAL provides a medical grade isolator on request, see Chapter 6.3, “Accessories”, on page 6-5 for ordering.

CAUTIONS

- In order to prevent an overheating, ensure that the ventilation openings are not covered and keep the SIGMA 110/330 rear panel away from a vertical wall.
- To prevent further damage to your system and the accessories, power off the unit if it does not start up correctly.
- Never expose the probes to gas, heat or unauthorized liquid sterilization procedures (see probe cleaning instructions). These methods can permanently damage the probe.
- Do not connect or disconnect an active probe during live scanning; the system must be in freeze mode or turned off to connect or disconnect a probe.
- Carefully follow the Operator’s Manual instructions to clean or disinfect a probe.

Safety Symbols

The International Electrotechnical Commission (IEC) has defined a set of graphic symbols for use on medical electronic equipment. The following symbols are used on KONTRON MEDICAL’ systems:

	ON (Power)
	OFF (Power)
	AC line input
	Protective earth (ground)
	Equalization potential terminal
	Type CF isolated E.C.G input, defibrillator proof (IEC 601 - 1)
	Type B equipment (IEC 601 - 1)
	This symbol generally means "Attention". Please consult the equipment documentation carefully before using any function labelled with this symbol

III.2.2. Environmental Safety

Electro-Magnetic Compatibility

This system complies with the EN60601-1-2 (Electro-Magnetic Compatibility). It is a Class B device.

Ultrasound units are designed to receive radio frequency (RF) energy and are, therefore, susceptible to other RF sources. As an example, other medical devices, information technology products or TV/Radio transmitters may all cause interference with the ultrasound system.

In the presence of RF interference, the physician must evaluate the image degradation and its diagnostic impact.

- **Electrostatic discharge (ESD)**
An electrostatic discharge is a short transient current flow. It may happen if electrostatically charged people touches a part of ultrasound system. ESD may causes white or black dots in 2D or TM mode, coloured dots in CFM and can be heard or seen as dots in Doppler mode. The effects created by ESD are not at all correlated with the ultrasound information. Therefore, they may be well differentiated from the true ultrasound echo.
- **Burst**
Bursts are short transient pulses on the mains power line. They may cause white or black dots in 2D or TM mode, coloured dots in CFM and can be heard or seen as dots in Doppler mode. The effects created by bursts are not correlated with the ultrasound information. Therefore, they may be well distinguishable from the true ultrasound echo.
- **Immunity restriction**
Electromagnetic fields in the environment of the ultrasound system may cause white or black patterns in 2D or TM mode, coloured patterns in CFM and can be seen as horizontal lines in Doppler mode. Especially in the Doppler modes (CW and PW), some lack of immunity may be observed in a narrow frequency band of 20 kHz at the used frequency and its multiples. Typically, the transducer acts like the reception antenna and the effects are stronger when it is applied to patient. In any case, the effects are not correlated with the ultrasound information; therefore, they may be well distinguishable from the true ultrasound echo.

Electro-Surgical Units (ESUs)

Electro surgical units or other devices that introduce radio frequency electromagnetic fields or currents into the patient, may interfere with the ultrasound image. An electro surgical device in use during ultrasound imaging will greatly distort the 2D image and render Doppler modalities useless.

Information about Reusing/Recycling

In this system, the packing materials are reusable and recyclable; the unit casings (plastic) and most of the cart components (plastic) are also recyclable.

The SIGMA 110 and SIGMA 330 contains electronic boards, batteries and tubes. Before you dispose the system, these boards, batteries and tubes must be removed and discarded according to local regulations or recycled where facilities exist. Contact your local KONTRON MEDICAL company or agent for further informations.

For battery disposal contact your local waste disposal facility.

III.2.3. Biocompatibility and Infection Control

Items in contact with patient

The probe and electrode materials that are in contact with patients, comply with the European applicable requirements (EN10993). No negative reactions to these materials have been reported.

Note

KONTRON probes and electrodes do NOT contain Latex.

Infection Control

Since probes and electrodes are intended to be used on intact skin, the use of this system has a very limited probability of being able to propagate infections; basic procedures as described later in this manual are sufficient for infection control.

III.2.4. Ultrasound Safety

Introduction

KONTRON MEDICAL has adopted the more recent requirements and recommendations established by the USA Food and Drug Administration and by the American Institute for Ultrasound in Medicine. The SIGMA 110/330 therefore, equipped with the **Acoustic Output Display** feature to provide the user with real-time, on-line information on the actual power of the system.

The following sections describe the rationale of this methodology. KONTRON MEDICAL recommends the use of the **ALARA** principle (see below), which is extensively covered in this manual.

Additionally to this operator manual you get the AIUM manual "Medical Ultrasound Safety" which covers the following topics more in detail: Bioeffects and biophysics, prudent use and implementing ALARA. Read it carefully before using the SIGMA 110/330.

Clinical Safety

In the USA, in more than three decades of use, there has been no report of injury to patients or operators from medical ultrasound equipment.

American Institute for Ultrasound in Medicine (AIUM)

Statement on Clinical Safety: October 1982, Revised March 1993 and October 1993

Diagnostic ultrasound has been in use for over 25 years. Given its known benefits and recognized efficacy for medical diagnosis, including use during human pregnancy, the American Institute of Ultrasound in Medicine herein addresses the clinical safety of such use:

No confirmed biological effects on patients or instrument operators caused by exposure at intensities typical of present diagnostic ultrasound instruments have been reported.

Although the possibility exists that such biological effects may be identified in the future, current data indicate that the benefits to patients deriving from the prudent use of diagnostic ultrasound outweigh the risks, if any, that may be present.

The **ALARA (As Low As Reasonably Achievable)** principle is the guideline for prudent use; during an exam, the user should use for the shortest duration the least amount of acoustic output to obtain the necessary clinical information for diagnostic purposes.

Ultrasound Bioeffects

Although diagnostic ultrasound has an excellent history of safety, it has been known for a long time that ultrasound, at certain levels, can alter biological systems.

The AIUM Bioeffects Committee describes two fundamental mechanisms by which ultrasound may induce biological effects: non-thermal or mechanical mechanisms and thermal effects.

Non-thermal bioeffects, also, referred to as **mechanical bioeffects**, seem to be caused by the alternate expansion and contraction of tissue induced when ultrasound pressure waves pass through or near gas. The majority of these non-thermal interactions, also known as cavitation, deal with the generation, growth, vibration and possible collapse of micro bubbles within the tissue. The occurrence of cavitation depends on a number of factors, such as the ultrasonic pressure and frequency, the ultrasonic field (focused or unfocused, pulsed or continuous), the nature and state of the tissue and boundaries. Mechanical bioeffects are a threshold phenomenon, occurring only when a certain level of output is exceeded. However, the threshold level varies depending on the tissue. The potential for mechanical effects is thought to increase as peak rarefactional pressure increases, but decrease as the ultrasound frequency increases.

Although there have been no adverse mechanical bioeffects in humans from diagnostic ultrasound exposure, it is not possible to specify thresholds at which cavitation will occur in mammals.

Thermal Bioeffects are the rise in temperature of tissue when exposed to acoustic energy. The acoustic energy is absorbed by body tissue; absorption is the conversion of this energy into heat. If the rate of energy deposition in a particular region exceeds the ability to dissipate the heat, the local temperature will rise. The rise in temperature will depend on the amount of energy, the volume of exposure, and the thermal characteristics of the tissue.

On-Screen Real-Time Acoustic Output Display

Until recently, application-specific output limits established by the USA Food and Drug Administration (FDA) and the user's knowledge of equipment controls and patient body characteristics have been the means of minimizing exposure. Now, more information is available through a new feature, named the Acoustic Output Display. The Output Display provides users with information that can be specifically applied to ALARA. It eliminates some of the guess work and provides both an indication of what may actually be happening within the patient (i.e. the potential for bioeffects), and what occurs when system control settings are changed. This makes it possible for the user to get the best image possible while following the ALARA principle and thus to maximize the benefits/risks ratio.

The SIGMA 110/330 incorporates a real-time acoustic output display according to the AIUM/NEMA "Standard for Real-Time Display of Thermal and Mechanical Acoustic Output Indices on Diagnostic Ultrasound Equipment" publication, adopted in 1992 by both institutions. This Output Display Standard is intended to provide on-screen display of these two indices, which are related to ultrasound thermal and cavitation mechanisms, to assist the user in making informed risk (i.e. patient exposure) / benefit (diagnostically useful information) decisions. Considering the type of

exam, patient conditions and the case study level of difficulty, the system operator decides how much acoustic output to apply for obtaining diagnostically useful information for the patient; the thermal and mechanical indices real-time display is intended to provide information to the system operator throughout the examination so that exposure of the patient to ultrasound can be reasonably minimized while maximizing diagnostic information.

For systems with an Output Display, the FDA currently regulates only the maximum output. The SIGMA 110/330 has been designed to automatically default to the proper range of intensity levels for a particular application. However, within the SIGMA 110/330 limits, the user may override the application specific limits, if clinically required. The user is responsible for being aware of the output level that is being used. The SIGMA 110/330 real-time output display provides the user with relative information about the intensity level.

The Mechanical Index

The Mechanical Index (MI) is defined as the Peak Rarefactional Pressure in MPa (derated by a tissue attenuation coefficient of 0.3 dB/cm/MHz) divided by the square root of the probe central frequency in MHz.

With the MI, the user can keep the potential for mechanical bioeffects as low as reasonably achievable while obtaining diagnostically adequate images. The higher the index, the larger the potential. However, there is no level that indicates when Bioeffects is actually occurring: The Index is not intended to give an “alarm” but are an aid in implementing the ALARA principle.

The Thermal Index

The purpose of the Thermal Index (TI) is to keep the user aware of conditions that may lead to a temperature rise under certain defined assumptions. It is the ratio between the total acoustic power to the power required to raise tissue temperature by 1°C, estimated on Thermal Models.

There are currently three Thermal Indices (each based on a specific Thermal Model) used to estimate temperature rise whether at the surface, within the tissues, or at the point where the ultrasound is focusing on bone:

1. The Soft Tissue Thermal Index (**TIS**) provides information on temperature increase within soft homogeneous tissue.
2. The Cranial Bone Thermal Index (**TIC**) indicates temperature increase of bone at or near the surface, as may occur during a cranial exam.
3. The Bone Thermal Index (**TIB**) provides information on temperature increase of bone at or near the focus after the beam has passed through soft tissue.

As with the Mechanical Index, the Thermal Indices are relative indicator of temperature rise: a higher value represents a higher temperature rise; they indicate that the possibility for an increase in temperature exists and they provide a relative magnitude that can be used to implement ALARA.

The SIGMA 110/330 Acoustic Output Display

The SIGMA 110/330 displays the Acoustic Output Indices during live scanning to the right of the screen, together with the transmit power setting and other technical data. The following abbreviations are used:

Index	Abbreviation
Mechanical Index	MI
Soft Tissue Thermal Index	TIS
Cranial Bone Thermal Index	TIC
Bone Thermal Index	TIB

The Output Display is organized to provide meaningful information to implement ALARA without “distracting” the user with unnecessary data. Each time a user selects a new probe a choice of applications is provided (Radio, Vasc., Ob/Gyn, Cardio); depending on the selection, the system will default the appropriate indices.

Note

Index values below 0.4 are displayed by this system as <0.4. Indices are displayed in 0.2 increments

To optimize ALARA, index values equal or higher than 0.4 are displayed even if the maximal index value does not exceed 1.0.

The SIGMA 110/330 does not provide combination modes (i.e. modes used simultaneously, such as real-time 2D and Doppler), but can display a tracing (Doppler or TM-Mode) with a reference 2D (frozen or periodically updated). The index for the active mode is indicated.

The SIGMA 110/330 Output Default Settings

System default settings depend upon the probe, the mode of operation and the application which is selected after selecting a probe. The SIGMA 110/330 defaults the transmit power to obtain output levels that are below the historic I_{spta} limits established by the FDA for the selected application.

Methodology and Accuracy of Display

The displayed indices values must be interpreted as relative information to help the user to achieve the ALARA principle.

Initial data are derived from laboratory measurements based on the AIUM standard. Then the indices are calculated beginning from these measurements according to the AIUM/NEMA “Standard for Real-Time Display of Thermal and Mechanical Acoustic Output Indices on Diagnostic Ultrasound Equipment” publication. Many of the assumptions used for measurements and calculation are conservative in nature. The measured water tank values are derated using the conservative attenuation coefficient established by the FDA (0.3 dB/cm/MHz). Over-estimation of actual In-Situ exposures is thus part of the calculation process.

A number of factors influence the estimation of the accuracy of the displayed indices, the most significant ones being the variability between probes and the laboratory measurements accuracy

(hydro phone, operator, algorithms, etc.) itself, while variability of the system pulser and efficiency is a minor contributor.

The accuracy of the measurement of the centre frequency is estimated to be $\pm 2\%$, of the acoustic pressure to be $\pm 16\%$, of the acoustic power to be $\pm 10\%$ and of the acoustic intensity to be $\pm 32\%$.

The accuracy estimate, based on the variability range of probes and systems, and on the inherent modelling and the above mentioned measurements errors, ranges from $\pm 30\%$ for the MI index to $\pm 50\%$ for the TI index.

The SIGMA 110/330 Maximum Acoustic Output

As per the AIUM standard, the tables in Appendix M: Acoustic Output Tables list the maximum TI (Thermal Index) and MI (Mechanical Index) values for each probe and mode of operation.

The system screens display the recently adopted MI, which is now considered a better relative indicator of non-thermal bioeffect mechanisms. The SIGMA 110/330 maximal MI is 1.9 which FDA has recognized as equivalent to pre-amendments Isppa limits.

The SIGMA 110/330 maximum output for Ispta is limited to the preamendments FDA limit for peripheral vascular applications, which is 720 mW/cm^2 .

The maximum output for a given probe can be less than the system limit, since the maximum depends on a variety of elements (crystal efficiency, mode of operation etc.). It is normally reached with the Vasc. setup, at minimum depth or maximum PRF and in CFM with the smallest CFM window size.

All terms are defined in Section III.2.6, "Glossary and definition of terms," on page xxviii

The SIGMA 110/330 Acoustic Output Controls

Control features may be divided into three categories:

1. controls which directly affect the intensity (**direct** controls)
2. controls which indirectly affect the intensity (**indirect** controls)
3. controls which do not affect the intensity, such as the gains and the processing curves.

Controls which directly affect the intensity:

- the Application selection, which establishes the appropriate range of intensities (see Maximum Output Section)
- the Energy control for Doppler modes, which allows to increase or decrease the output intensity within the range of the selected application.

Controls which indirectly affect the intensity:

This category includes controls which change several aspects of the transmitted ultrasonic field rather than the intensity. Intensity is affected because of the field variations. Each mode has its

own pulse repetition frequency (PRF) and intensity level; moreover, for each mode, a number of parameters will indirectly affect the transmitted field.

2D

The SIGMA 110/330 allows the user to set the transmit focal point which will affect the indices by varying the beam profile. Generally, higher MI's will occur with farer focal points. If more than one transmit focal point is activated, MI values will correspond to the zone with the largest value.

TM

In TM mode, the transmitted field is only affected by the transmit focal point and the frequency. If M-Mode is displayed with a 2D and the 2D is updated, the system may shows always the index for the active mode (MI for 2D, TI for TM mode)

CFM

The TI may be increased by any control which increases the system frame rate:

- reducing the CFM window size
- increasing the CFM PRF

Another variable factor is the CFM frequency; the outcome in terms of transmitted field is marginal and largely unpredictable.

Pulsed Wave Doppler

In PW, the transmit energy is adjusted automatically when changing gatesize or PRF to be constant. Therefore the TI is constant for all settings of gatesize and PRF. The only "variable" factor is the Doppler frequency; the outcome in terms of transmitted field is marginal and largely unpredictable.

Continuous Wave Doppler

In CW, the only "variable" factor is the Doppler frequency. Most probes provide Doppler at more than one frequency; the outcome in terms of transmitted field is marginal and largely unpredictable. The user can vary the spectral velocity range; this does NOT, however, change the system's PRF.

Implementing ALARA with the SIGMA 110/330

Prudent use implies that during an exam the user should use for the shortest time the least amount of acoustic output to obtain the necessary clinical information for diagnostic purposes. In other words, your goal is to keep the TI and the MI indices as low as possible for the shortest time while obtaining the necessary clinical information.

This section does not cover the patient and technique factors which may influence the indices such as the patient body size, the tissue perfusion characteristics, the presence or the absence of fluid, etc.

- select the appropriate application when you select the probe

- depending on the patient characteristics and the type of exam (see Intended Use Section) select the appropriate probe and frequency
- use the system capabilities to preset the SIGMA 110/330 to default each mode according to your needs or specific applications; this will reduce the need for real-time interactions and help you obtain useful images quickly thus reducing ultrasound exposure
- start scanning with a low output level and optimize the focusing, the gains and all other system adjustments; if this is not adequate for diagnostic purposes, then increase the output level
- use the Output Display feature to guide your settings; remember that the indices do not consider TIME exposure: the higher your indices, the shorter should be the patient exposure

Which index when

In cardiology, vascular and general purpose (abdominal, small parts) exams **MI** is the primary concern in 2D mode, while **TIS** is the principle index in CFM and Doppler.

In Ob/Gyn the **TIB** should be considered when scanning a second or third trimester fetus, while the **TIS** is more reliable for earlier exams.

The **TIB** is a better predictor during neonatal head studies, while the **TIC** is more significant in adult transcranial studies.

III.2.5. Measurement Accuracy on SIGMA 110/330

This is thoroughly discussed in Chapter 1.7.11 on page 1-49 and Chapter 1.8.13 on page 1-60.

III.2.6. Glossary and definition of terms

In Situ Intensities calculations

When determining the possible effects of the ultrasound beam on tissue, the intensity encountered at the tissue site must be calculated. Because of attenuation of the beam within the body, the intensity at the tissue site (“in situ”) may be 10 to 100 times less than if it was measured at the same location in water. The amount of attenuation from experience by an ultrasound beam as it travels through the body tissue is determined by three factors:

1. Type of tissue along the beam path
2. Frequency of the ultrasound energy
3. Distance covered by the beam

In order to achieve a conservative approximation of attenuation due to these three factors, the FDA requires the application of the following formula:

$$I_d = I_w \exp (-0.23 a f z)$$

- I_d is the estimated “In Situ” intensity at the tissue site
- I_w is the intensity measured in water at the distance “z”, measured in cm
- a is the attenuation coefficient expressed in dB/cm/MHz
- f is equal to the acoustic frequency in MHz of the ultrasound beam

Definition of terms

The Acoustic Intensity generated by an ultrasound probe is usually described as follows:

Ispta

The Spatial Peak Time Average Intensity is an ultrasound intensity averaged over time at the point in the acoustic field where the pulse average intensity is at maximum.

Isppa

The Spatial Peak Pulse Average Intensity is an ultrasound intensity averaged over the pulse transmission time at a point in the acoustic field where the pulse average intensity is at maximum.

Imax

The Maximum Intensity is an average intensity during the half-cycle with the greatest amplitude during the pulse.

Mechanical Index MI

The Mechanical Index is defined as the peak rarefactional pressure in MPa (derated by a tissue attenuation coefficient of 0.3 dB/cm/MHz) divided by the square root of the probe central frequency in MHz.

Thermal Index TI

The Thermal Index is the ratio between the acoustic power and the power required to raise tissue temperature by 1°C, estimated on Thermal Models.

Peak rarefactional pressure

The Peak rarefactional pressure (p_r in MPa) is temporal peak rarefactional pressure amplitude at a specified point.

Pulse Intensity Integral

The Pulse Intensity Integral (PII) is time integral of instantaneous velocity for any specific point and for any specific pulse, integrated over the time in which the envelope of acoustic pressure or the envelope of hydrophone signal for the specific pulse is non-zero. It is equal to the energy fluence per pulse.

IV. Compliance with Standards

SIGMA 110 and SIGMA 330 systems manufactured by KONTRON MEDICAL, entirely comply with the Council Directive 93/42/EEC of 14 June 1993 concerning medical devices, and bear the CE Mark.

They are in compliance with

- CE MDD mark
- German K.V. regulation
- IEC 601-1 Class 1 Type B (Electrical Safety)
- IEC 1157 (Acoustic power reporting)
- FDA 510 (k)

Consequently, all OEM equipment (video recorders, external TV monitors and other peripherals) should be:

- connected to the three isolated outputs provided by SIGMA 330 Expert or Excellence cart or to wall outlets using the proper isolator (see Chapter 6.3, “Accessories”, on page 6-5 for ordering).
- marked with CE identification mark and be in compliance with IEC 950 or IEC 601-1 Standards.

1. INSTRUMENT DESCRIPTION

1.1 Introduction

SIGMA 110 and SIGMA 330 are Ultrasound Diagnostic Systems intended for scanning in multi-application. They both support 2D, TM and spectral Doppler ultrasound modes. SIGMA 330 additionally supports Colour Flow Mapping (CFM).

SIGMA 110/330 can be used in following applications:

- Abdominal
- Breast
- Cardiology
- Emergency
- Endocrinology
- Gastro-enterology
- Gynaecology
- Musculoskeletal
- Neonatology
- Obstetrics
- Paediatrics
- Small parts
- Urology
- Vascular

SIGMA 330 features some unique characteristics in its category:

- Dual Optimization Technique (D.O.T.)
- Auto-adaptive Frequency Adjustment (A.F.A.TM)
- Advanced Tissue Echo Cancellation (A.T.E.C.TM)
- EasyPrintTM (Option)
- USB-LinkTM (Option)
- PW/CW spectral Doppler (Option)
- CFM (Option)
- Multi-frequency and Multi-technology Transducers (M.M.T.)
- Up to 5 transducers simultaneously connected
- Super High Frequency Transducer (S.H.F.T.)
- Iris colour system for optimal rendering of echo structures
- 256 levels grey scale
- Up to 282 images cine-loop
- KIPRISM, digital storage
- Ergonomic design for optimal user comfort
- Remote Control

The SIGMA 110 Family features some unique characteristics in its category:

- Dual Optimization Technique (D.O.T)
- Auto-Adaptive Frequency Adjustment (A.F.A.[™])
- Advanced Tissue Echo Cancellation (A.T.E.C.[™])
- EasyPrint[™] (Option)
- USB-Link[™] (Option)
- Multi-frequency and Multi-technology Transducers (M.M.T.)
- Up to 5 transducers simultaneously connected
- Super High Frequency Transducer (S.H.F.T.)
- 256 levels grey scale
- Ergonomic design for optimal user comfort (E.D.O.)
- PW/CW spectral Doppler (Option)
- Up to 282 images cine-loop (Option)
- KIPRISM, digital storage
- Remote Control (Option)

1.2 SIGMA 110/330 Equipments

The table below shows the composition of the SIGMA 110/SIGMA 330 family.

Name	Relationship
SIGMA 110 Light	SIGMA 110 accepting Annular Sector probes only
SIGMA 110 Master	SIGMA 110 accepting Annular Sector probes and Linear/ Convex probes
SIGMA 330 Master	SIGMA 330 including colour monitor and Iris features
SIGMA 330 Expert	SIGMA 330 Master with integrated cart and dual port for Linear/ Convex probes
SIGMA 330 Excellence without Frame Grabber	SIGMA 330 Expert with Colour Doppler (CFM) and extended capabilities (Picture Archiving and Communication System, etc.)
SIGMA 330 Excellence with Frame Grabber	SIGMA 330 Expert with Colour Doppler (CFM) and extended capabilities (3D, Picture Archiving and Communication System, etc.)

Table 1-1: SIGMA 110/330 family

The SIGMA 110/330 systems are available in different language versions.

The following table lists the ordering reference numbers of the SIGMA 110/SIGMA 330 models.

Models	References					
	English	French	German	Italian	Spanish	Cyrillic
SIGMA 110 Light	480 770	483 788	483 966	484 121	484 318	484 482
SIGMA 110 Master	482 110	485 012	485 195	485 365	485 543	485 713
SIGMA 330 Master	482 080	485 209	485 373	485 551	485 721	485 918
SIGMA 330 Expert	482 420	483 818	483 982	484 156	484 334	484 504
SIGMA 330 Excellence without frame grabber board	483680EN	483680FR	483680GE	483680IT	483680SP	483680CY
SIGMA 330 Excellence with frame grabber board	483400EN	483400FR	483400GE	483400IT	483400SP	483400CY

Table 1-2: Reference numbers of SIGMA 110/SIGMA 330

The following table summarizes the configurations of the SIGMA 110/SIGMA 330 models:

PRODUCT	SIGMA 110		SIGMA 330				
	Light	Master	Master	Expert	Excellence		
					w/o FG	with FG	
Start-up label (SIGMA ...) ^a	110 Light	110	330	330	330	330	
CONFIGURATION	Integrated Cart			✓	✓	✓	
	Bolero Cart	Option	Option	Option			
	Probes holder set	✓	✓	✓			
	Handle	Option	Option	Option			
	Colour monitor, Iris features ^b			✓	✓	✓	✓
	Linear/Convex probes		✓	✓	✓	✓	✓
	Spectral Doppler ^c	Option	Option				
	CFM+ Power+ Spectral Doppler			Option	Option	✓	✓
	Cine	Option	Option	✓	✓	✓	✓
	ECG	Option	Option	Option	Option	Option	
	Remote Control	Option	Option	✓	✓	✓	✓
	Footswitch	Option	Option	Option	✓	✓	✓
	Switchbox		Option (external)	Option (external)	✓	✓	✓
	Repetition Monitor	Option	Option	Option	Option		
	PCMCIA Memory Card	Flash	Flash	SRAM 4MB	SRAM 4MB	SRAM 4MB	SRAM 4MB
	VHS option	Option	Option	Option	Option	Option	Option
	Time Renting	Option	Option	Option	Option	Option	Option
	EasyPrint™ Black & White ^d	Option	Option				
	EasyPrint™ Color			Option	Option	✓	✓
	USB-Link™	Option	Option	Option	Option	✓	✓
	Integrated compact PC and Flat 15" LCD Monitor for PC					✓	✓
3D-Fetal View™ option						Option	
3D-Vascular View™ option						Option	
PACS ^e SonoWinlite® option	Option	Option	Option	Option	Option	Option	
PACS ^e SonoWinbasic® option	Option	Option	Option	Option	Option	Option	
KIPRISM ^f	✓	✓	✓	✓	✓	✓	
Cardiology features ^g	✓	✓	✓	✓	✓	✓	

Table 1-3: System configuration and options

- a. Label displayed in the start-up or system information screens.
- b. Iris features include colour gamma curves (Rainbow) and colorised screen layout (measurement, technical data, etc.).
- c. Spectral-Doppler option includes PW, CW, Cine review, Angio package and VMean / VMax traces.
- d. Requires Cine option.
- e. Picture Archiving and Communication Systems. Please contact your local dealer for more information.
- f. The complete features of Digital Archiving are obtained with Cine option. Without Cine only the Store feature is available.
- g. Cardiology includes cardiology formats and setups, biometry and measurements, ECG display that requires ECG module.

1.3 Physical Description

The **basic SIGMA 110/330** is a transportable Ultrasound unit which includes the following sub-assemblies:

- Electronic cabinet containing all electronic modules
- Keyboard panel
- Black and White or colour video monitor
- Stereo audio system for Doppler
- Video Cassette Recorder output
- Black & White and colour Printer output

The **SIGMA 110 Light**, **SIGMA 110 Master** and **the SIGMA 330 Master** consist of the basic SIGMA 110/330 and a transducer holder kit for two transducers and for a bottle of ultrasonic gel.

A front view of these versions and the front panel opened showing the keyboard and screen are shown in figure 1-1, "SIGMA 110 Light, Master and SIGMA 330 Master", on page 1-8.

The **SIGMA 330 Expert** consists of the basic SIGMA 110/330 system combined with an integrated cart which provides:

- Room for optional Video Cassette Recorder
- Room for optional Printers
- Room for accessories
- Elevating column for user-adaptative height

The pedal on the base of the instrument is used to control the desired position: press the pedal to lift up; while keeping the pedal depressed, push down the column top part to get it down.

In addition to the SIGMA 330 Expert features, the **SIGMA 330 Excellence** includes a flat screen associated with an integrated personal computer for 3D imaging and patient data management.



Figure 1-1: SIGMA 110 Light, Master and SIGMA 330 Master



Figure 1-2: SIGMA 330 Expert



Figure 1-3: SIGMA 330 Excellence

1.3.1 Electronic Cabinet

The electronic cabinet includes the required circuitry to perform complete functions.

- Power Supply
- Processor which controls the main system functions and the user interface.
- Transmitter/receiver modules for both linear/convex and sector transducers.
- Scan Converter
- Digital processing and filtering
- Spectral-Doppler
- Colour Flow Mapping

1.3.2 Control Panel

The Control Panel is connected to the main electronic board through a serial line. Its ergonomics allows the user to communicate easily with the system.

The keyboard includes a backlight that allows the system to be used in semi-darkness.

The Control Panel includes:

- 23 function keys
- 10 menu function keys. Their current functions are displayed on the corresponding MENU on the screen.
- 1 incremental potentiometer (softpot). Its current function is displayed in the corresponding MENU on the screen.
- 1 potentiometer for 2D or TM gain adjustment.
- 1 potentiometer for spectral gain adjustment in CFM, PW and CW.
- 1 potentiometer for depth selection.
- 5 sliders (rectilinear potentiometers) for gain equalization.
- 1 alphanumeric keyboard with standard upper case characters and useful graphic characters.
- 1 trackball with corresponding function keys.
- 1 Power ON/OFF button
- 1 Remote control

1.3.2.1 Keyboard

The controls located on the keyboard are listed below and shown in figure 1-4, "Keyboard", on page 1-13.

1. Remote control unit location
2. Power ON/OFF key
3. Potentiometer joined to function menus
4. Alphanumerical keys
5. MENU key
6. Menu function keys joined to menus displayed on screen
7. MENU PREVIOUS/NEXT keys
8. Time Gain Compensation (TGC)
9. Function keys
10. 2D/TM gain
11. CFM/PW/CW gain
12. Depth
13. FREEZE key
14. Validation (SET) keys joined to the trackball, 3 independent keys
15. Trackball

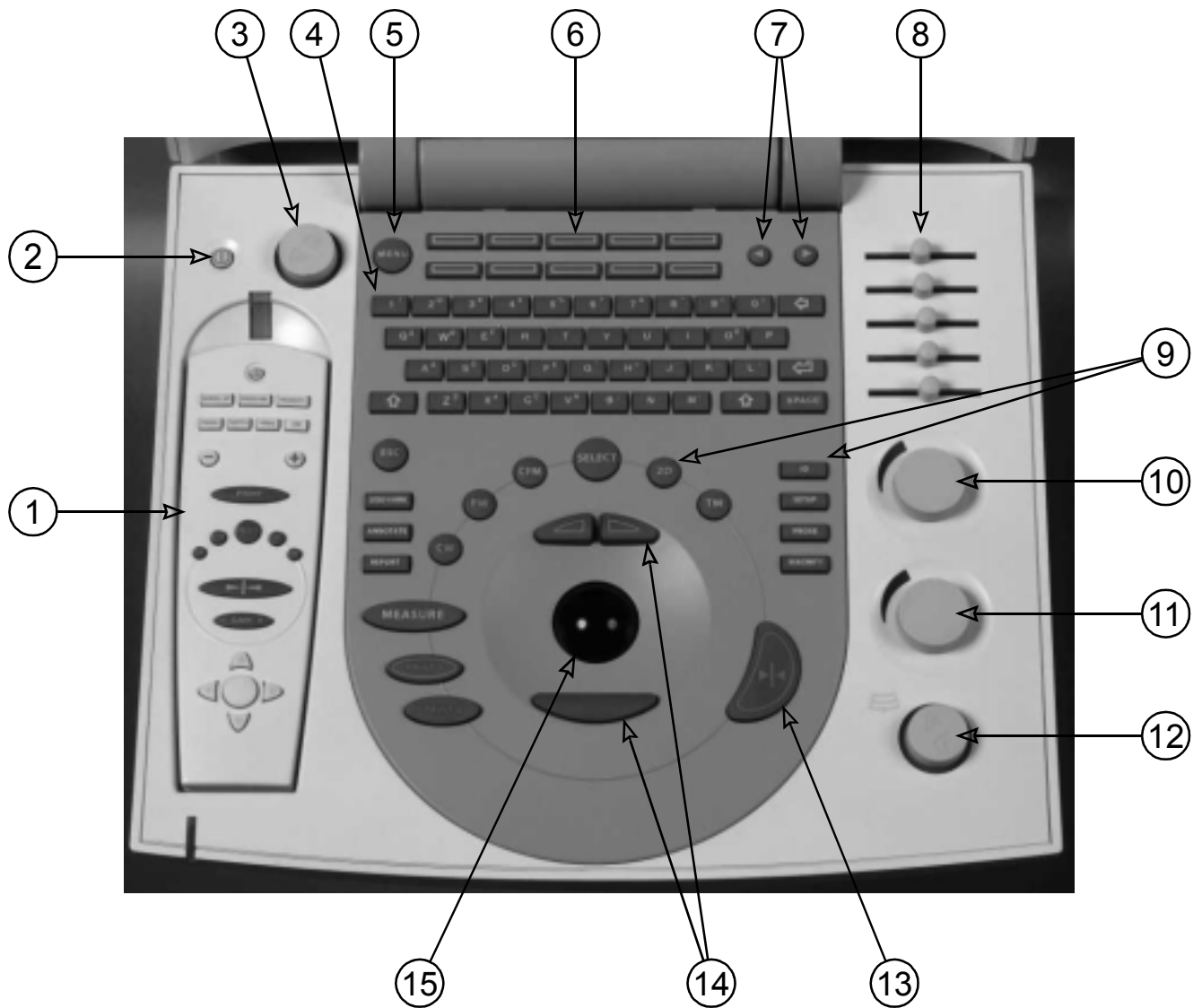

Figure 1-4: Keyboard

1.3.2.2 Remote Control Unit

It allows the remote control for main scanning parameters, freeze and image printing.

The main advantages of the remote control are:

- System control in any inadequate examination condition.
- Usage in operating room, because it can be easily disinfected.
- Operation in difficult environment.
- Group demonstration or lesson.

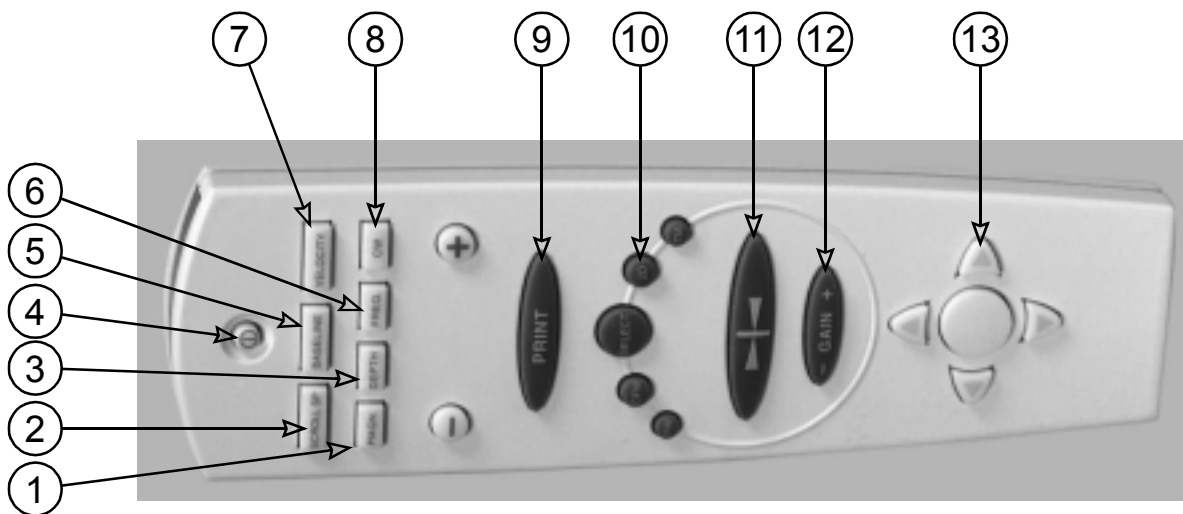

Figure 1-5: Remote Control Unit

The different keys available on the remote controller are the following:

- | | |
|----------------------|--|
| 1. MAGNIFY: | Magnify the ultrasound image by a factor 2 |
| 2. SCROLL SP (+/-): | Scrolling in Trace Modes |
| 3. DEPTH (+/-): | Depth change |
| 4. ON/OFF: | Power ON/OFF |
| 5. BASELINE (+/-): | Baseline shift in PW/CW and CFM mode |
| 6. FREQ (+/-): | Freq +/- in 2D, frequencies in PW/CW and CFM |
| 7. VELOCITY (+/-): | Velocity in PW/CW and CFM modes |
| 8. CW: | CW mode switch |
| 9. PRINT: | Equivalent to PRINT1 on the keyboard |
| 10. 2D, CFM, PW, TM: | Mode switch |
| 11. FREEZE key | |
| 12. GAIN (+/-): | 2D gain in 2D, SP gain in Doppler, CFM gain in CFM |
| 13. Trackball keys | |

The 3 keys **SCROLL SP**, **BASELINE** and **VELOCITY**, access directly to the corresponding Doppler parameters described in Chapter 3.7.3.2, "PW Live Menu", on page 3-36. For changing the selected parameter, use (-) and (+) keys.

For example, to modify the scroll speed:

1. Press **SCROLL SP** key to select the parameter.
2. Press (-) key to decrease the scroll speed or press (+) key to increase it.

The **DEPTH** key accesses directly to the corresponding 2D parameter described in Chapter 3.7.1.2, “2D Live Menu”, on page 3-28. For changing the parameter, proceed as described above.

MAGN. and **FREQ** are toggle keys described in Chapter 3.7.1.2, “2D Live Menu”, on page 3-28.

In PW/CW mode **FREQ.** corresponds directly to the frequency item displayed in the Doppler Menu on screen described in Chapter 3.7.3.2, “PW Live Menu”, on page 3-36 and Chapter 3.7.4.2, “CW Live Menu”, on page 3-41

The **(-GAIN+)** key modifies the overall gain according to the active mode. Press the left side of the key to decrease the gain or press the right side to increase it.

The trackball function of the control panel is replaced by 4 arrows and a button located in the centre. Use the arrows for moving in the four directions and press the button for validating the operation.

The keys **PRINT, TM, 2D, SELECT, CFM, PW, CW** and **FREEZE**, access directly to the corresponding functions described in *Chapter 1.4, System Controls* on page 1-28.

The Remote Control Unit is powered by two 1.5 V batteries (see Chapter 6.3, “Accessories”, on page 6-5 for ordering).

1.3.3 TV Monitor

1.3.3.1 General

SIGMA 110 units are equipped with a high quality 10" Black & White monitor to display images and information.

SIGMA 330 units are equipped with a high quality 10" colour monitor to display images and information.

The monitor is integrated into the instrument housing.

1.3.3.2 Controls

If the image is not satisfactory, check whether all controls are in the correct position for an optimum adjustment. The location of the controls is described in figure 1-6, “SIGMA 110 Light, SIGMA 110 Master and SIGMA 330 Master front view”, on page 1-17.

This page is intentionally left blank

1.3.4 Front Panel

1.3.4.1 SIGMA 110 Light, Master and SIGMA 330 Master Front View

The following items are shown in figure 1-6, "SIGMA 110 Light, SIGMA 110 Master and SIGMA 330 Master front view", on page 1-17:

1. Audio volume adjustment
2. Brightness adjustment for video screen
3. Contrast adjustment for video screen
4. Loudspeakers
5. Remote control receiver
6. Location dedicated to Remote Control Unit (Remote Control Unit is optional with SIGMA 110)
7. Video screen
8. Receptacle for bottle of gel
9. Probe holder
10. Keyboard

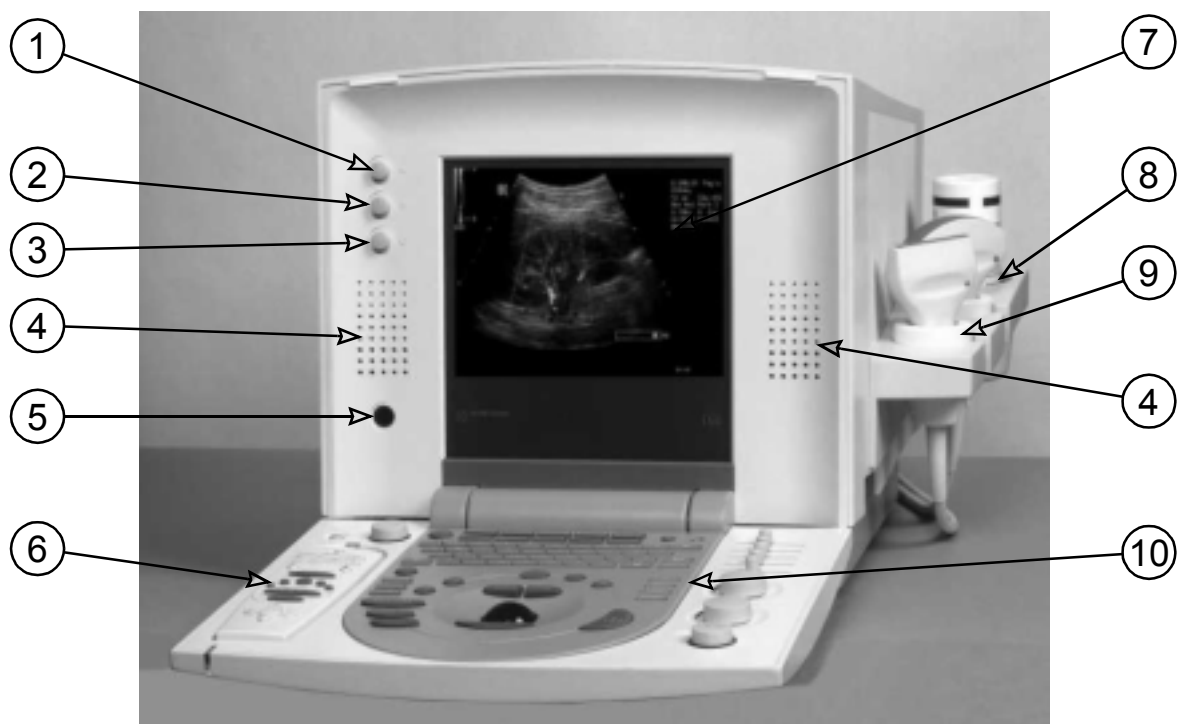

Figure 1-6: SIGMA 110 Light, SIGMA 110 Master and SIGMA 330 Master front view

1.3.4.2 SIGMA 330 Expert Front View

The following items are shown in figure 1-8, "SIGMA 330 Expert front view", on page 1-19:

1. Audio volume adjustment
2. Brightness adjustment for video screen
3. Contrast adjustment for video screen
4. Loudspeakers
5. Remote control receiver
6. Remote Control Unit
7. Keyboard
8. Cabinet for optional Video Printer
9. Cabinet for optional Video Cassette Recorder
10. Cabinet for accessories
11. Control pedal for carrying up/down the column
12. Video screen (colour monitor)



Figure 1-7: SIGMA 330 Expert front view (closed)

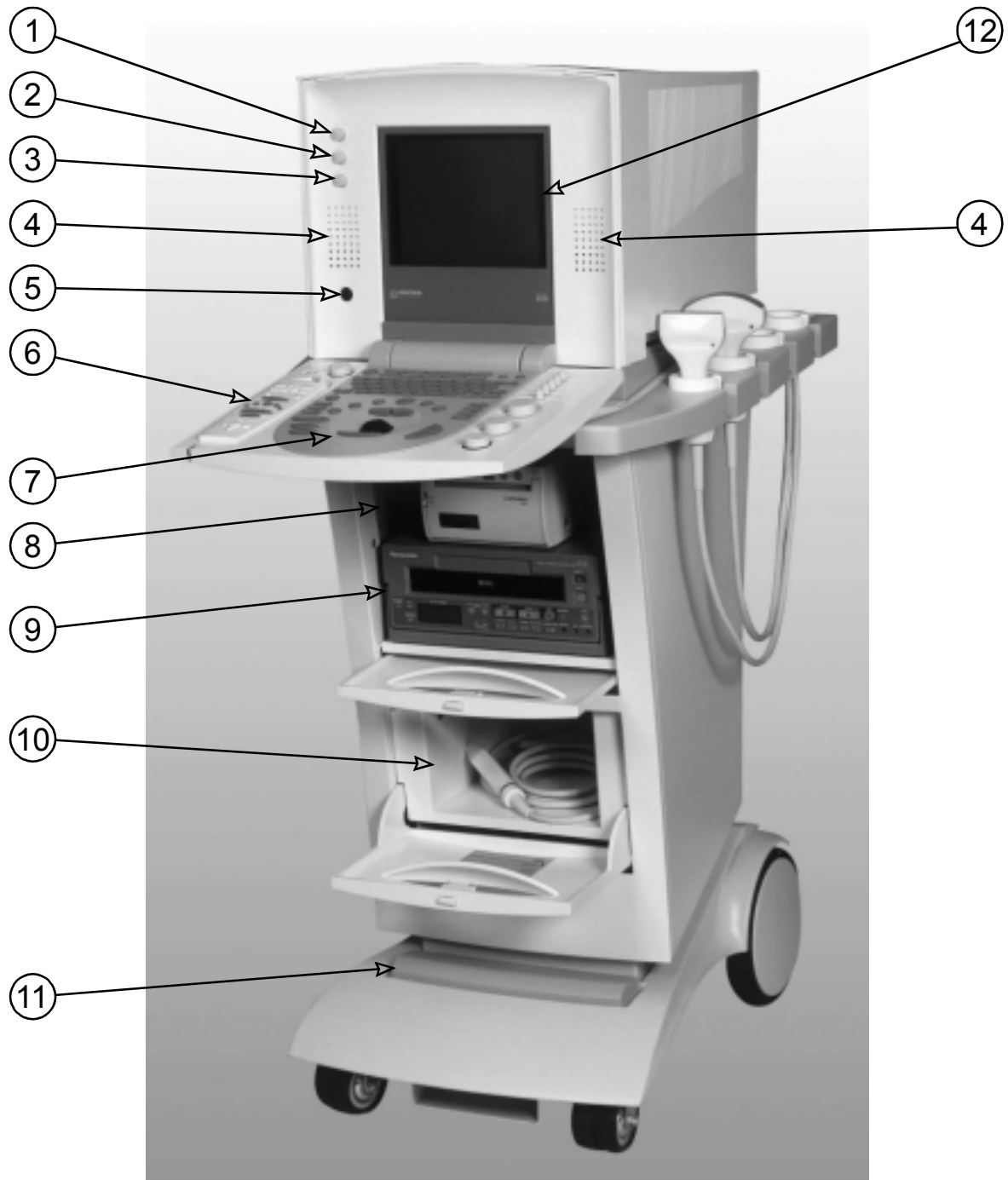

Figure 1-8: SIGMA 330 Expert front view

1.3.4.3 SIGMA 330 Excellence Front View

The following items are shown in figure 1-9, "SIGMA 330 Excellence front view", on page 1-21:

1. Additional high resolution flat screen
2. Compact personal computer integrated in the lower cabinet



Figure 1-9: SIGMA 330 Excellence front view

1.3.5 Rear Panel

1.3.5.1 SIGMA 330 Expert Rear Panel

1. Fuses (Electronic cabinet - top part)
2. Switch ON/OFF (Electronic cabinet - top part)
3. Mains plug (Electronic cabinet - top part)
4. Equalization potential terminal (Chassis Ground)
5. Probe holder
6. Guide for probe cable
7. Handle
8. Connectors for Linear/Curved Probes
9. Fuses (SIGMA 110/330 cart - bottom part)
10. Switch ON/OFF (SIGMA 110/330 cart - bottom part)
11. Mains plug (SIGMA 110/330 cart - bottom part)
12. Equalization potential terminal (Chassis Ground)
13. Equalization potential terminal (Chassis Ground)
14. Connector panel
15. Connector for Doppler Pencil Probes
16. Receptacle for bottle of gel
17. Connectors for Annular Sector Probes
18. Air filter grid
19. Identification labels:
 - at the top: (CE mark, model, reference, serial number, revision number)
 - at the bottom: (model, reference, serial number)

Output power: 3 outlets for peripherals (see Chapter 2.7.2, “Output Power Source”, on page 2-11)

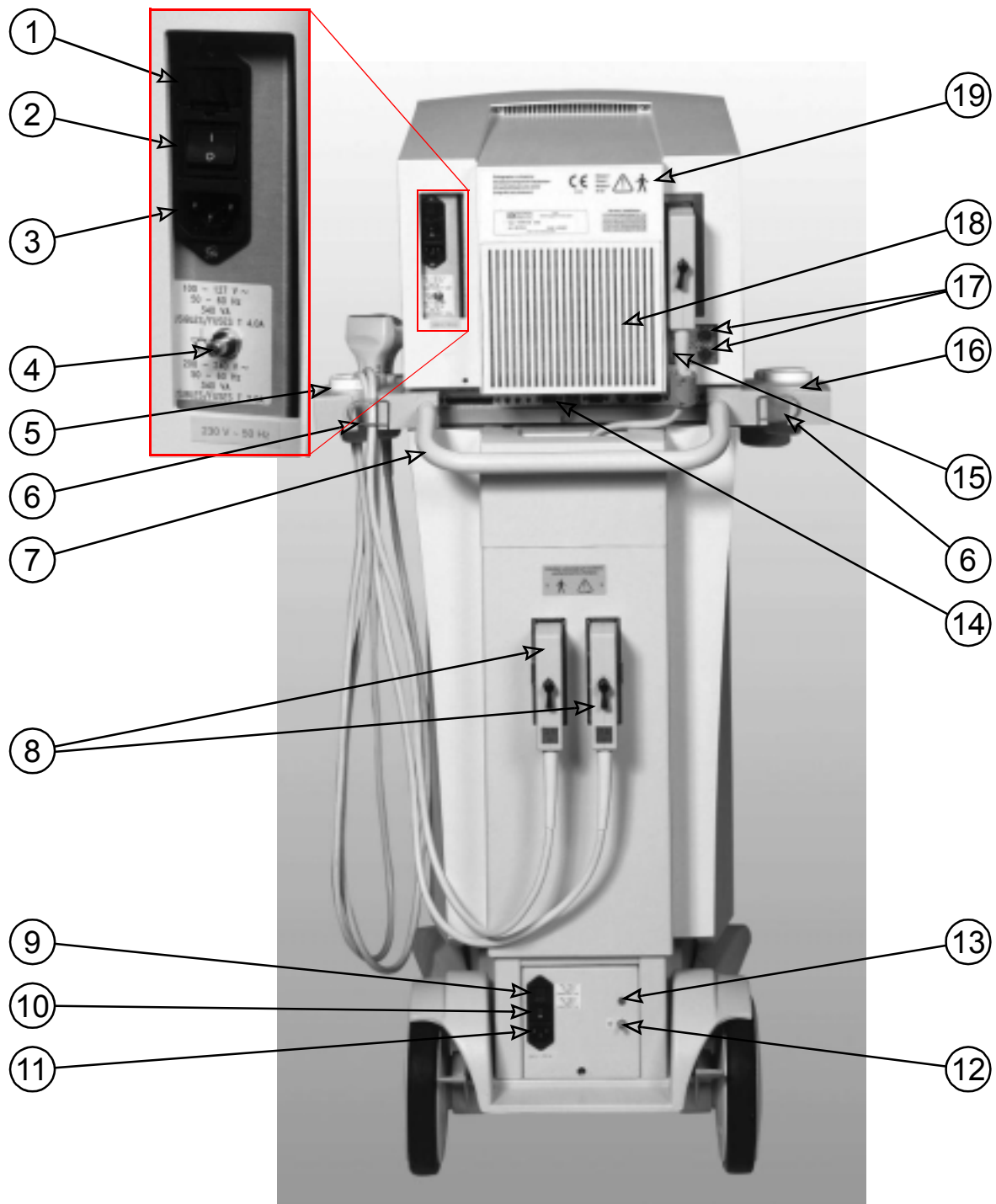

Figure 1-10: SIGMA 330 Expert rear panel

1.3.5.2 SIGMA 330 Excellence Rear Panel

1. Fuses (Electronic cabinet - top part)
2. Switch ON/OFF (Electronic cabinet - top part)
3. Mains plug (Electronic cabinet - top part)
4. Equalization potential terminal (Chassis Ground)
5. Probe holder
6. Guide for probe cable
7. Handle
8. Connectors for Linear/Curved Probes
9. Fuses (SIGMA 110/330 cart - bottom part)
10. Switch ON/OFF (SIGMA 110/330 cart - bottom part)
11. Mains plug (SIGMA 110/330 cart - bottom part)
12. Equalization potential terminal (Chassis Ground)
13. Equalization potential terminal (Chassis Ground)
14. Connector panel
15. Connector for Doppler Pencil Probes
16. Receptacle for bottle of gel
17. Connectors for Annular Sector Probes
18. Air filter grid
19. Identification labels:
 - at the top: (CE mark, model, reference, serial number, revision number)
 - at the bottom: (model, reference, serial number)

Output power: 3 outlets for peripherals (see Chapter 2.7.2, “Output Power Source”, on page 2-11)

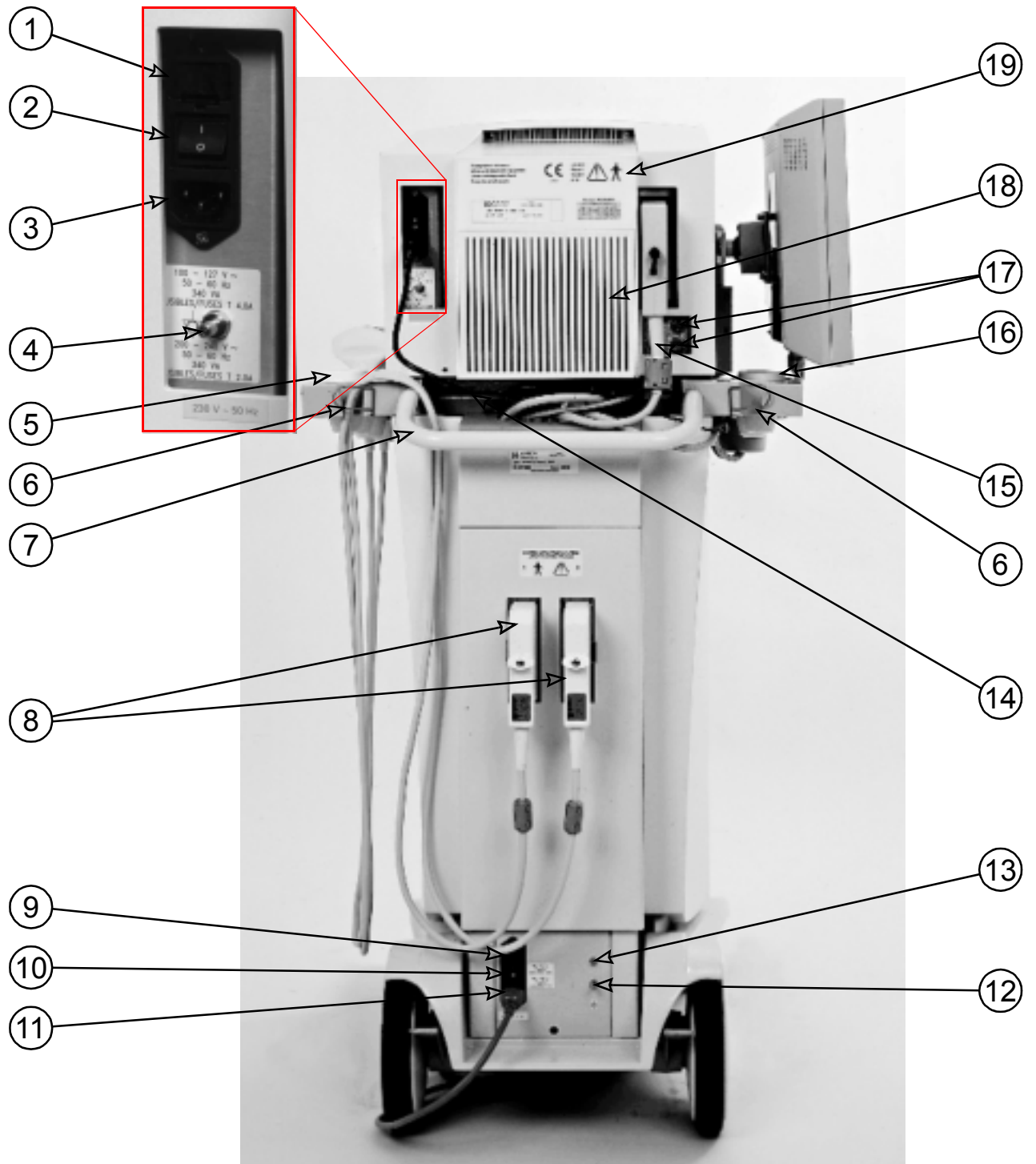

Figure 1-11: SIGMA 330 Excellence rear panel

1.3.5.3 SIGMA 110 Light, Master and SIGMA 330 Master Rear Panel

1. Fuses (see Chapter 2.7.1, "Input Power Source", on page 2-10)
2. Switch ON/OFF
3. Mains plug
4. Probe holder
5. Bottle of gel receptacle
6. Equalization potential terminal (Chassis Ground)
7. Identification label (CE mark, model, reference, serial number, revision number)
8. Connector for Linear/Curved Probes (Master)
9. Air filter grid
10. Connectors for Annular Sector Probes
11. Connector for Doppler Pencil Probes
12. Connector panel

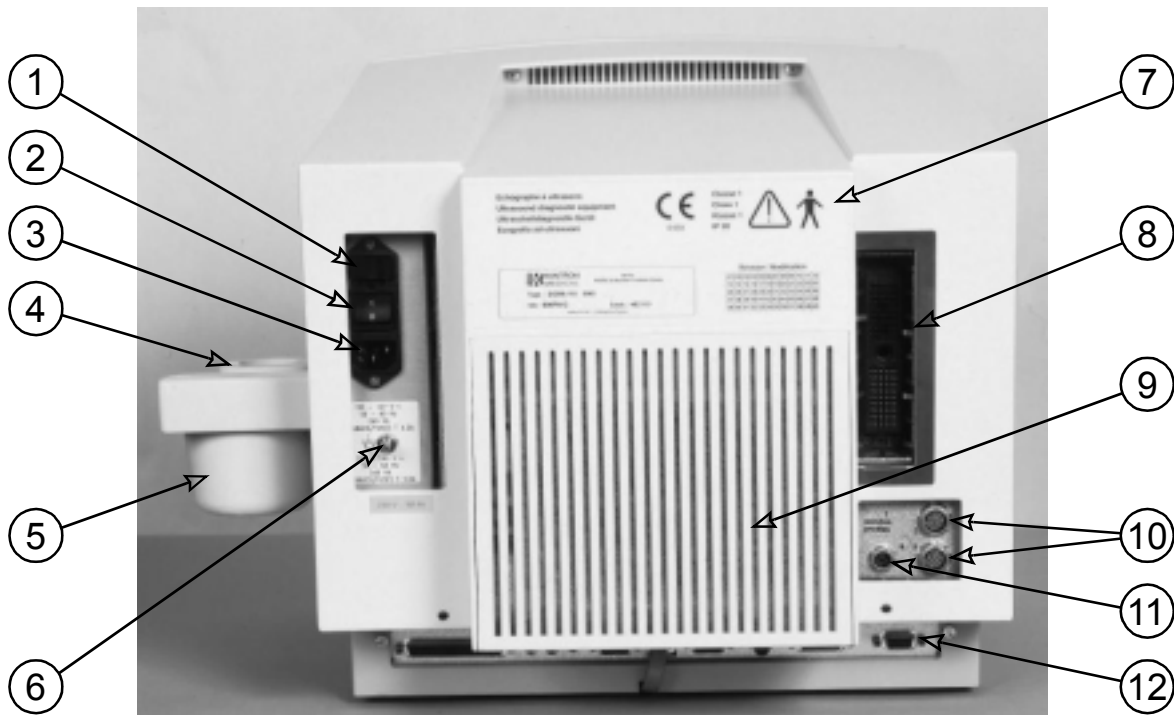

Figure 1-12: SIGMA 110 Light, Master and SIGMA 330 Master rear panel

1.3.5.4 Connector Panel

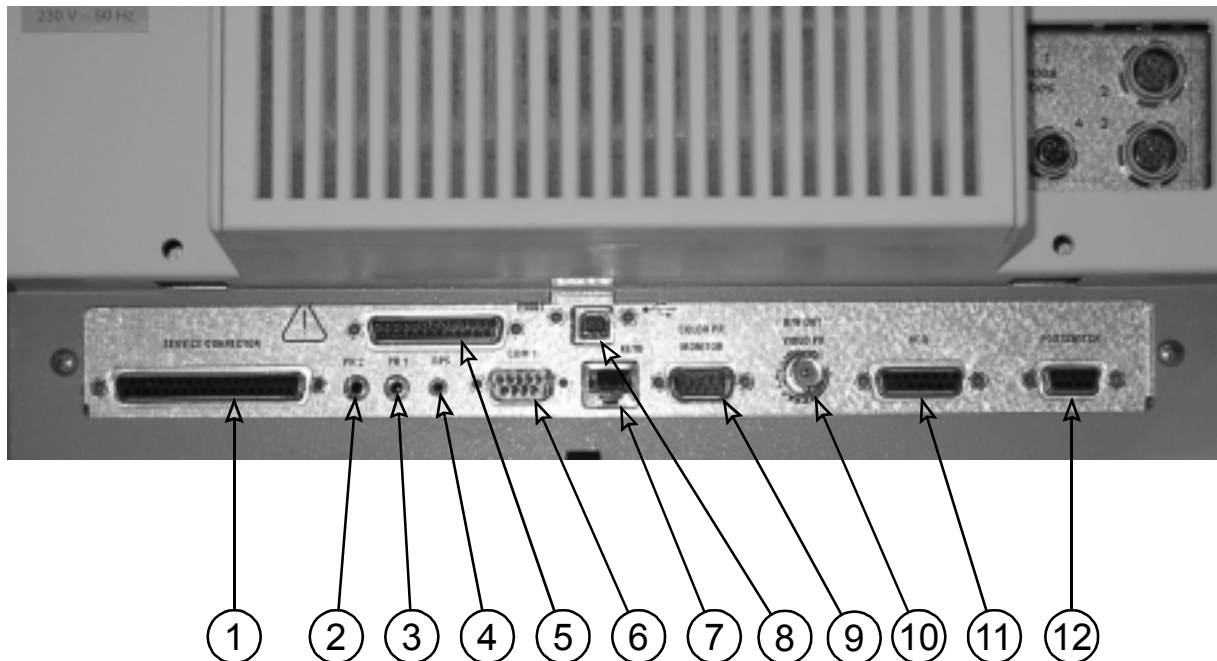

Figure 1-13: Connector panel

Before connecting any equipment to these connectors read carefully, "Chapter III.1, "Intended Clinical Use", on page -xv" and Chapter III.2, "Safety Information", on page -xviii.

1. Service connector
2. Video printer 2 remote control
3. Video printer 1 remote control
4. Remote Power Switch
5. Line Printer (parallel Port)
6. Serial Interface COM1, ECG
7. Keyboard
8. USB Port
9. Monitor
10. Video printer
11. SVHS VCR & Audio Input/Output
12. Foot switch

1.4 System Controls

Definition of the control keys shown in figure 1-4, “Keyboard”, on page 1-13:

1.4.1 Alphanumeric Keys

Alphanumeric keys access to all upper case characters. Useful graphic characters are accessed with using of the **SHIFT** key.

1.4.1.1 ESC Key

The **ESCAPE** key is a generic key that:

- leaves any menu and return to the previous one.
- aborts any string (entry and restore the previous one, if possible).
- is available as often as possible to give user possibility to correct its manipulation errors.
- aborts current measurement.
- returns to previous study sheet or exits report when first sheet is displayed.

1.4.1.2 POWER ON/OFF Key

The **POWER** key switches ON or OFF system power. For Power OFF a confirmation menu is displayed, with a key for action aborting. This is to prevent a user manipulation error.

1.4.1.3 MENU Key

The **MENU** key is a toggle key displaying and hiding the menu of current functions. This menu is depending on the current state and mode.

The (<) **PREVIOUS** and (>) **NEXT** keys located close right of the function keys, are used to access the next/previous menu page if other menu pages are available.

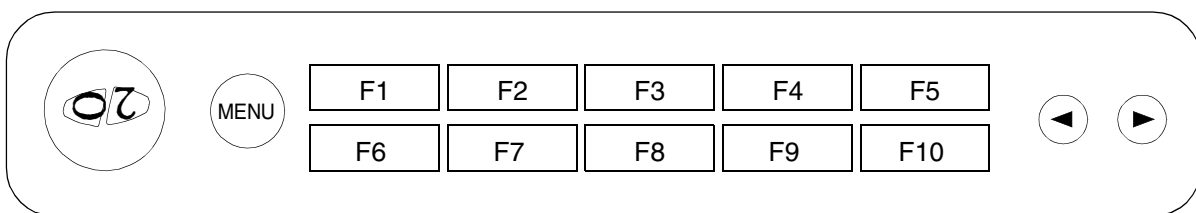

1.4.1.4 F1 to F10 Keys

Select functions displayed in menu on the screen. If it is an action-function, the action is immediately performed.

If it is an adjustment function (this can be recognized by the \updownarrow symbol on screen), the user has to make an adjustment using the potentiometer on the left of the function keys.

1.4.1.5 ID Key

The **ID** key calls the starting page and menu for entering new patient information, laboratory and operator identification.

1.4.1.6 *PROBE*

The **PROBE** key displays the probe MENU showing the names of the connected probes. User can select the operating probe. On probe selection, the corresponding probe setups are loaded and live image starts.

1.4.1.7 *SETUP Key*

The SETUP key displays a menu giving an user action choice on setups and preferences.

- **Load SETUP:** replaces working parameters of current probe by parameters saved in the SETUP.
- **Save SETUP:** Save working parameters of current probe as preset values.
- **Preferences:** Date & Time, Doppler Scale (m/s or kHz), Printer Selection, Patient ID, Technical Data, Cine Mode and Refresh setup.

1.4.2 **Live Investigation Keys**

1.4.2.1 *FREEZE Key*

The FREEZE key is a toggle key starting and stopping image scanning. This key is always enabled. Action on freeze key displays menu of current mode on the screen. When the report is displayed, action on freeze key exits report and displays live ultrasound image.

This key includes a relief mark for easy tactile recognition.

1.4.2.2 *PRINT1 and PRINT2 Keys*

The PRINT1 and PRINT2 key control video printers.

The **PRINT1** key is always enabled and attached to a B&W video printer.

The **PRINT2** key can be configured for colour video printer or for digital archiving (KIPRISM). The configuration can be done with the SETUP menu.

Just before start printing, the live image is frozen and any menu removed from the screen. Just after printing, previous system state is automatically restored.

1.4.2.3 *2D Key*

The 2D key sets the system in 2D mode (not all probes are 2D compatible).

1.4.2.4 *TM Key*

The TM key sets the system in TM mode (not all probes are 2D compatible).

1.4.2.5 *CFM Key*

The CFM key sets the system in CFM mode (only if linear probes are attached to the system, mechanical probes can not be used for CFM).

This key exists only on SIGMA 330 systems + option CFM.

1.4.2.6 PW Key

The PW key sets the system in PW mode.

1.4.2.7 CW Key

The **CW** key sets the system in CW mode. (not all probes are CW compatible, see table i, “Probe applications,” on page -xvi)

1.4.2.8 MAGNIFY Key

The **MAGNIFY** key is used to display an ultrasound image area magnified by a factor 2 in live or freeze mode in 2D/CFM mode.

1.4.2.9 SELECT Key

The **SELECT** key acts when 2 or more images are displayed on the screen. It freezes current image pad, if needed, and sets in live mode the next one.

1.4.2.10 GAIN Pots

The **GAIN** pots change the gain of the current image (2D, TM, CFM, PW or CW). It has no action in freeze mode. Out of the gain range limits, the system emits a sound beep to warn the user. The gain pot which is currently active, is backlit.

1.4.2.11 TGC Pots

The **TGC** (Time Gain Control) is achieved by 5 sliders (rectilinear potentiometers). Five zones are vertically defined on the image. Each slider corresponds to one of the 5 zones and adjusts the gain in this one. TGC acts only in 2D and TM.

1.4.2.12 DEPTH Pot

The **DEPTH** pot changes depth of current image (2D or TM). It has no action in freeze mode. Out of the depth range limits, a beep sounds to warn the user.

1.4.3 Keys for Frozen Image Study

1.4.3.1 BODYMRK

The **BODYMRK** key displays the current body marker set according to the current medical application

1.4.3.2 ANNOTATE

The **ANNOTATE** key displays or hides the annotation menu on the screen and automatically freezes image. Annotation menu enables annotation writing, displays cursors or body markers on the screen.

1.4.3.3 MEASURE

The **MEASURE** key displays or hides the measurement menu on the screen and automatically freezes ultrasound image.

1.4.3.4 REPORT

The **REPORT** key enters or exits the report screen and automatically freezes image. When exiting report, the system returns to frozen ultrasound image display.

1.4.4 Trackball

The trackball and the 3 trackball buttons are linked together. These buttons have different functions:

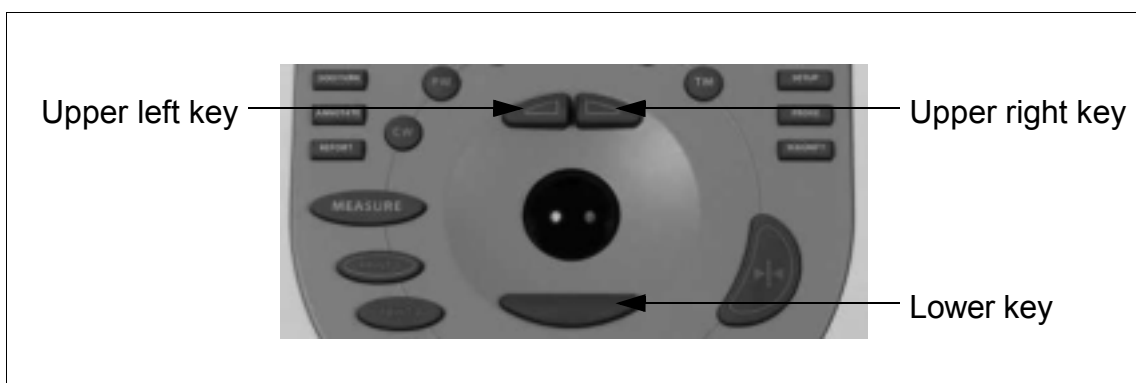

The actions associated to those keys are:

- Upper left key is used to select the next available action in the action list,
- Upper right key is used to select the previous available action in the action list,
- Lower key is used to select the position cursor.

Action lists are managed in a circular manner: if the upper right (upper left) key is pressed and if the current selected action is the last one (the first one) then the next selected action will be the first (last) action of the actions list.

This convention is used for each mode except for:

- Measurement,
- Biometry,
- Annotation,
- Pop-up menus,
- KIPRISM (see, Chapter 3.11.2.3, “Principles of Selection and Validation”, on page 3-53)
- PC Mode (see, Chapter 3.20.4, “PC remote control features description”, on page 3-111)

Some functions are linked to the trackball:

- Magnify and Zoom: moves zoomed or magnified area.
- Annotation/add text: set position of cursor.
- Annotation/Arrow mark: set arrow position on image.
- Measures.

- Patient menu.
- Report.

The trackball is not attached to several functions simultaneously (except in PW live mode).

The trackball is attached to the last selected function. When the current function ends, the trackball attachment returns to the previous one.

1.4.4.1 Positioning of the Cursor

In any imaging mode, live and freeze, the user can move a "Position Cursor" on the screen to point to a region of interest.

Press the lower key to display the cursor and move it using the trackball.

Press the lower key again to erase the cursor and return to previous function.

1.5 Screen Layout

1.5.1 Ultrasound Screen Layout

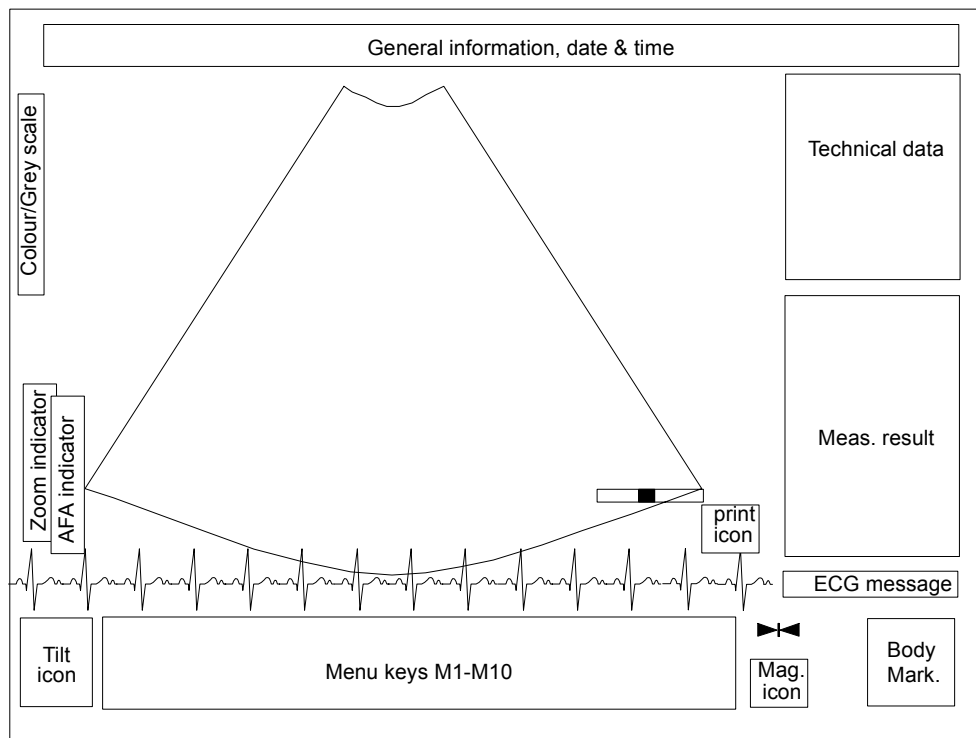
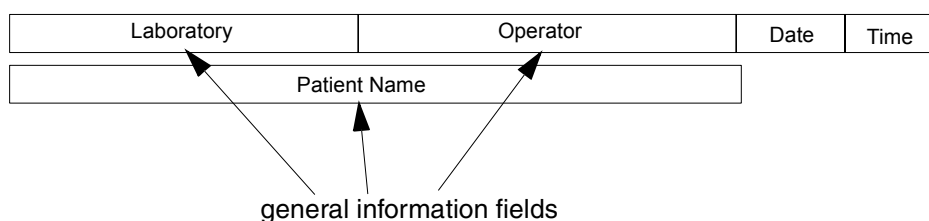

Figure 1-14: Screen Layout

1.5.1.1 General information and Date & Time

In this area following information are displayed:

- the laboratory references
- the operator name
- the patient name
- the current date and time



According to the user preferences (set in the setup menu), the content of the general information fields can be displayed or not. These fields are set in the Patient ID form.

The content of the laboratory and the operator fields are saved in the Non Volatile RAM and displayed at each start-up.

1.5.1.2 Colour/Grey Scale

According to the current mode (2D or CFM mode), the colour and/or the grey scales are displayed on the left part of the screen. The display rules of both scales are the following:

- scales are never displayed in full TM mode
 - scales are displayed in all the other modes when no overlapping between the scales and the ultrasound image is possible.
 - scales have an height of 128 pixels in single 2D or CFM and 80 pixels in the other modes.
- The grey scale
From the 128 (CFM mode) or 256 (2D mode) ultrasound possible grey levels only 16 are displayed in the grey scale.
Remark: in CFM mode the displayed grey scale has the half of the width of the grey scale displayed in 2D.
- The colour scale
The colour scale is only displayed in CFM modes (single or multi-pad modes) and is always associated to the grey scale (when colour scale is displayed, grey scale also displayed). In this mode, two different types of colour scales can be displayed.
- the 128 colour levels are displayed in Power and Velocity mode
 - if imaging of turbulence is activated in Velocity mode 32 colour levels and 96 turbulence levels distributed into 128 colours are displayed.

The colour baseline shift has no influence on the number of displayed colours, which is always equal to 128 levels.

Colour & Grey scale design

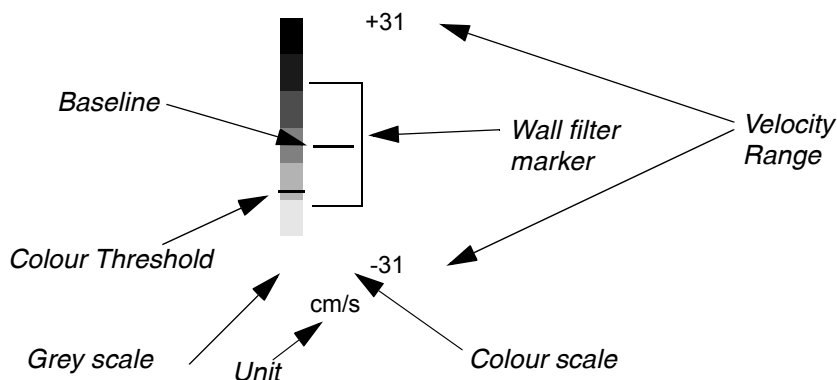

1.5.1.3 Technical Data





See Chapter 1.5.3, "Technical Data Area", on page 1-38.

1.5.1.4 Measurement Results

See Chapter 3.14, "Measurements", on page 3-67.

1.5.1.5 Icons

Four types of icons can be displayed on the SIGMA screen:

- the freeze symbol icon  displayed when the system is frozen
- the magnify icon  displayed when the 2D or CFM image is magnified
- the tilt icon  displayed with tiltable probes (6.5 EV). This symbol indicates the current scanned part
- the print icon  temporary displayed when the user press on one of the two print keys

1.5.1.6 Zoom Indicator

On the left side of the menu the range scale is drawn. This scale locates the zoomed part of the 2D image. By moving the trackball up or down the current displayed area will be moved and the zoom range indicator will be modified.

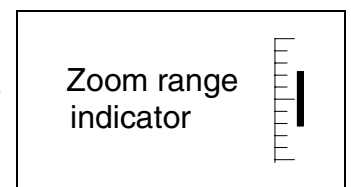

1.5.1.7 ECG

Menu and ECG pads are always displayed one above the other. The menu is always displayed.

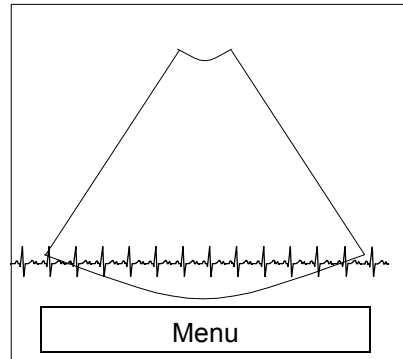

The colour of the ECG trace is CYAN with a colour monitor and WHITE with a B/W monitor.

1.5.1.8 Auto Frequency Adjustment (AFA)

The Auto Frequency Adjustment marker (A.F.A.) shows the current ultrasound working frequency bandwidth of the transducer in 2D. This working frequency bandwidth depends on actual selected scan depth and on the Freq+/Freq- setting. For each transducer, depth and frequency setting, A.F.A selects the optimal frequency bandwidth of the transducer.

A.F.A. is available in single 2D mode and Freeze mode.

AFA display is selectable in the Preferences Menu.

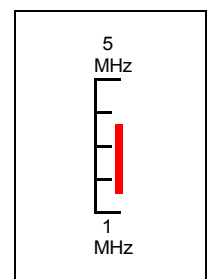

1.5.2 Menu

1.5.2.1 Function Key Menu

Function Keys on the keyboard are named F1 to F10 and Menu Items on the screen M1 to M10 to get understanding of the following description easier.

MP, as Menu Potentiometer, is for the incremental potentiometer.

MK is for the MENU key.

(<) is for the PREVIOUS key

(>) is for the NEXT key.

Function Keys F1 to F10 are respectively attached to the corresponding Menu Items M1 to M10 (e.g. pressing F1 acts on M1)

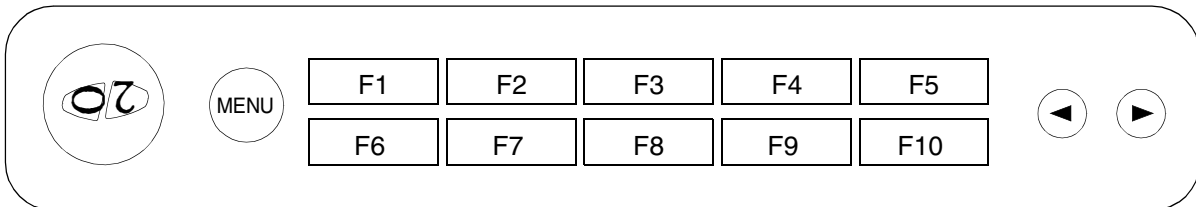

Figure 1-15: Function Keys

A specific menu exists for each mode. The current menu is automatically displayed when entering mode. For example, pressing 2D key enters 2D mode and displays 2D menu. MK key is used to display or hide menu. (<) (>) keys are used to access previous/next menu page when more than one is available.

There are two types of displayed menu: single or double.

- Single Menu is displayed on 1 line and consists of 5 Menu Items M1 to M5.

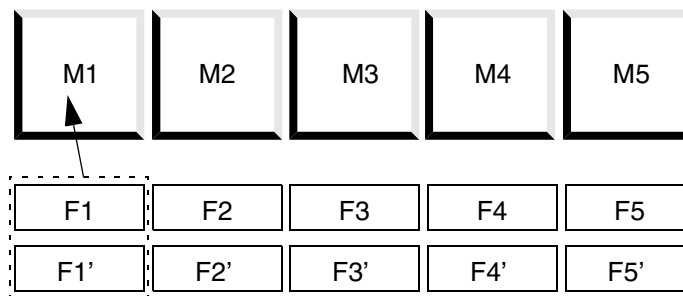

Figure 1-16: Single Menu Display

For Single Menu the Fi and Fi' keys have the same action. Press indifferently F1 or F1' to select M1 menu item.

- Double Menu is displayed on 2 lines and consists of 10 Menu Items M1 to M10.

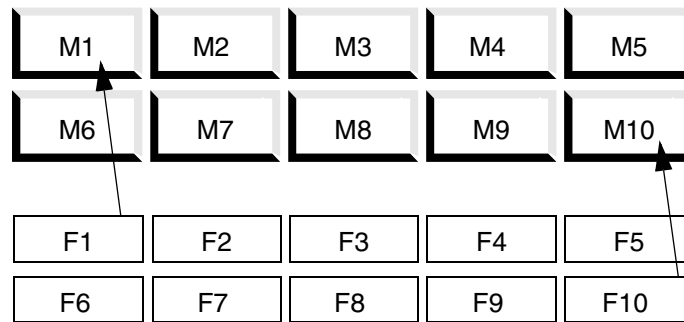

Figure 1-17: Double Menu Display

1.5.2.2 *PopUp Menu Used for Labels and Body markers*

When activating label or body marker menu, a list is displayed in place of the technical and measurement data. More details on labels and body marker management are available in Appendix L, “Body Markers”, on page 7-111

1.5.3 Technical Data Area

This chapter describes technical data of SIGMA 110/330 in the different modes.

In multi-pad mode, the common parameters (i.e. Gamma, Smooth, ...) are the ones of the active pad.

1.5.3.1 Technical Data Formats

Most of parameter values are preceded by a character label so that the user can easily identify their meaning. In the following sections the different value formats are described: xx means that 2 characters are displayed.

□ Non labelled data

- Probe: probe name (including its working frequency).
- Application: the probe medical application.
- Sub-Application in CFM mode¹: name of the selected CFM Sub-Application (Liver & Vein, Kidney, Abdom. Artery, Periph. Artery, Periph. Vein and Fetal Heart) or the scanning method (Scan Fast or Scan Normal in Cardio).
- Depth: **xx cm**
- Quality: **Freq+** or **Freq-**
- Doppler frequency (SPFreq): **x MHz**
- Doppler mode: **CW** or **PW**
- CFM frequency (CFMFreq): **x.xMHz**
- Frame rate in 2D and CFM mode: **xx fps**

□ Labelled data

- 2D Gain: **BGainxx**
- Gamma: **Gamma x**
- Rainbow: **Rainb x**
- Enhance: **Enh x**
- Reject: **Rej x**
- Smooth: **Smoothx**
- Zoom Factor: **Mag x.x**
- Gate size: **Gatexmm**
- Spectral Wall filter: **WxxxxHz**
- Vector: **Vec+xx°**
- Doppler Gain: **DGainxx**
- Spectral Energy: **En -xxdB**
- CFM Gain: **CGainxx**
- Resolution: **Res Low, Res Med** or **Res Hi**
- Persistence: **Pers x**

1. The parameter Sub-application is different from the biometry Medical Application. The later is only relevant to annotation, body marker, measurement and biometry modules.

- Colour Map: **ColMapx**
- CFM Energy: **En -xxdB**
- Thermal Index¹: **TISx.x** or **TIBx.x** (or **MI x.x** when the probe is a pencil probe or **TIC x.x** when the probe is a TCD2 probe).
- Mechanical Index: **MI xx.x**

1.5.3.2 2D and [2D]/TM Technical Data

The techdata for the 2D and [2D]/TM modes are organized as described below:

Probe	Probe	Appl. name	Application
Depth	xx cm	BGainxx	2D Gain
Quality	Freq+	Smooth x	Smooth
Enhance	Enh x	Rej x	Reject
Gamma	Gamma x	Rainb x	Rainbow
Zoom Factor	Mag x.x	xx fps	Frame Rate
TI/MI	TI xx.x		

The “Zoom Factor” field is optional: it contains the zoom or the magnify factor and will only be displayed if Mag or Zoom is on.

1.5.3.3 2D/[TM] Technical Data

These ones contains the 2D data (except the “Zoom Factor”) and the TM data:

Probe	Probe	Appl. name	Application
Depth	xx cm	BGainxx	2D Gain
Quality	Freq+	Smooth x	Smooth
Enhance	Enh x	Rej x	Reject
Gamma	Gamma x	Rainb x	Rainbow
		xx fps	Frame Rate
TI/MI	TI xx.x		

1.5.3.4 TM Technical Data

In this mode, only the information relevant to the TM single pad are displayed:

Probe	Probe	Appl. name	Application
Depth	xx cm	BGainxx	2D Gain
Quality	Freq+		
Enhance	Enh x	Rej x	Reject
Gamma	Gamma x	Rainb x	Rainbow
TI/MI	TI xx.x		

1.5.3.5 Double 2D and Quad 2D Modes

In these modes the technical data window contains the information concerning the active image. See Chapter 1.5.3.2, “2D and [2D]/TM Technical Data”, on page 1-39.

1. Only one of the thermal or the mechanical index will be displayed at a time.

1.5.3.6 2D/SP, 2Di/SP Technical Data

These technical data contains the 2D data and also the PW ones:

Probe	Probe	Appl. name	Application
Depth	xx cm	BGainxx	2D Gain
Quality	Freq+	Smooth x	Smooth
Enhance	Enh x	Rej x	Reject
Gamma	Gamma x	Rainb x	Rainbow
Zoom Factor ^a	Mag x.x	TI xx.x	Frame Rate
PW/CW	PW	DGainxx	Doppler Gain
SPFreq	x.x MHz	Vec+xx°	Vector
SPWall Filter	WxxxxHz	En -xxdB	SP Energy
GateSize ^b	Gatexxmm	TI xx.x	
Tlx/MI ^c			

- a. Zoom mode only
- b. PW mode only
- c. only displayed when image is active and live

1.5.3.7 CFM and [CFM]/TM Technical Data

The most relevant CFM information are displayed here:

Probe	Probe	Appl. name	Application
Sub-Application	Subappl. name		
Depth	xx cm	CGainxx	CFM Gain
Resolution	Res Low	Pers x	Persistence
CFMFreq	x.x MHz	xx fps	Frame Rate
Color Map	ColMapx	En -xxdB	CFM Energy
2D Gain	BGain xx		
Zoom Factor ^a	Mag x.x		
Tlx ^b	TI xx.x		

- a. only if Mag or Zoom is on
- b. in live mode only

When “Color Off” is pressed, the 2D technical data are displayed (See Chapter 1.5.3.2, “2D and [2D]/TM Technical Data”, on page 1-39).

1.5.3.8 CFM/[TM] Technical Data

See Chapter 1.5.3.3, “2D/[TM] Technical Data”, on page 1-39

1.5.3.9 [CFM]/SP Technical Data

The CFM information is inserted in the 2D/SP techdata:

Probe	Probe	Appl. name	Application
Sub-Application	Subappl. name		
Depth	xx cm	CGainxx	CFM Gain
Resolution	Res Low	Pers x	Persistence
CFMFreq	x.x Mhz	xx fps	Frame Rate
Color Map	ColMapx	En -xxdB	CFM Energy
2D Gain	BGainxx		
PW/CW	PW		
SPFreq.	x.x MHz	DGainxx	Doppler Gain
SPWall Filter	WxxxxHz	Vec+xx°	Vector
GateSize ^a	Gatexxmm	En -xxdB	SP Energy
TI/MI ^b	TI xx.x		

- a. PW mode only
- b. in live mode only

When the “Color Off” key is pressed, the 2D/SP technical data are displayed (Chapter 1.5.3.6, “2D/SP, 2Di/SP Technical Data”, on page 1-40).

1.5.3.10 CFM/[SP] Technical Data

Chapter 1.5.3.6, “2D/SP, 2Di/SP Technical Data”, on page 1-40

1.6 Display Modes

1.6.1 2D Modes

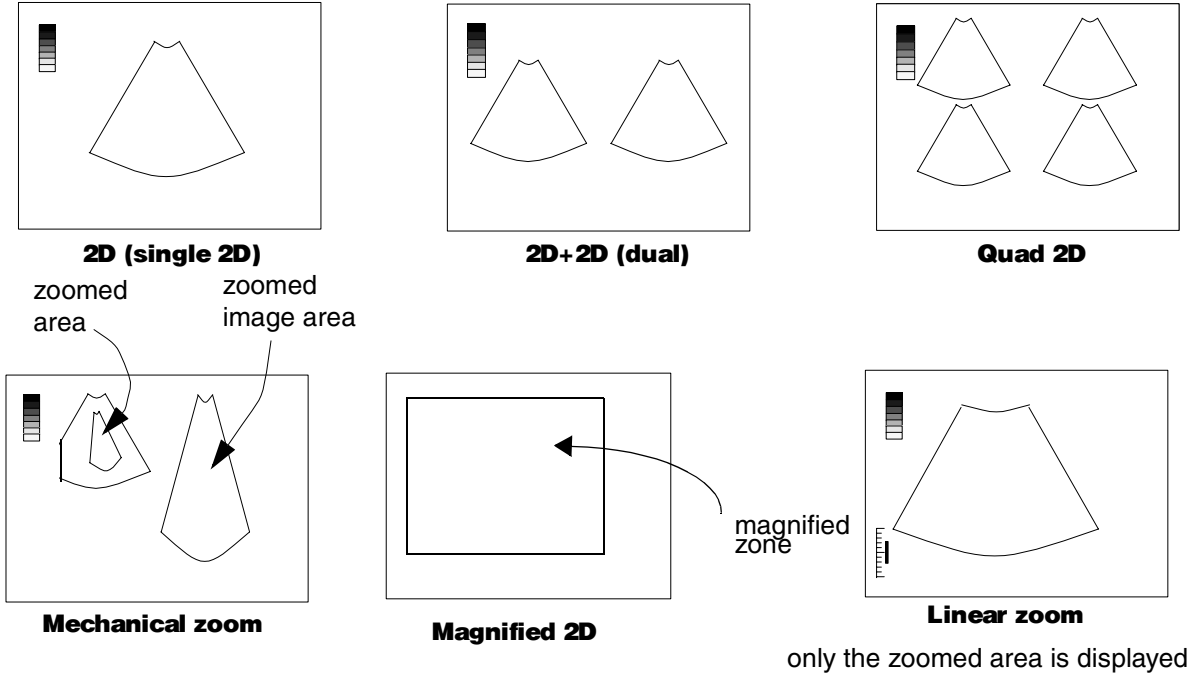

Figure 1-18: 2D Display Modes

1.6.2 TM Modes

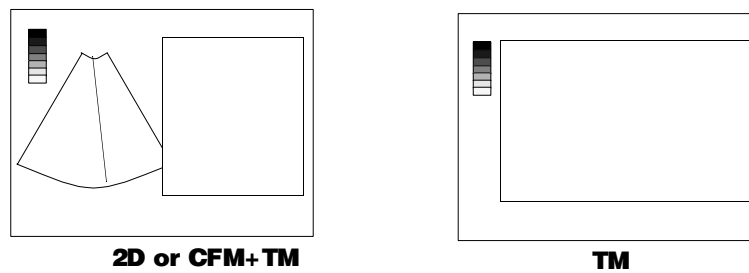

Figure 1-19: TM Display Modes

1.6.3 CW and PW Modes

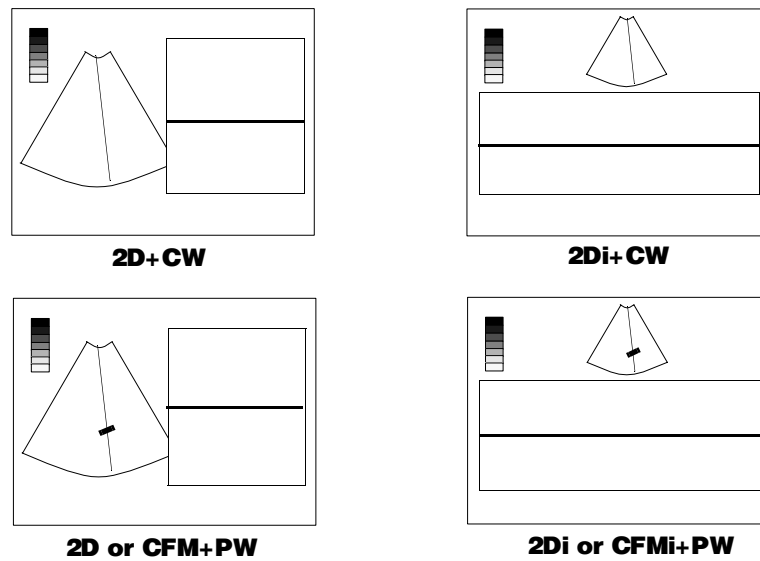

Figure 1-20: CW and PW Display Modes

Remark: the CFM+CW modes are not available because the CFM is only possible with linear probes and the CW mode only with mechanical or pencil probes.

1.6.4 CFM Formats

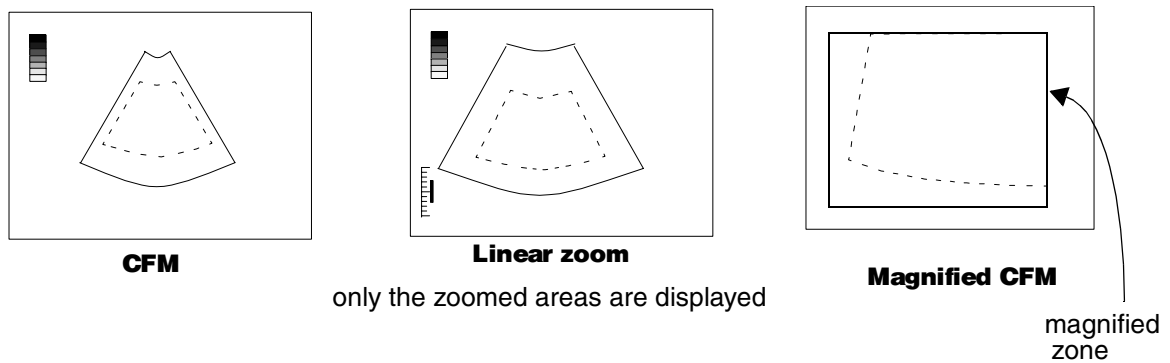

Figure 1-21: CFM Display

These formats are only available for linear transducers. It is composed of 2 images displayed one over the other: the 2D image (on the back) and the Colour Flow Mapping image (on the front)

1.7 SIGMA 110 Technical Specifications

1.7.1 General

The SIGMA 110 is a 2D, TM and spectral Doppler transportable ultrasound scanner for general purpose applications:

- Abdominal
- Breast
- Cardiology
- Emergency
- Endocrinology
- Gastro-enterology
- Gynaecology
- Obstetrics
- Paediatrics
- Small parts
- Musculoskeletal
- Neonatology
- Urology
- Vascular

SCANNING TECHNIQUES

- Electronic linear scanning
- Electronic convex scanning
- Annular array sector scanning
- Doppler Pencil probes

DISPLAY MODES

- Real time 2D (B-Mode) display modes:
 - Single 2D format
 - Double 2D format
 - Quad 2D format
 - 2D panoramic zoom (for mechanical probes only)
 - 2D scroll zoom (for LINEAR/CONVEX probes only)
 - 2D magnification
- TM (M-Mode) display modes:
 - Quasi Duplex 2D + TM: 2D (50% screen) + TM (50% screen)
 - Full screen TM
- CW display modes:
 - Quasi Duplex 2D + CW: 2D (50% screen) + CW (50% screen)
 - 2Di (icon) + CW
- PW display modes:

-
- Quasi Duplex 2D + PW: 2D (50% screen) + PW (50% screen)
 - 2Di (icon) + PW

MONITOR

- Black & White monitor, 10" diagonal
- 640 x 480 pixels resolution
- Direct management of brightness and contrast
- includes loudspeakers and control knob for volume

KEYBOARD

- Six languages: English, French, German, Italian, Spanish and Russian (Cyrillic)
- Backlighting of all keys and knobs
- Ten software controlled function keys for menu selection
- Full alphanumeric capabilities
- B/W video printer remote control
- Trackball for focus point setting, TM, CW/PW line steering, annotations positioning, measurements, cine-mode review and arrow pointing
- Layout removable for cleaning operation
- Trackball removable for cleaning operation

INFRARED REMOTE CONTROL (option)

- Ensure system control in any inadequate examination condition
- Allow the remote control for scanning parameters, freeze and image printing
- Dedicated place on keyboard

SCREEN LAYOUT

- Patient identification field including patient name clinic name, operator name, time and date
- Technical data field showing all pertinent imaging parameters
- Measurement field displaying the last ten measurement results
- Menu field activated by the corresponding function key
- Freeze mode indicator
- Cine-loop memory index (option)
- Annotation arrows and user defined annotations with trackball controlled positioning
- Image orientation indicator
- Over 51 body markers with scan plane indication
- Dot lines for TM/CW/PW beam orientation
- Real time ECG trace display
- Biopsy channel indication with automatic calibration of depth, probe type, left/right guides and angle up/down orientation

SETTINGS

- Default settings related to the medical application and transducer for image quality optimization
- User settings memorized in the system as well as on a flash card

1.7.2 2D (B-Mode)

SCANNING SECTOR

- Angle: 40, 45, 60, 75, 90, 110 and 140° for Annular Sector (Probe dependent)
- Angle: 30, 45, 60, 75, 90 and 110° for Convex Array (Probe dependent)
- Depth: 2 cm to 24 cm, up to 10 depths (Probe dependent)
- Nominal frequency range: 2 to 14 MHz (Probe dependent)

FRAME RATE

- Up to 200 fps (probe and medical application dependent)
- Depending on depth, angle and medical application

SIGNAL PROCESSING

- Large bandwidth: 1.5 - 18 MHz
- Overall Gain: 32 steps
- Time Gain Compensation: 5 sliders
- Dynamic focusing on reception
- Up to four focus zones on transmission
- Automatic adjustment of reception bandwidth for each depth
- Contour enhancement: 7 positions application dedicated
- Dynamic range control (reject): 4 positions to increase the contrast and reduce weak echoes
- Frame filter: 4 non linear smoothing filters + OFF position
- Automatic Frequency Adjustment (A.F.A.) for standard and less echogenic patient (Freq+/Freq-)
- Grey scale optimization thanks to 8 Gamma curves (probe dependent)

IMAGE PRESENTATION

- Single, Double and Quad image representation
- Freeze mode
- Left/right
- Up/Down
- Video inversion

RESOLUTION

- 512 x 512 pixels on screen for 2D image display
- 256 grey levels

IMAGE MEMORY (option)

- Cine Mode: up to 282 images (probe and medical application dependent)

1.7.3 TM (M-Mode)

SIGNAL PROCESSING

- Same as 2D mode

IMAGING PARAMETERS

- Scrolling speed:

- 2, 3, 5, 8 sec./screen (full screen)
- 1, 1.5, 2.5, 4 sec./screen (2D + TM)

M LINE STEERING

- Trackball controlled over complete 2D sector

DISPLAY

- 2D (50% screen) + TM (50% screen)
- Full screen TM

IMAGE MEMORY

- Cine Mode:
 - up to 16 trace screens in full TM
 - up to 5 trace screens in 2D + TM

1.7.4 Spectral Doppler Mode

AVAILABLE MODES

- Steerable PW
- Steerable CW

SIGNAL PROCESSING

- Multi-frequency Doppler mode: 2, 3, 4 and 8 MHz (probe dependent)
- Velocity range:
 - PW: +/-1 kHz to +/- 10 kHz
 - CW: +/-1 kHz to +/- 20 kHz
 - +/- 10 cm/sec. to +/- 3.5 m/s (PW), +/- 7.2 m/sec. (CW), full scale, depending on probe and operating frequency
- High pass wall filter: 10 cut-off frequencies adjustable between 50 to 1000 Hz
- Grey scale optimization with 8 post-processing curves (probe dependent)
- Spectrum gain control: 11 selections between 0 and 30 dB
- 120 dB dynamic range for best sensitivity
- 256 point FFT, computing time of 0.2 ms
- Doppler transmit power control: 8 selections between 0 dB and -21 dB
- Doppler angle correction: from -80 to 80 °
- Scrolling speed:
 - 2, 3, 5, 8 sec./screen (full screen)
 - 1, 1.5, 2.5, 4 sec./screen (2D + SP)
- Adjustable audio volume

PW GATE

- PW gate adjustable for sample volumes between 1 and 15 mm (8 selections)
- PW gate adjustable with the trackball between 0 and maxi depth of the image format

DISPLAY

- 2D (50% screen) + Doppler (50% screen)
- 2D icon + Doppler

- Base line shift: 9 positions for optimal signal display, avoiding spectrum aliasing
- V_{MEAN} real time trace display
- V_{MAX+} and V_{MAX-} real time trace display
- Quasi duplex automatic refresh: 4 levels, according to scrolling speed

IMAGE MEMORY

- Cine Mode:
 - up to 16 trace screens in full Doppler
 - up to 5 trace screens in 2D + Doppler

ACOUSTIC POWER OUTPUT

- Fulfills acoustic output display standards
- Complies with FDA acoustic output limits
- Automatic power output adjustment versus medical application for optimal Doppler performance (ALARA)
- User selectable Doppler transmit power attenuation: 8 positions between 0 dB and -21 dB

1.7.5 Digital Archiving: KIPRISM

- Digital archiving on Memory Card: the number of ultrasound images which can be stored, is depending on memory card capacity
 - up to 32 images on 4 megabytes memory card
 - up to 64 images on 8 megabytes memory card
 - etc.
- Transfer on Personal Computer via memory card (PCMCIA standard, DOS format)

1.7.6 ECG Module (option)

FORMATS

- for all single or dual pad formats

INPUT

- Isolated input, type CF, Defibrillator proof (IEC 601-1)
- through serial port, 240 x 8 bit / second, QRS trigger available
- ECG Gain: 1000 (1V / 1 mV)
- Heart rate: up to 180 bpm
- Recovery time after defibrillator shock: > 5 sec

B MODE TRIGGER

- in single and dual B mode available, trigger moment may be set by user.
- For dual pad modes two independent triggers can be set.

DISPLAY and CINE REVIEW

- Display trace (on video screen)
- Indication of time relationship between 2D mode image and ECG trace by marker on ECG trace. Cine review on trace modes is also available.

1.7.7 EasyPrint™

- Direct output to inkjet printer
- Compatible with HP PCL level III

1.7.8 USB-Link™

- Digital transfer of images and report text files to Personal Computer through USB cable
- Compatibility: refer to Chapter 3.18.2, “Compatibility”, on page 3-99.

1.7.9 Peripherals (Optional)

The following peripherals can be connected to the system:

- VCR (VHS and S-VHS)
- B/W video printer
- Parallel DeskJet printer (PC compatible) for images (EasyPrint™) and report printout
- B/W monitor

1.7.10 Inputs/Outputs

- S-VHS/VHS (including audio) input/output for VCR connection, PAL/NTSC compatible, video playback automatically fed to the monitor
- Black & White video composite output for B/W video printer connection
- Double footswitch (Freeze/ Print/ Select image)
- Memory card connector (PCMCIA) dedicated to software upgrade, user setup storage and digital archiving (KIPRISM)
- RGB video output for external monitor and color video printer
- Parallel port for images and report printout
- Serial port for peripheral devices
- USB port for data transfer to PC

1.7.11 Measurement

CALIPERS

- Trackball controls the multiple callipers
- Complete measurement capabilities on frozen images
- **2D**: distance, surface and circumference of area, surface and circumference of ellipse, angle; distance and area ratio
- **TM**: distance, time, slope, heart rate, distance and time ratio, LV studies
- **PW/CW**: speed gradient, frequency, time, acceleration, integral, PI & RI, RI, heart rate, speed, gradient and time ratio
- Specific measurements for OB/GYN
- Up to 10 result lines on screen

ANNOTATIONS

- Annotation collection
- Text, arrows, body markers

PATIENT REPORT

- Automatic selection of relevant measurement from patient report
- Comprehensive report for each medical application: Radio, Vasc., Ob/Gyn, Pediatrics, Cardio.
- **Peripheral vascular:** stenosis percentage, continuity equation, resistance index, stenosis index, pulsatility index, spectral broadening index, flow volume, frequency
- **Abdominal:** volume 1 to 4 (user-defined), cardiac output, diameter, continuity equation
- **Pediatric:** hip angles
- **Ob/Gyn:** extensive measurements capabilities including BPD, FML, CRL, BOD, ABD, THD, AC, GES, HC, OFD, APD, TAD, Foetal Weight, Estimated Birth Date
- **Cardio:** left ventricular volumetry using Simpson, area length single and bi-plane formulas, systolic and diastolic volume using Teichholz rule, shortening fraction, myocardial mass and mass index, left ventricular circumference, ejection fraction, cardiac output and index, stroke volume and index, mean velocity, pressure and mean pressure gradient, pressure half time and valve area, time to peak velocity in systole, right and left ventricular ejection time and pre-ejection period, right ventricular systolic pressure, continuity equation, QP/QS
- All applications: body surface area (BSA)

MEASUREMENT ACCURACY

Mode:	Parameters:	Typical accuracy:
2D	• Distance	<ul style="list-style-type: none"> • < +/- 3% • 1 mm, when 3% of the measured value is less than 1 mm
	• Angle	< +/- 2.5 °
TM	• Distance	<ul style="list-style-type: none"> • < +/- 1% • 0.5 mm, when 1% of the measured value is less than 0.5 mm
	• Time	< +/- 1%
	• Slope	< +/- 2%
SP	• Speed	< +/- 5% of max. displayed velocity
	• Frequency	< +/- 5% of max. displayed frequency
	• Gradient	< +/- 10%
	• Time	< +/- 1%
	• Acceleration	< 10%
HR	• Heart rate computed by ECG	+/- 1 bpm

Table 1-4: Measurement Accuracy

1.7.12 Acoustic Power

SIGMA 110 complies with the FDA Standards.

Acoustic power depends on Medical Application.

- $I_{SPPA} < 190 \text{ W/cm}^2$ (Medical Application independent)
- $I_m < 310 \text{ W/cm}^2$ (Medical Application independent)
- I_{SPTA} in situ, in mW/cm^2

MEDICAL APPLICATION	CARDIO	VASC.	RADIO, OB/GYN
I_{SPTA} In situ, in mW/cm^2	< 430	< 720	< 94

Table 1-5: Acoustic Intensity

- Accuracy of MI display: +/- 30 %
- Accuracy of TI display: +/- 50 %

1.7.13 Environment

TEMPERATURE

- Operating temperature: 10 °C to 40 °C (50 °F to 104 °F)
- Storage temperature: -20 °C to 40 °C (-4 °F to 104 °F)

HUMIDITY

- Operating humidity: 30% to 80%, non condensing
- Storage humidity: 30% to 95%, non condensing

ATMOSPHERIC PRESSURE

- Operating pressure: 700 mbar to 1060 mbar
- Storage pressure: 500 mbar to 1060 mbar

ELECTRICAL SPECIFICATIONS

- Input voltage: 100 - 127 V~ and 200 - 240 V~
- Mains frequency: 50 - 60 Hz
- Consumption: 340 VA

ELECTROMAGNETIC FIELD

- Maximum field strength without degradation of performance: 1 V/m

1.7.14 Regulation and Safety

- CE MDD mark
- German K.V. regulation
- IEC 601-1 Class 1 Type B (Electrical Safety)
- IEC 1157 (Acoustic power reporting)
- FDA 510 (k)

1.7.15 Dimensions

- Height: 380 mm
- Width: 470 mm
- Depth: 526 mm
- Weight: 29 kg

1.8 SIGMA 330 Technical Specifications

1.8.1 General

The SIGMA 330 is a 2D, TM, Spectral Doppler and Color Flow Mapping ultrasound scanner for general purpose applications:

- Abdominal
- Breast
- Cardiology
- Emergency
- Endocrinology
- Gastro-enterology
- Gynaecology
- Musculoskeletal
- Neonatology
- Obstetrics
- Paediatrics
- Small parts
- Urology
- Vascular

SCANNING TECHNIQUES

- Electronic linear scanning
- Electronic convex scanning
- Annular array sector scanning
- Doppler Pencil Probes

DISPLAY MODES

- Real time 2D (B-Mode) display modes:
 - Single 2D format
 - Double 2D format
 - Quad 2D format
 - 2D panoramic zoom (for AS probes only)
 - 2D scroll zoom (for LINEAR/CONVEX probes only)
 - 2D magnification
- 3D¹
 - 3D-Fetal View™
 - 3D-Vascular View™
- TM (M-Mode) display modes:
 - Quasi Duplex 2D + TM: 2D (50% screen) + TM (50% screen)
 - Full screen TM

1. SIGMA 330 Excellence only

- CW display modes:
 - Quasi Duplex 2D + CW: 2D (50% screen) + CW (50% screen)
 - 2Di (icon) + CW
- PW display modes:
 - Quasi Duplex 2D + PW: 2D (50% screen) + PW (50% screen)
 - 2Di (icon) + PW
- CFM display modes:
 - Single CFM
 - Quasi Duplex CFM + PW: CFM (50% screen) + PW (50% screen)
 - CFMi (icon) + PW
- Colorised 2D, TM, PW & CW mode display

MONITOR

- Colour monitor
 - 10" diagonal
 - 640 x 480 pixels resolution
 - PAL/NTSC compatible
 - Direct management of brightness and contrast
 - includes loudspeakers and control knob for volume
- LCD flat panel colour monitor¹
 - 15" diagonal
 - 800 x 600 pixels resolution

KEYBOARD

- Six languages: English, French, German, Italian, Spanish and Russian (Cyrillic)
- Backlightening of all keys and knobs
- Ten software controlled function keys for menu selection
- Full alphanumeric capabilities
- B/W and colour video printer remote control
- Trackball for TM, CW/PW line steering, PW gate positioning, CFM colour window resizing and positioning, focus point setting, annotation positioning, measurements and cine-mode review
- Layout removable for cleaning operation
- Trackball removable for cleaning operation

INFRARED REMOTE CONTROL

- Ensure system control in any inadequate examination condition
- Allow the remote control for scanning parameters, freeze and image printing
- Dedicated place on keyboard

SCREEN LAYOUT

- Patient identification field including patient name, clinic name, operator name, time and date

1. SIGMA 330 Excellence only

-
- Technical data field showing all pertinent imaging parameters
 - Measurement field displaying the last ten measurement results
 - Menu field activated by the corresponding function key
 - Freeze mode indicator
 - Cine-loop memory index
 - Annotation arrows and user defined annotations with trackball controlled positioning
 - Image orientation indicator
 - Over 51 body markers with scan plane indication
 - Indication of CFM ROI position and size
 - Dot lines for TM/CW/PW beam orientation
 - Real time ECG trace display
 - Biopsy channel indication with automatic calibration of depth, probe type, left/right guides and angle up/down orientation
 - CFM window

SETTINGS

- Default settings related to the medical application and transducer for image quality optimization
- User settings memorized in the system as well as on a flash card

1.8.2 2D (B-Mode)

SCANNING SECTOR

- Angle: 40, 45, 60, 75, 90, 110 and 140° for Annular Sector (Probe dependent)
- Angle: 30, 45, 60, 75, 90 and 110° for Convex Array (Probe dependent)
- Depth: 2 cm to 24 cm, up to 10 depths (Probe dependent)
- Nominal frequency range: 2 to 14 MHz (Probe dependent)

FRAME RATE

- Up to 218 fps
- Depending on depth, angle and medical application

SIGNAL PROCESSING

- Large bandwidth: 1.5 - 18 MHz
- Overall Gain: 32 steps
- Time Gain Compensation: 5 sliders
- Dynamic focusing on reception
- Up to four focus zones on transmission
- Automatic adjustment of reception bandwidth for each depth
- Contour enhancement: 7 positions application dedicated
- Dynamic range control (reject): 4 positions to increase the contrast and reduce weak echoes
- Frame filter: 4 non linear smoothing filters + OFF position

- Automatic Frequency Adjustment (A.F.A.) for standard and less echogenic patient (Freq+/Freq-)
- Grey scale optimization thanks to 8 Gamma curves (probe dependent)
- Iris colour system

IMAGE PRESENTATION

- Single, Double and Quad image representation
- Freeze mode
- Left/right
- Up/Down
- Video inversion

RESOLUTION

- 512 x 512 pixels on screen for 2D image display
- 256 grey levels

IMAGE MEMORY

- Cine Mode: up to 282 images (probe and medical application dependent)

1.8.3 TM (M-Mode)

SIGNAL PROCESSING

- Same as 2D mode

IMAGING PARAMETERS

- Scrolling speed:
 - 2, 3, 5, 8 sec./screen (full screen)
 - 1, 1.5, 2.5, 4 sec./screen (2D + TM)

M LINE STEERING

- Trackball controlled over complete 2D sector

DISPLAY

- 2D (50% screen) + TM (50% screen)
- Full screen TM

IMAGE MEMORY

- Cine Mode:
 - up to 16 trace screens in full TM
 - up to 5 trace screens in 2D + TM

1.8.4 Spectral Doppler Mode

AVAILABLE MODES

- Steerable PW and CW
- Multi-frequency Doppler modes
- Spectral colorization
- Automatic 2D image update when adjusting Doppler cursor position

SIGNAL PROCESSING

- Doppler frequencies: 2, 3, 4 and 8 MHz (probe dependent)
- Velocity range:
 - PW: +/-1 kHz to +/- 10 kHz
 - CW: +/-1 kHz to +/- 20 kHz Doppler shift (PRF/2)
 - +/- 10 cm/sec. to +/- 3.5 m/s (PW), +/- 7.2 m/sec. (CW), full scale, depending on probe and operating frequency
- High pass wall filter: 10 cut-off frequencies adjustable between 50 to 1000 Hz
- Grey scale optimization with 8 post-processing curves (probe dependent)
- Spectrum gain control: 11 selections between 0 and 30 dB
- 120 dB dynamic range for best sensitivity
- 256 point FFT, computing time of 0.2 ms
- Doppler transmit power control: 8 selections between 0 dB and -21 dB
- Doppler angle correction: from -80 to 80 °
- Scrolling speed:
 - 2, 3, 5, 8 sec./screen (full screen)
 - 1, 1.5, 2.5, 4 sec./screen (2D + SP)
- Adjustable audio volume
- Iris colour system

PW GATE

- PW gate adjustable for sample volumes between 1 and 15 mm (8 selections)
- PW gate adjustable with the trackball between 0 and maxi depth of the image format

DISPLAY

- 2D (50% screen) + Doppler (50% screen)
- 2D icon + Doppler
- Base line shift: 9 positions for optimal signal display, avoiding spectrum aliasing
- V_{MEAN} real time trace display
- V_{MAX+} and V_{MAX-} real time trace display
- Quasi duplex automatic refresh: 4 levels, according to scrolling speed

IMAGE MEMORY

- Cine Mode:
 - up to 16 trace screens in full Doppler
 - up to 5 trace screens in 2D + Doppler

ACOUSTIC POWER OUTPUT

- Fulfills acoustic output display standard
- Complies with FDA acoustic output limits
- Automatic power output adjustment versus medical application for optimal Doppler performance (ALARA)
- User selectable Doppler transmit power attenuation: 8 positions between 0 and -21 dB

1.8.5 Colour Doppler Modes

MODES

- Steerable Color Flow Mapping (CFM) on electronic array probes
- Velocity, Variance and Power mode
- Automatic 2D/CFM image update when adjusting Doppler cursor position

SIGNAL PROCESSING

- Multi frequency CFM mode: 2.5, 3, 5 and 6 MHz (Probe dependent and user selectable)
- High pass wall filter: 6 cut-off frequencies adjustable between 44 to 4400 Hz (dependent on velocity range)
- Colour gain control: 32 positions between 0 and 20 dB
- 4 positions colour persistence
- Velocity Ranges: from ± 125 Hz to ± 7.5 kHz Doppler shift (PRF/2) or ± 1.6 cm/s to ± 2.8 m/s full scale, depending on probe, frequency and medical application

CFM WINDOW

- From 10% to full length of 2D sector, trackball controlled resize
- From 10% to full width of 2D sector, trackball controlled resize
- Trackball control of window position within 2D sector

DISPLAY

- Up to 128 colour shades, 8 levels of turbulence
- 8 user selectable colour maps for optimum rendering of either low velocities, high velocities and turbulence
- 9 positions of baseline shift
- Turbulence on/off
- Colour invert
- Chroma maps for optimum rendering of 2D echo structures
- Up to 64 frames cine memory

ACOUSTIC OUTPUT

- Fulfills acoustic output display standard
- Complies with FDA acoustic output limits
- Automatic power output adjustment versus medical application for optimal Doppler performance (ALARA)
- User selectable Doppler transmit power attenuation: 8 positions between 0 dB and - 21 dB

1.8.6 3D Imaging¹

2 highly intuitive user interface packages:

- 3D - Fetal View™ (2D reconstruction)
- 3D - Vascular View™ (2D and CFM reconstruction)
 - Quick and easy 3D acquisition

1. SIGMA 330 Excellence only

- Instantaneous multiplanar 3D reconstruction (MPR)
- 3D application specific rendering algorithms
- 3D segmentation tools (advanced filter operations)
- Image export to standard PC file format (.bmp and .avi)
- Digital archiving

1.8.7 Digital Archiving: KIPRISM

- Digital archiving on Memory Card:
 - up to 32 images on 4 megabytes memory card
 - up to 64 images on 8 megabytes memory card
- Transfer on Personal Computer via memory card (PCMCIA standard, DOS format)
 - Images in PCX format, report in TXT format
- Up to 15000 color images per archiving media (640 MB)
- DICOM 3.0 compatible (with PACS option)

1.8.8 ECG Module (option)

FORMATS

- for all single or dual screen formats

INPUT

- Isolated input, type CF, Defibrillator proof (IEC 601-1)
- through serial port, 240 x 8 bit / second, QRS trigger available
- ECG Gain: 1000 (1V / 1 mV)
- Heart rate: up to 180 bpm
- Recovery time after defibrillator shock: > 5 sec

B MODE TRIGGER

- in single and dual B mode available, trigger moment may be set by user.
- For dual pad modes two independent triggers can be set.

DISPLAY and CINE REVIEW

- Display trace (on video screen)
- Indication of time relationship between 2D mode image and ECG trace by marker on ECG trace. Cine review on trace modes is also available.

1.8.9 EasyPrint™

- Direct output to inkjet printer
- Compatible with HP PCL level III

1.8.10 USB-Link™

- Digital transfer of images and report text files to Personal Computer through USB cable.
- Compatibility: refer to Chapter 3.18.2, "Compatibility", on page 3-99.

1.8.11 Peripherals (Optional)

All the following peripherals can be connected to the system:

- VCR (VHS and S-VHS)
- B/W video printer
- Color video printer
- Parallel DeskJet printer (PC compatible) for images (EasyPrint™) and report printout
- B/W monitor
- Color monitor

1.8.12 Inputs/Outputs

- S-VHS/VHS (including audio) input/output for VCR connection, PAL/NTSC compatible, video playback automatically fed to the monitor
- Black & White video composite output for B/W video printer connection
- Double footswitch (Freeze / Print/Select image)
- Memory card connector (PCMCIA) dedicated to software upgrade, user setup storage and digital archiving (KIPRISM)
- RGB video output for external monitor and color video printer
- Parallel port for images and report printout
- Serial port for peripheral devices
- USB port for data transfer to PC

1.8.13 Measurement

CALIPERS

- Trackball controls the multiple callipers
- Complete measurement capabilities on frozen images
- **2D**: distance, surface and circumference of area, surface and circumference of ellipse, angle, volume; distance and area ratio
- **TM**: distance, time, slope, heart rate; distance and time ratio; LV studies
- **PW/CW**: speed gradient, frequency, time, acceleration, integral, PI & RI, RI, heart rate; speed, gradient and time ratio
- **CFM**: velocity, velocity profile and frequency
- Specific measurements for OB/GYN
- Up to 10 result lines on screen

ANNOTATIONS

- Annotation lists: user-defined
- Text, arrows, body markers

PATIENT REPORT

- Automatic selection of relevant measurement from patient report
- Comprehensive report for each medical application: Radio, Vasc., Ob/Gyn, Pediatrics, Cardio.

- **Peripheral vascular:** stenosis percentage, continuity equation, resistance index, stenosis index, pulsatility index, spectral broadening index, flow volume, frequency
- **Abdominal:** volume 1 to 4 (user-defined), cardiac output, diameter, continuity equation
- **Pediatric:** hip angles
- **Ob/Gyn:** extensive measurements capabilities including BPD, FML, CRL, BOD, ABD, THD, AC, GES, HC, OFD, APD, TAD, Foetal Weight, Estimated Birth Date
- **Cardio:** left ventricular volumetry using Simpson, area length single and bi-plane formulas, systolic and diastolic volume using Teichholz rule, shortening fraction, myocardial mass and mass index, left ventricular circumference, ejection fraction, cardiac output and index, stroke volume and index, mean velocity, pressure and mean pressure gradient, pressure half time and valve area, time to peak velocity in systole, right and left ventricular ejection time and pre-ejection period, right ventricular systolic pressure, continuity equation, QP/QS
- All applications: body surface area (BSA)

MEASUREMENT ACCURACY

Mode:	Parameters:	Typical accuracy:
2D	• Distance	• < +/- 3% • 1 mm, when 3% of the measured value is less than 1 mm
	• Angle	< +/- 2.5 °
TM	• Distance	• < +/- 1% • 0.5 mm, when 1% of the measured value is less than 0.5 mm
	• Time	< +/- 1%
	• Slope	< +/- 2%
SP	• Speed	< +/- 5% of max. displayed velocity
	• Frequency	< +/- 5% of max. displayed frequency
	• Gradient	< +/- 10%
	• Time	< +/- 1%
	• Acceleration	< 10%
CFM	• Velocity	< +/- 10% of the velocity range
	• Frequency	< +/- 10% of the frequency range
HR	• Heart rate computed by ECG	+/- 1 bpm

Table 1-6: Measurement Accuracy

1.8.14 Acoustic Power

The acoustic power depends on Medical Application.

- $I_{SPPA} < 190 \text{ W/cm}^2$ (Medical Application independent)
- $I_m < 310 \text{ W/cm}^2$ (Medical Application independent)

- I_{SPTA} In situ, in mW/cm^2 , is shown in the table below

MEDICAL APPLICATION	CARDIO	VASC.	RADIO, OB/GYN
I_{SPTA} In situ, in mW/cm^2	< 430	< 720	< 94

Table 1-7: Acoustic Intensity

- Accuracy of MI display: +/- 30 %
- Accuracy of TI display: +/- 50 %

1.8.15 Environment

TEMPERATURE

- Operating temperature: 10 °C to 40 °C (50 °F to 104 °F)
- Storage temperature: -20 °C to 40 °C (-4 °F to 104 °F)

HUMIDITY

- Operating humidity: 30% to 80%, non condensing
- Storage humidity: 30% to 95%, non condensing

ATMOSPHERIC PRESSURE

- Operating pressure: 700 mbar to 1060 mbar
- Storage pressure: 500 mbar to 1060 mbar

ELECTRICAL SPECIFICATIONS

- Input voltage: 100 - 127 and 200 - 240 V~
- Mains frequency: 50 - 60 Hz
- Consumption: 340VA (main unit only), 680 VA (with integrated cart and peripherals)

ELECTROMAGNETIC FIELD

- Maximum field strength without degradation of performance: 1 V/m

1.8.16 Regulation and Safety

- CE MDD mark
- German K.V. regulation
- IEC 601-1 Class 1 Type B (Electrical Safety)
- IEC 1157 (Acoustic power reporting)
- FDA 510 (k)

1.8.17 Dimensions

SIGMA 330 Master

- Height: 380 mm
- Width: 470 mm
- Depth: 526mm
- Weight: 29 kg

SIGMA 330 Expert

- Height: 1230 mm (min.) - 1305mm (max.)
- Width: 580 mm
- Depth: 684 mm
- Weight: 90 kg

SIGMA 330 Excellence

- Height: 1230 mm (min.) - 1305 mm (max.)
- Width: 580 mm
- Depth: 684 mm
- Weight: 103 kg

This page is intentionally left blank

2. INSTALLATION

2.1 Installation Requirements

Be sure that the site is sufficiently ventilated and do not install the instrument near any important heat source.

In order to prevent an overheating, ensure that the ventilation openings are not covered and keep the rear panel away from a vertical wall.

Bring the package relief as close as possible to the required operating location.

It is recommended to provide two people for removing SIGMA 110/330 from its package.

2.2 Unpacking

2.2.1 Warning

Installation must be performed by authorized KONTRON MEDICAL SAS personnel. Any attempt by unauthorized personnel to install the instrument may invalidate the KONTRON MEDICAL SAS warranty.

If the instrument is received in damaged conditions, request an immediate inspection by the carrier and local KONTRON MEDICAL representative.

2.2.2 Unpacking the Instrument

SIGMA 110 and SIGMA 330 instruments are packed in non-returnable packings.

2.2.2.1 SIGMA 110 Light/Master and SIGMA 330 Master

These models are packed in a cardboard box. Remove it carefully.

2.2.2.2 SIGMA 330 Expert and SIGMA 330 Excellence

The upper part (Monitor) is packed in a cardboard box. Remove it carefully.

For SIGMA 330 Excellence, the flat screen and micro-computer are packed in a separate cardboard box. Remove them carefully.

The instrument body (Cart) is packed into a wood crate:

- Remove the top and side boards.
- Remove the foam protecting the instrument.
- Remove the instrument from the pallet.

2.3 Checking the Instruments Identification

The identification label with designation, reference number and serial number is affixed to the rear panel (see figure 1-10, "SIGMA 330 Expert rear panel", on page 1-23, figure 1-11, "SIGMA 330 Excellence rear panel", on page 1-25 and figure 1-12, "SIGMA 110 Light, Master and SIGMA 330 Master rear panel", on page 1-26).

2.4 Checking the Delivery

Check the contents of the consignment with the delivery note that is supplied with each system. If parts are missing or damaged, inform your local KONTRON MEDICAL representative.

Following standard parts are supplied with the instrument.

For ordering optional accessories, refer to Chapter 6.3, "Accessories", on page 6-5.

Qty.	Ref.	Designation
1	100 250	250 ml bottle of ultrasound gel
1	411 353	Power cable (EURO/D CEE 22)
1 (or)	487 848	Power cable "North American Hospital Grade" (for US)
1	485 055	Memory card 4 MB (PCMCIA) for SIGMA 110 Light and Master
1	477 729	Memory card 4 MB - SRAM (PCMCIA) for SIGMA 330 Master
1	484 164	Memory card label
1	DOC31001EN	Operator Manual - English (according to system language)
1	462 489	Medical Ultrasound Safety Guide (for US only)
1 (or)	DOC31001FR	Operator Manual - French (according to system language)
1 (or)	DOC31001GE	Operator Manual - German (according to system language)
1 (or)	DOC31001IT	Operator Manual - Italian (according to system language)
1 (or)	DOC31001SP	Operator Manual - Spanish (according to system language)
1 (or)	DOC31001CY	Operator Manual - Russian (Cyrillic, according to system language)
1	483 184	Remote control Unit - English (according to system language) ^a
1 (or)	483 176	Remote control Unit - French (according to system language) ^a
1 (or)	483 168	Remote control Unit - German (according to system language) ^a
1 (or)	483 141	Remote control Unit - Italian (according to system language) ^a
1 (or)	483 133	Remote control Unit - Spanish (according to system language) ^a
1 (or)	483 125	Remote control Unit - Cyrillic (according to system language) ^a
2	524 204	Fuse, 5 x 20 mm, T 2 A
2	717 150	Fuse, 5 x 20 mm, T 4 A (according to line voltage)
1	487 090	Notice for NTSC fuses
1	481 033	Remote control cable for Video printer
1	862 169	Coaxial cable (75, BNC/BNC, L = 2 m)
1	487 163	USB cable (A/BM/M 15 Pts, L = 1.8 m) ^b
2	471 059	Air filter
1	426 016	Quality Control form

Table 2-1: Supplying list for SIGMA 110 Light/Master and SIGMA 330 Master

a. only for SIGMA 330 Master

b. when USB-Link™ option is installed

Qty.	Ref.	Designation
1	100 250	250 ml bottle of ultrasound gel
1	411 353	Power cable (EURO/D CEE 22)
1 (or)	487 848	Power cable "North American Hospital Grade" (for US)
1	477 729	Memory card 4 MB - SRAM (PCMCIA)
1	484 164	Memory card label
1	DOC31001EN	Operator Manual - English (according to system language)
1	462 489	Medical Ultrasound Safety Guide (for US only)
1 (or)	DOC31001FR	Operator Manual - French (according to system language)
1 (or)	DOC31001GE	Operator Manual - German (according to system language)
1 (or)	DOC31001IT	Operator Manual - Italian (according to system language)
1 (or)	DOC31001SP	Operator Manual - Spanish (according to system language)
1 (or)	DOC31001CY	Operator Manual - Russian (Cyrillic, according to system language)
1	483 184	Remote control Unit - English (according to system language)
1 (or)	483 176	Remote control Unit - French (according to system language)
1 (or)	483 168	Remote control Unit - German (according to system language)
1 (or)	483 141	Remote control Unit - Italian (according to system language)
1 (or)	483 133	Remote control Unit - Spanish (according to system language)
1 (or)	483 125	Remote control Unit - Cyrillic (according to system language)
2	524 204	Fuse, 5 x 20 mm, T 2 A
2 (or)	717 150	Fuse, 5 x 20 mm, T 4 A (according to line voltage)
2	528 129	Fuse, 5 x 20 mm, T 6.3 A
2	503 126	Fuse, 5 x 20 mm, T 8 A (according to line voltage)
2	481 033	Remote control cable for Video printer
1	862 169	Coaxial cable (75, BNC/BNC, L = 2 m)
1	481 076	VCR cable ^a
1	481 068	Footswitch
1 (or)	487 082E	Integrated PC without frame-grabber board ^b
1	487 082OE	Integrated PC with frame-grabber board ^c
1	487 341	External PC Monitor ^{b,c}
1	487 163	USB cable (A/BM/M 15 Pts, L = 1.8 m) ^{b,c,d}
1	485 519	SIGMA/ORION VIDEO Cable ^c
1	487 376	PC Keyboard, QWERTY 86 Keys ^{b,c}
3	487 309	Keyboard Label "CTRL-ALT-ALTGR" ^{b,c}
3	487 368	Keyboard Label "CAPS-DEL" ^{b,c}
1	487 724	Allen key N°6 ^{b,c}
1	410 713	CEE22 socket male 2x10A + T ^{b,c}
2	471 059	Air filter
1	426 016	Quality Control form

Table 2-2: Supplying list for SIGMA330 Expert and SIGMA 330 Excellence

- a. when CFM option is installed on SIGMA 330 systems
- b. for SIGMA 330 Excellence without frame-grabber board
- c. for SIGMA 330 Excellence with frame-grabber board
- d. when USB-Link™ option is installed

2.5 Transport

- For transport, SIGMA 110 and SIGMA 330 equipments must be placed in their original package provided at their delivery.
- Peripherals must be placed in their original package provided at their delivery.
- Before carrying the SIGMA 330 Expert or SIGMA 330 Excellence unit, follow these instructions:
 1. Disassemble the upper part (Monitor) which is attached on the top of the cart.
 2. Remove the flat screen attached on the side of SIGMA 330 Excellence.
 3. Remove the integrated computer from SIGMA 330 Excellence

2.6 Installation of SIGMA 330 Expert and SIGMA 330 Excellence

2.6.1 Installation of the integrated cart

After unpacking, to assemble the SIGMA 330 Expert or SIGMA 330 Excellence unit:

- place the upper part on the cart
- connect the following cables :
 1. Reference 412 139: power cable (labelling: ECHOGRAPHE)
 2. Reference 411 353: mains cable
 3. Reference 481 068: FootswitchFor connecting the other cables, see Chapter 2.9, “Connection of Peripherals”, on page 2-15.
- fasten the two milled screws **①** inside the cabinet dedicated to VCR (Front view), see figure 2-1, “Installation of SIGMA 330 Expert or SIGMA 330 Excellence”, on page 2-7

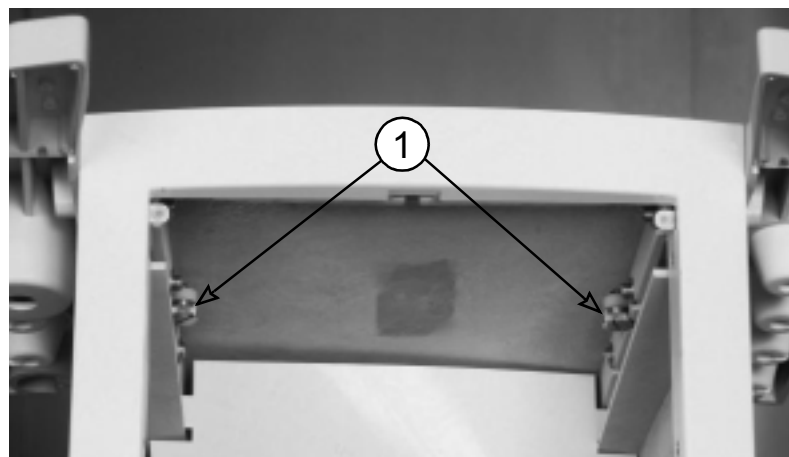
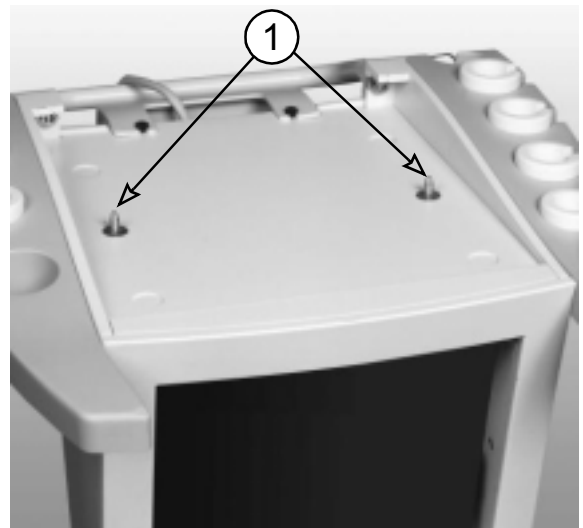
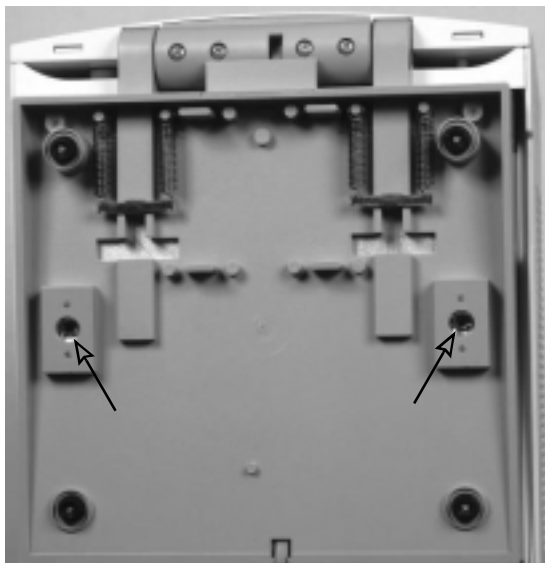

Figure 2-1: Installation of SIGMA 330 Expert or SIGMA 330 Excellence

2.6.2 Installation of the flat panel monitor

After unpacking, to assemble the monitor on the unit:

- place the monitor on its holder and tighten the screw ①.
- make firm the cables with both cable fasteners ②.
- connect the following cables:
 1. Reference 487155: VGA monitor cable (for SIGMA 330 Excellence) ③
Reference 485659: signal monitor cable (for SIGMA 330 Expert)
 2. DC power cable ④

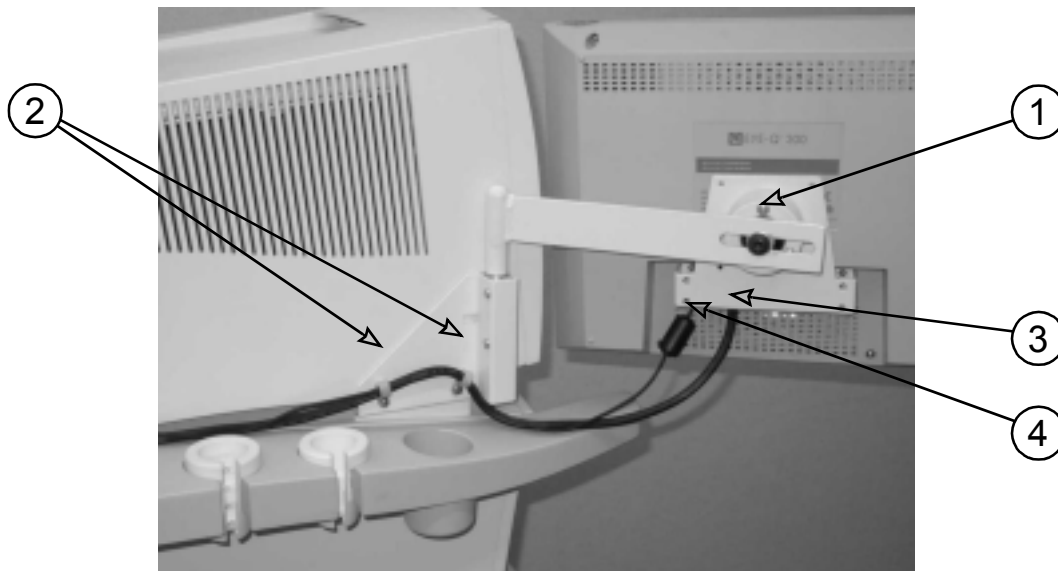

Figure 2-2: Installation of the flat panel monitor

2.6.3 Installation of the integrated compact PC (SIGMA 330 Excellence only)

After unpacking, to assemble the PC into the cart:

- Mount both supports on the right and left side of the PC; use the M5x6 screws mounted on the PC
- Remove the lower panel from the lower compartment of the cart with screwdriver Pozidriv N°6
- Place the PC in the lower compartment and connect the following cables (see figure 2-3, "Integrated PC (rear panel)", on page 2-9):
 1. Reference 487163: USB cable between PC and USB connector of SIGMA 330 Excellence. ①
 2. Reference 487163: USB cable between PC and your USB Hub or your USB peripheral (if any) ②
 3. Reference 485519: Matrox Orion Video cable between PC and "COLOR PR/MONITOR" connector of SIGMA 330 Excellence (only necessary for the 487082OE PC) ③
 4. Reference 487155: VGA Monitor Cable between PC and Flat 15" Monitor: ④ for the 487082E PC and ⑤ for the 487082OE PC.
 5. AC power cable to PC ⑥

6. Reference 487775: DC power cable to Monitor ⑦
 7. Ethernet Network cable (if necessary) ⑧
 8. FireWire (IEEE-1394) cable to FireWire magneto-optical disk drive ⑨
 9. Reference 488364: AC power cable to FireWire magneto-optical disk drive ⑩
- Connect the small PS/2 PC keyboard to the PC ⑪
 - Push the PC at the bottom of the compartment (see figure 2-4)
 - Wind up the panel again (see figure 2-4)

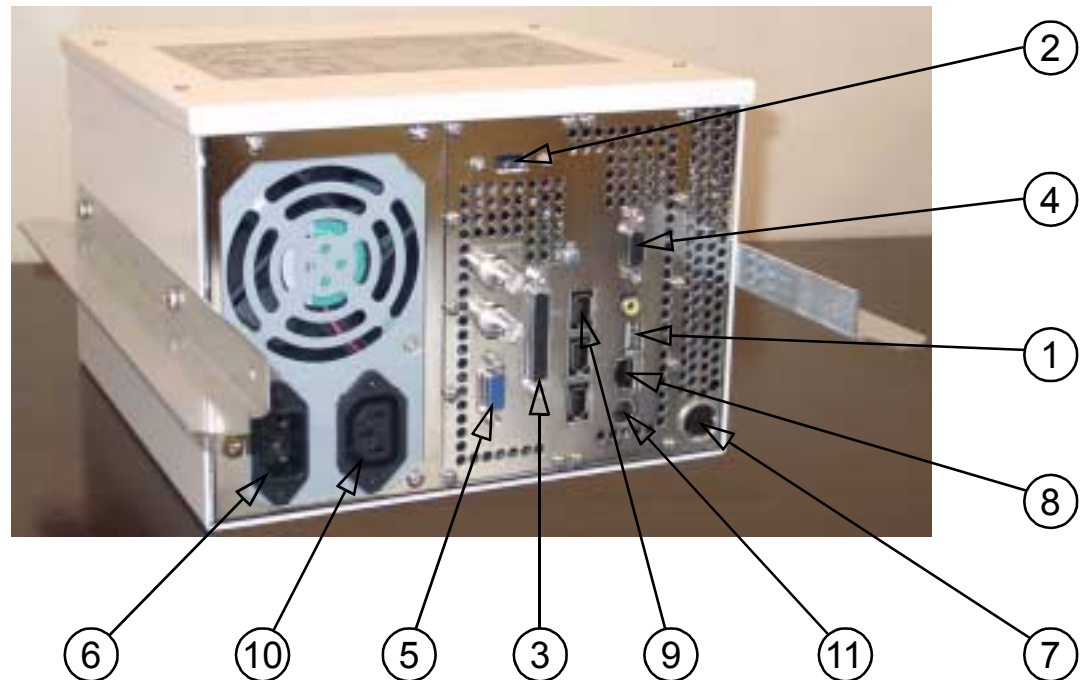

Figure 2-3: Integrated PC (rear panel)



Figure 2-4: Integrated PC (front view mounted in the cart)

2.7 Power Source Connection

2.7.1 Input Power Source

The SIGMA 110 and SIGMA 330 instruments are designed to operate on single phase line supply.

The unit is automatically grounded via the power cable, provided a 3 pin wall socket with a grounded third pin is used.

2.7.1.1 SIGMA 110 Light/Master and SIGMA 330 Master

MAINS VOLTAGE	FUSES	
	Rating	Type
100 - 127 V ~	T 4 A	5 x 20 mm
200 - 240 V ~	T 2 A	5 x 20 mm

Table 2-3: Line voltage/Fuses rating for SIGMA 110 Light/Master and SIGMA 330 Master

RATED INPUT POWER	RATED FREQUENCY
340 VA / 100 - 127 V ~	50 & 60 Hz
340 VA / 200 - 240 V ~	50 & 60 Hz

Table 2-4: Power/Frequency rating for SIGMA 110 Light/Master and SIGMA 330 Master

Check that the selected voltage range corresponds to local power line voltage.

See figure 1-12, "SIGMA 110 Light, Master and SIGMA 330 Master rear panel", on page 1-26 to locate fuses.

2.7.1.2 SIGMA 330 Expert and SIGMA 330 Excellence

MAINS VOLTAGE	FUSES		
	Rating		Type
	Top	Bottom	
100 - 127 V ~	T 4 A	T 8 A	5 x 20 mm
200 - 240 V ~	T 2 A	T 6.3 A	5 x 20 mm

Table 2-5: Power/Frequency rating for SIGMA 330 Expert/Excellence

RATED INPUT POWER	RATED FREQUENCY
680 VA / 110 - 127 V ~	50 & 60 Hz
680 VA / 200 - 240 V ~	50 & 60 Hz

Table 2-6: Power/Frequency rating for SIGMA 330 Expert/Excellence

The "top" fuses, located at the top part of the instrument are dedicated to electronic cabinet.
 The "bottom" fuses, located at the bottom are dedicated to the complete SIGMA 330 Expert and SIGMA 330 Excellence power supply including electronic cabinet and power output for peripherals.

See figure 1-10, "SIGMA 330 Expert rear panel", on page 1-23 to locate fuses.

2.7.2 Output Power Source

SIGMA 330 Expert and SIGMA 330 Excellence include three auxiliary mains outlets to supply some peripheral units, such as VCR, Printers and other peripherals, plus another one to supply the Electronic Cabinet. (See Chapter III.2.1, "Electrical Safety", on page -xix)

Power voltage supplied by the auxiliary mains is the same as local power line.
 Before connecting a peripheral to the SIGMA 330 power output, be sure that its voltage range corresponds to the local power line voltage and its consumption fits with the output rating for peripherals.

MAINS VOLTAGE	MAX. CONTINUOUS OUTPUT RATING for PERIPHERALS
100 - 127 / 200 - 240 V ~	340 VA

Table 2-7: Output Voltage/Power rating

CAUTION

When the SIGMA 330 System includes more than three peripherals (or must provide more than 340 VA), the additional peripherals must be supplied through a medical grade isolating transformer. Never connect them directly to wall outlets.

(See Chapter III.2.1, "Electrical Safety", on page -xix)

2.8 Connecting a Probe

2.8.1 SIGMA 330 Expert and SIGMA 330 Excellence Probe Assignment

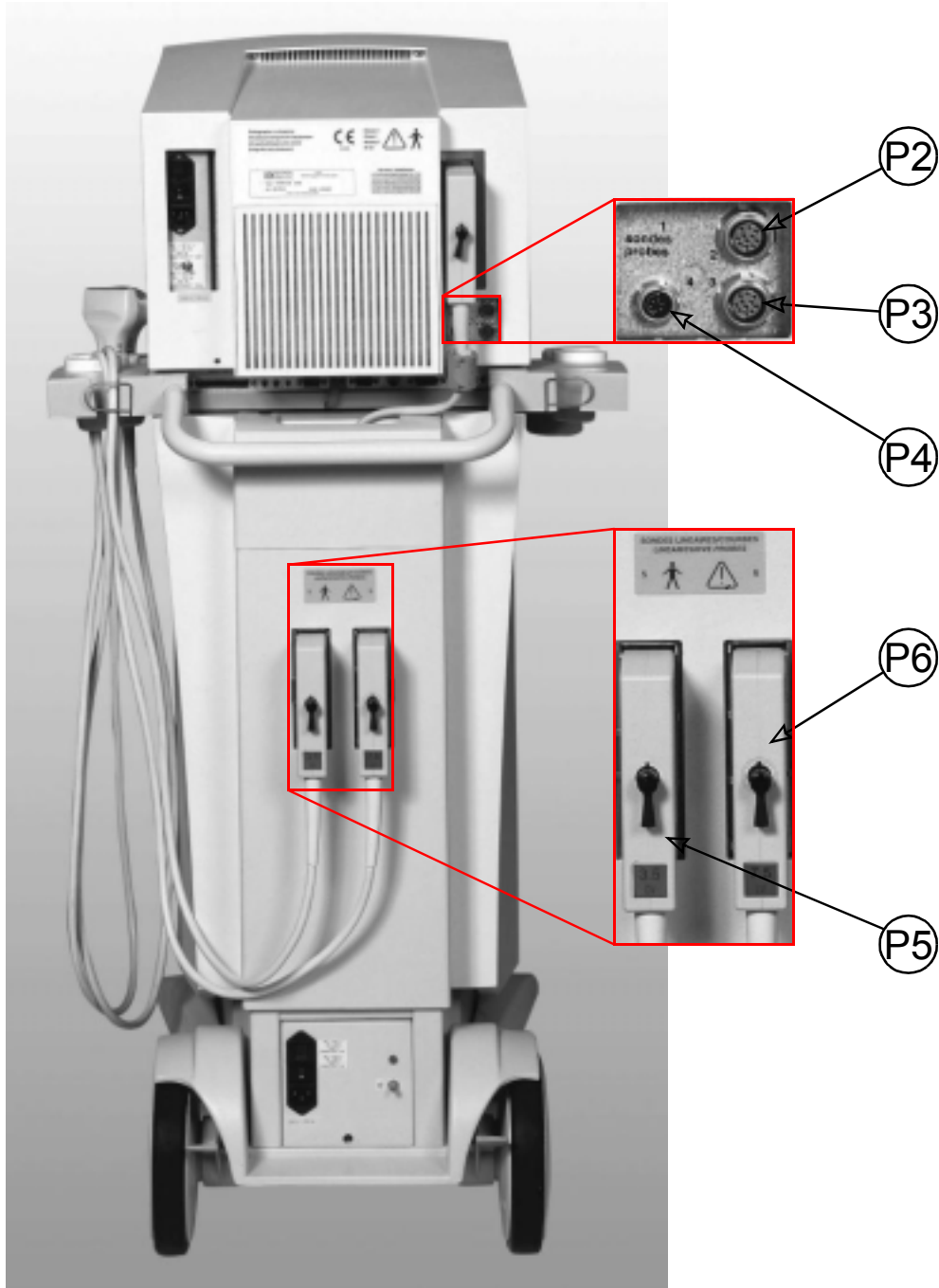

Figure 2-5: SIGMA 330 Expert/Excellence probe assignment

Both "P-2" and "P-3" ports, dedicated to Annular Sectorial probes (AS), the "P-4" port to Doppler pencil probes and the "P-5" and "P-6" ports to Linear/Convex probes, are assigned in the probe menu as shown in figure 2-5, "SIGMA 330 Expert/Excellence probe assignment", on page 2-12 and in Chapter 3.5.2.2, "Probe Main Menu, with Two Linear Probes", on page 3-12.

2.8.2 SIGMA 110 Light/Master and SIGMA 330 Master Probe Assignment

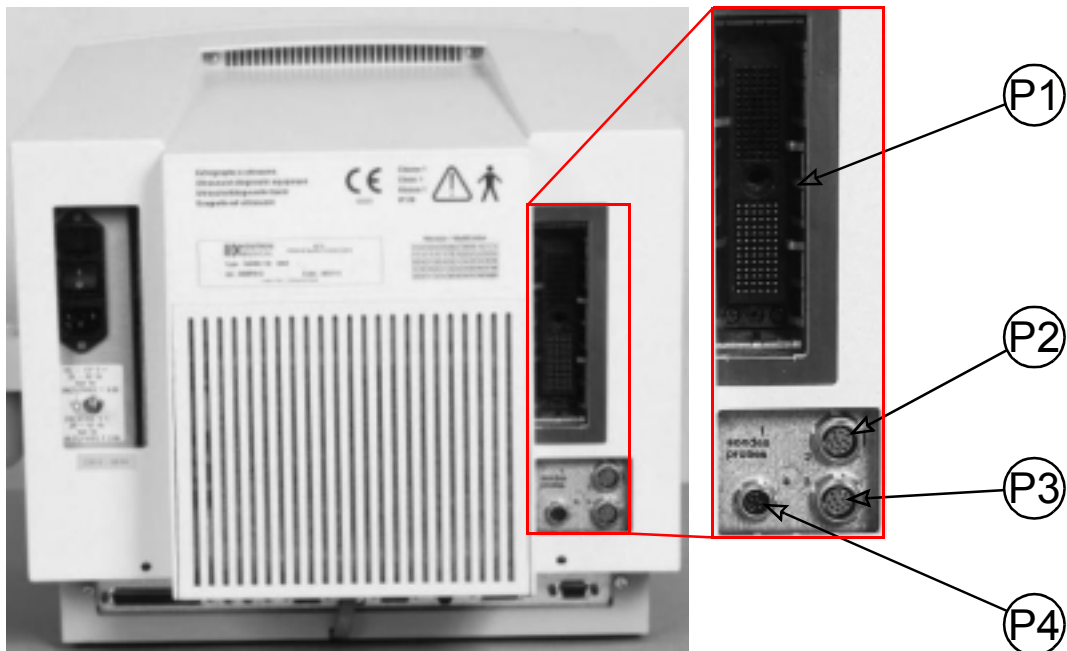

Figure 2-6: SIGMA 110 Light/Master and SIGMA 330 Master probe assignment

The "P-1" port, dedicated to Linear/Convex probes, both "P-2" and "P-3" ports to Annular Sectorial probes (AS) and the "P-4" port to Doppler pencil probes are assigned in the probe menu as shown in figure 2-6, "SIGMA 110 Light/Master and SIGMA 330 Master probe assignment", on page 2-13 and in Chapter 3.5.2.1, "Probe Main Menu, with One Linear Probe", on page 3-12.

2.8.3 Probe Connection

To connect or change a LINEAR/CURVE PROBE, insert the probe connector, cable side down, into the probe socket. Rotate the connector lock handle 1/4 turn clockwise to lock the connector in place.

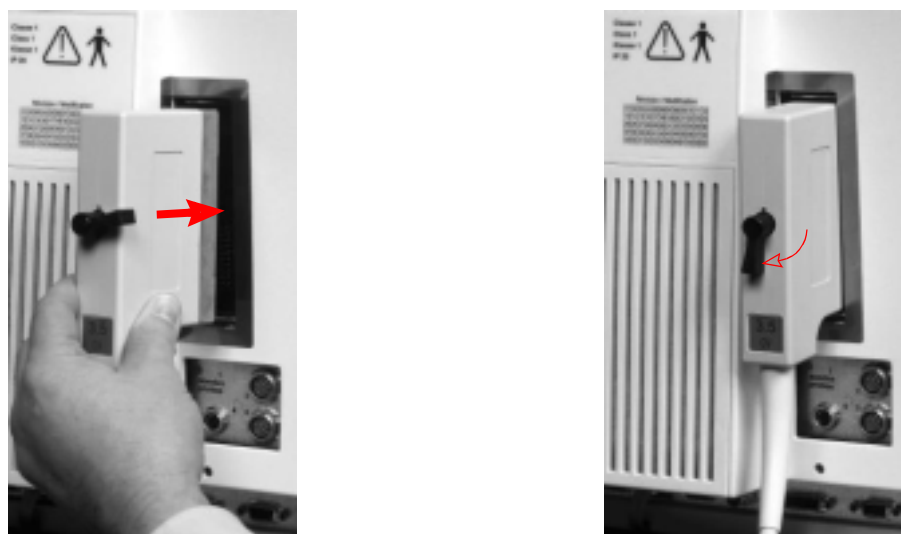

Figure 2-7: Connecting a Linear/Curve Probe

To disconnect probe, rotate the lock handle 1/4 turn counter clockwise and pull the probe connector away from the socket.



Figure 2-8: Disconnecting a Linear/Curve Probe

To connect a SECTOR/PENCIL PROBE, align the red point side up and push the probe connector in the socket.



Figure 2-9: Connecting a Mechanical Probe

! **Never connect or disconnect probe in live mode. When system operates in live mode, press the FREEZE key before connecting or disconnecting probe.**

2.9 Connection of Peripherals

2.9.1 Electrical safety with peripherals

The peripherals should be marked with CE identification mark and be in compliance with IEC 950 or IEC 601-1 Standards.

2.9.1.1 SIGMA 330 Excellence

- All equipments (printers, video recorders, external TV monitors and other peripherals) should be connected to the three isolated outputs provided by the system or powered through a medical grade isolating transformer when the system includes more than three peripherals or their total consumption exceeds 340 VA.

 **Never connect additional peripherals directly to wall outlets; use the outlet available in the cart or a medical grade isolating transformer which must comply with IEC 601-1 specifications. Wrong connections may compromise the electrical safety of the system. KONTRON MEDICAL provides a medical grade isolating transformer on request, see Chapter 6.3, *Accessories*, on page 6-5 for ordering.**

- RJ -45 Network Isolator must be used for connecting the system to network.

 **Never connect Network (RJ-45) directly to the system; use a medical grade network isolator which must comply with IEC 601-1 specifications. Wrong connections may compromise the electrical safety of the system. KONTRON MEDICAL provides a medical grade isolator on request, see Chapter 6.3, *Accessories*, on page 6-5 for ordering.**

2.9.1.2 SIGMA 330 Expert

- All equipments (printers, video recorders, external TV monitors and other peripherals) should be connected to the three isolated outputs provided by the system or powered through a medical grade isolating transformer when the system includes more than three peripherals or their total consumption exceeds 340 VA.

 **Never connect additional peripherals directly to wall outlets; use the outlet available in the cart or a medical grade isolating transformer which must comply with IEC 601-1 specifications. Wrong connections may compromise the electrical safety of the system. KONTRON MEDICAL provides a medical grade isolating transformer on request, see Chapter 6.3, *Accessories*, on page 6-5 for ordering.**

2.9.1.3 SIGMA 110 Light/Master and SIGMA 330 Master

- All equipments (printers, video recorders, external TV monitors and other peripherals) should be powered through a medical grade isolating transformer or connected via appropriate isolating accessories.

KONTRON MEDICAL provides the following isolating devices on request:

Peripheral/Option	Dedicated isolator/Isolating transformer
B&W video Printer	BNC Video Isolation Amplifier (ref. 488550)
Colour Video Printer	Isolation Transformer
VCR	S-Video Isolator (ref. 488542)
Parallel printer/ EasyPrint™	Printer Port Isolator (ref. 489859)
Colour repetition monitor	Isolation Transformer
Colour flat panel repetition monitor	S-Video Isolator (ref. 488542)
USB-Link™	Isolation Transformer

- When no dedicated isolating accessory is available, the Isolation Transformer must be used.
- KONTRON MEDICAL provides a medical grade isolating transformer and isolating accessories on request, see Chapter 6.3, “Accessories”, on page 6-5 for ordering.
 - Maximum power of Isolation Transformer is 750 VA. Sum of power of the different peripherals connected to the Isolation Transformer must be less than 475 VA (ultrasound system requires less than 275 VA).
 - Isolation Transformer is recommended when two or more isolators are required for cost and cabling reasons.

 **Never connect additional peripherals directly to wall outlets if no medical grade isolating device provides a galvanic isolation between the peripheral and the ultrasound system. Use a medical grade isolating transformer which must comply with IEC 601-1 specifications. Wrong connections may compromise the electrical safety of the system.**

(See also, Chapter III.2.1, “Electrical Safety”, on page -xix)

It is recommended to turn the system OFF before connecting any peripheral.

2.9.2 Recommended Peripherals

The following peripherals are recommended for use in SIGMA 110/330 Systems:

- **Black & white Video Printer**
 - MITSUBISHI P91E
 - SONY UP890MD
 - SONY UP895MD
- **Colour Video Printer**
 - MITSUBISHI CP700E
 - SONY UP-2300
- **S-VHS Video Cassette Recorders**
 - PANASONIC SVHS AG MD830E (PAL 220 V)
 - PANASONIC SVHS AG MD830 (NTSC 110 V)
 - SONY SVO-9500MDP
- **Parallel Printer**

Parallel printer compatible with PCL level III language:

 - HEWLETT PACKARD Deskjet 930C
 - HEWLETT PACKARD Deskjet 970Cxi
 - HEWLETT PACKARD Deskjet 990Cxi
- **External colour Monitor**
 - Eye Q 300M, flat 15" TFT colour monitor
 - CABEL C34N48X15H90A
 - SONY PVM-14M2MD or equivalent

A standard B & W VCR (PAL or NTSC) and an external standard B & W monitor (PAL or NTSC) can be connected to the SIGMA 330 and SIGMA 110 systems.

For using any other peripherals than those above mentioned, please contact your local service. To get more information for using these peripherals, consult their proper user's manual.

2.9.3 Archiving on Personal Computer

Archiving of digitized ultrasound images can be performed from SIGMA 110/SIGMA 330 systems to Personal Computer via PCMCIA Memory Cards.

- **PCMCIA reader**

The recommended PCMCIA reader for PC is: SCM MICROSYSTEMS SWAPBOX SBI-D2P

2.9.4 Connection of B&W Video Printer

The black & white video printer must be connected to B/W output of the SIGMA 110/SIGMA 330. This configuration is recommended for the MITSUBISHI P91 Black & White video printer:

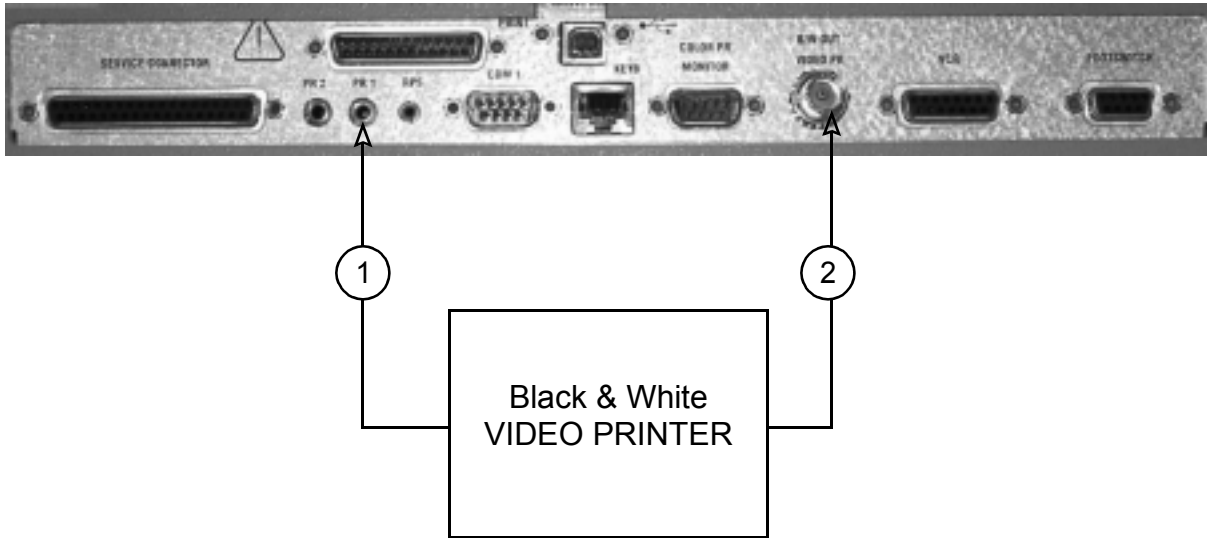

Figure 2-10: B & W Video Printer Connection

1. Reference 481 033: Remote control cable for Video Printer
2. Reference 862 169: Signal cable for Video Printer

For optimizing the printout image quality, set the DIP SWITCH and the control panel configuration on P91 video printer:

DIP SWITCH:		CONTROL PANEL:	
IMP	: 75 Ohms	BRT	: 0
	: HIGH (when ext. monitor)	CONT	: 5
N-TRAP	: OFF	Gamma	: 1
P-TRAP	: OFF	Print size	: SC ^a
IMAGE	: POSI		
AFC	: OFF		
DIR	: REV ^b		
MEMORY	: FRAME		
SCAN	: UNDER (NTSC)		
	: OVER (PAL)		
SAVING	: OFF		
PAPER	: HD ^c		

- a. SC setting is the largest print format.
- b. REV is for printing the first image on top of a paper stream.
- c. For best print results use only K65HM paper.

2.9.5 Connection of Colour Video Printer

The colour video printer must be connected to the colour video output of the SIGMA 330 systems. This configuration is recommended for the MITSUBISHI CP700E colour video printer:

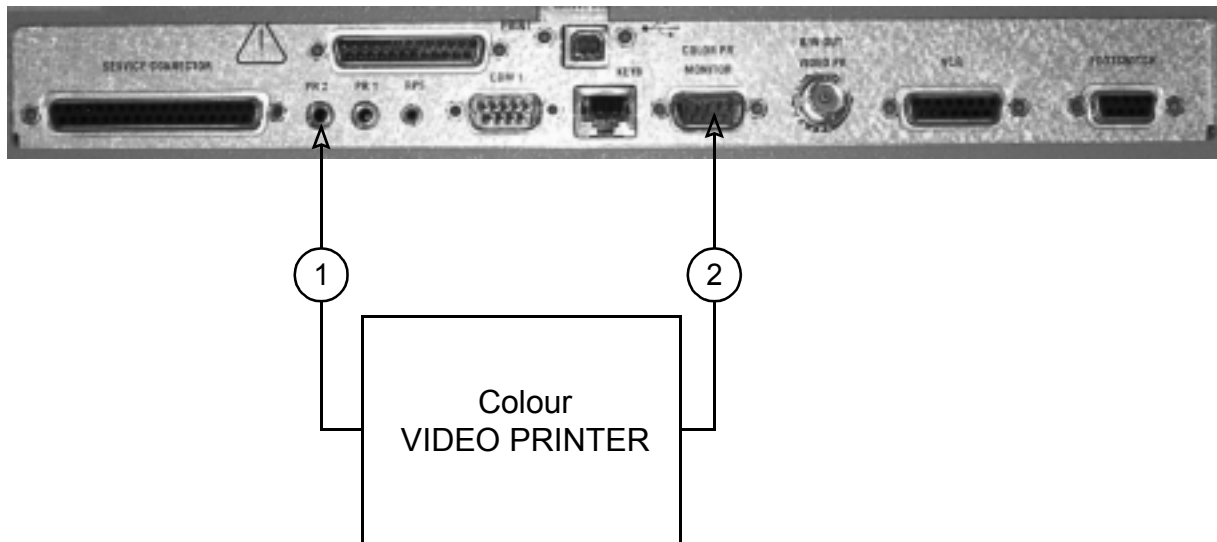

Figure 2-11: Colour Video Printer Connection

1. Reference 481 033: Remote control cable for Colour Video Printer
2. Reference 479 764: Signal cable for Colour Video Printer

2.9.6 Video Recorder (VCR)

SIGMA 110 and SIGMA 330 systems include a Super-VHS interface which allows the user to perform high quality record with S-VHS system. Any PAL or NTSC compatible VCR's can be connected to SIGMA 110 and SIGMA 330.

The VCR output can be configured at the factory to either S-VHS or VHS standard.

2.9.6.1 S-VHS VCR

The system features one VCR socket for S-VHS video input and output with sound.

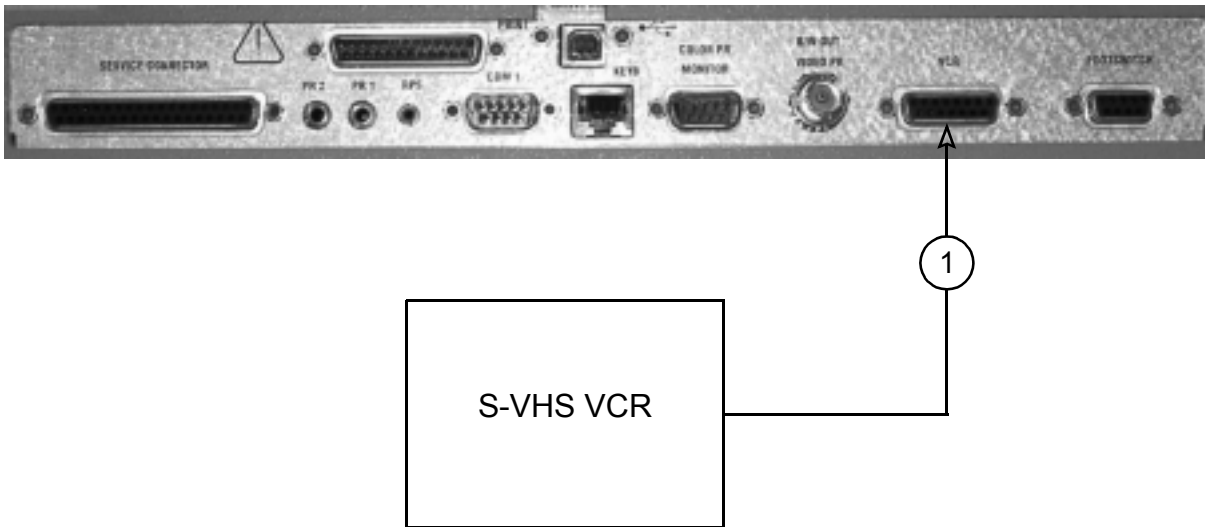

Figure 2-12: Connection of "S-VHS" VCR

1. Reference 481 076: integrated signal cable for S-VHS VCR

The recommended "S-VHS" VCR is PANASONIC AG-MD830E.

This recorder includes a "S-VHS AUTO/OFF" selector on its front panel. Set this selector AUTO for S-VHS operation.

To obtain the best performances use Super VHS Video Cassettes. The switch "MODE LOCK" have to be set to "OFF". The switch "Hi-Fi/NORM" must be set to "Hi-Fi".

2.9.6.2 VHS VCR

The system features one VCR socket for VHS video input and output with sound.

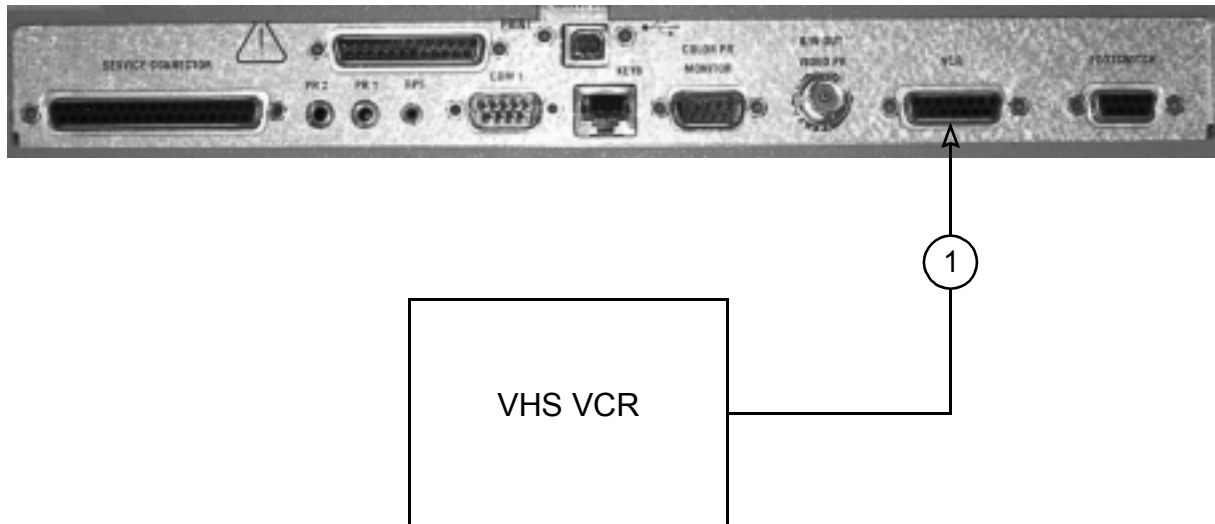

Figure 2-13: Connection of "VHS" VCR

1. Reference 487 252: integrated signal cable for VHS VCR

2.9.6.3 Black & White VHS VCR

A Black & White VHS VCR can be connected to S-VHS VCR output using an adapter:

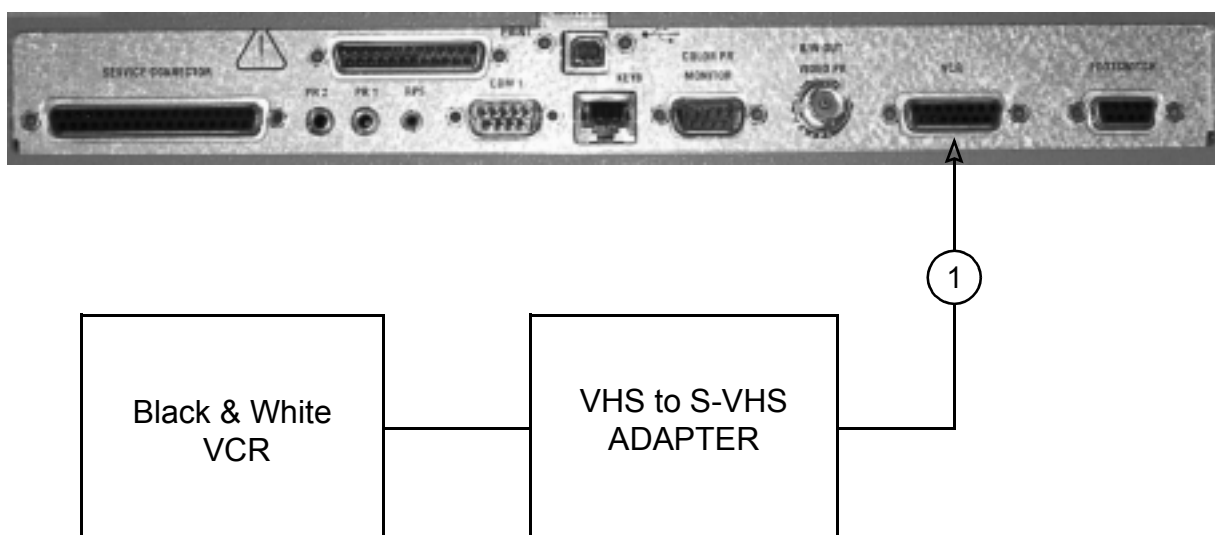

Figure 2-14: Connection of "VHS" VCR on S-VHS output

1. Reference 481 076: integrated signal cable for SVHS VCR
2. Reference 468 434: VHS to S-VHS adapter

2.9.7 ECG Module

The optional ECG Module can be coupled to SIGMA 110 and SIGMA 330 systems via the COM1 port located on the rear connector panel.

The ECG Module includes an ECG signal amplifier for displaying the trace on the video screen and a QRS detector for synchronizing the 2D image.

The ECG Module is not intended for electrocardiography or monitoring use.

Nevertheless, its isolated input is protected against the effects of a defibrillator and classified as "Type CF".

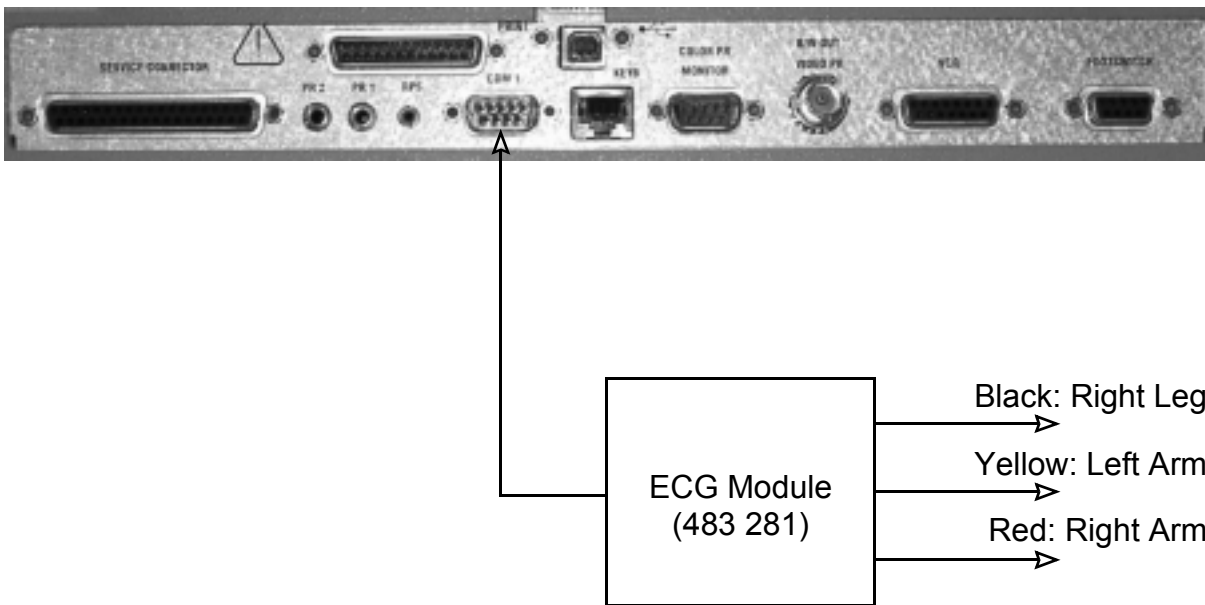

Figure 2-15: Connection of ECG Module

The figure 2-15 shows the connection of the ECG Module to SIGMA 110/330.

The patient cable must be connected to the patients right arm (Red), left arm (Yellow) and right leg (Black) by means of the included ECG electrode clamps or by clipping it to disposable ECG electrodes.

2.9.8 Colour Monitors

2.9.8.1 Connection of Colour Monitors

SIGMA 330 features an output port dedicated for an additional video monitor.

The following configurations are shown in figure for recommended colour monitors.

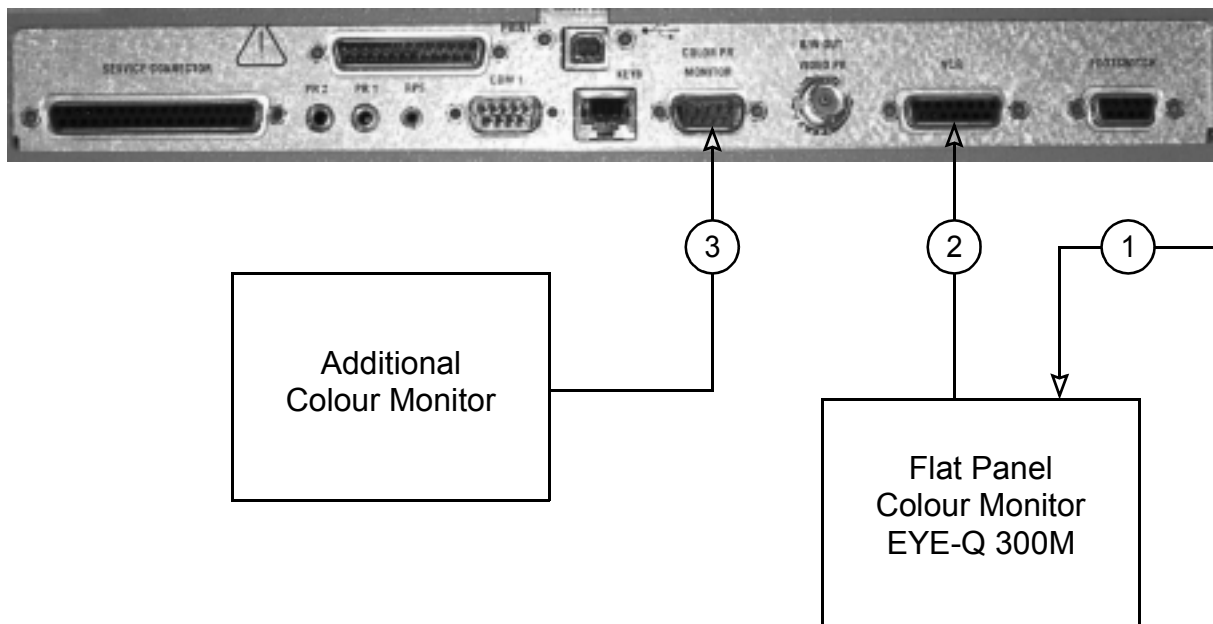

Figure 2-16: Connection of additional Colour Monitor

1. DC power Input (12 V) for EYE-Q 300M
2. Reference 485 659: signal cable for EYE-Q 300M
3. Reference 485 861: signal cable for CABEL
Reference 479 764: signal cable for SONY PVM-14M2MD or equivalent

2.9.8.2 Settings for Flat Panel Monitor EYE-Q 300M

For optimizing the image quality, the following settings are recommended and set in factory:

OSD Settings		EYE-Q 300M (VGA/S-VHS Settings)
Luminosity	Contrast	68
	Back Light	7
	Brightness	95
Size	Mode	variable
Colour Coordinates	Red	51
	Green	56
	Blue	57
Colour Resolution		High
Video Mode	INTL	Yes
	VTR	VTR
	IN3	S-Video
Colour Control	Saturation	50
	Hue	55

Table 2-8: Settings for Flat Panel Monitor EYE-Q 300M

The Luminosity setting (Contrast, Back Light and Brightness) should be set by the user, in accordance with environmental conditions.

In the Setting Mode (OSD = On Screen Display) the settings can be made using the operating keys ①.



Figure 2-17: Colour Monitor EYE-Q300M

2.9.9 Black & White Monitor

SIGMA 110 and SIGMA 330 feature output port dedicated for an additional video monitor.

Use only 75 Ohm (**not** 50 Ohm) coaxial cables to connect the external monitor.

If the monitor includes UNDERSCAN/OVERSCAN option, choose OVERSCAN for PAL standard and UNDERSCAN for NTSC.

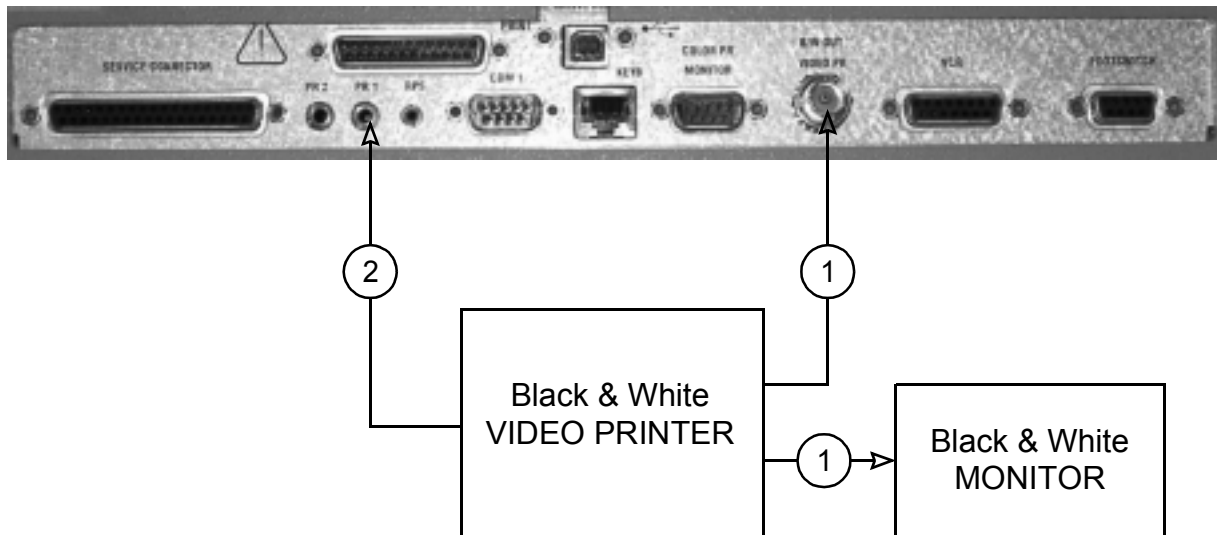

Figure 2-18: Connection of B & W monitor with Video Printer

1. Reference 862 169: Signal cable for Monitor and Video Printer (BNC/BNC, 75 Ohm)
2. Reference 481 033: Remote control cable for Video Printer/ECG

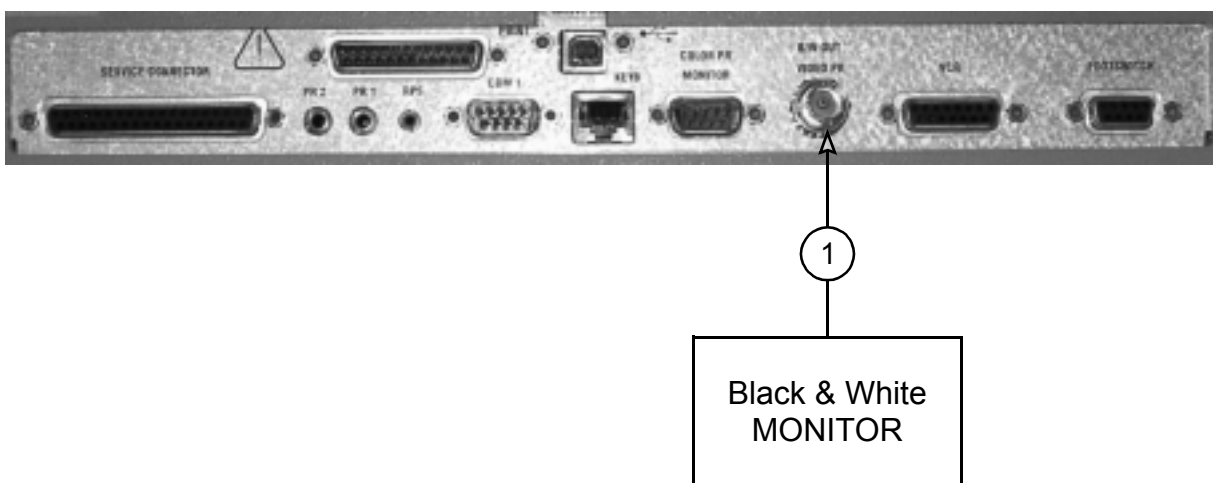

Figure 2-19: Connection of B & W monitor

1. Reference 862 169: Signal cable for Monitor (BNC/BNC, 75Ohm)

2.9.10 Printer

An optional Parallel Printer can be coupled to SIGMA 110 and SIGMA 330 systems via PRINTER output located on the rear connector panel.

It is recommended to use a standard cable ① (length should not exceed 2 meters).

The printer must comply with Hewlett Packards PCL level 3 printer language.

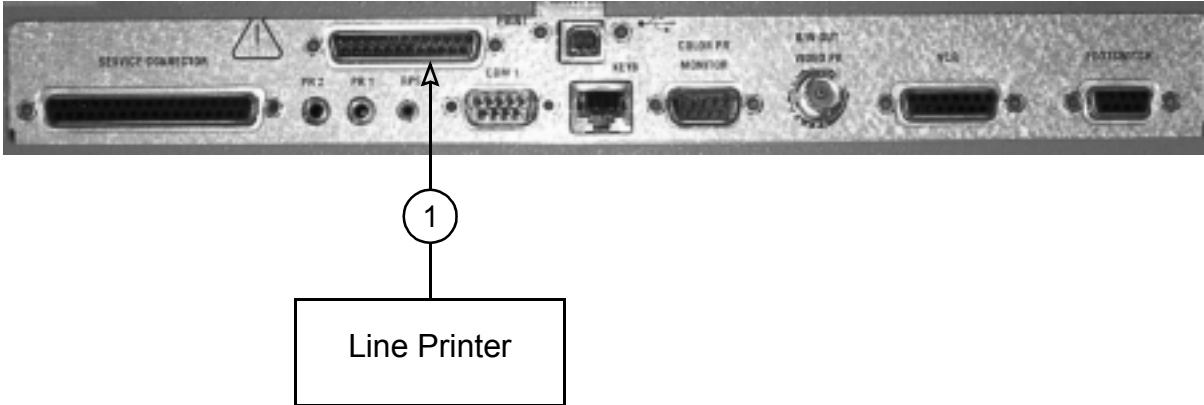

Figure 2-20: Connection of Line Printer

The recommended printers are HEWLETT PACKARD Deskjet 930C, Deskjet 950C, Deskjet 990Cxi and 9xx series. For these printers, a parameter set can be saved by the system.

2.9.10.1 Printer settings

The user preferences for the printer are available from the second page of the Preference System Menu:

SETUP > Prefs > System.

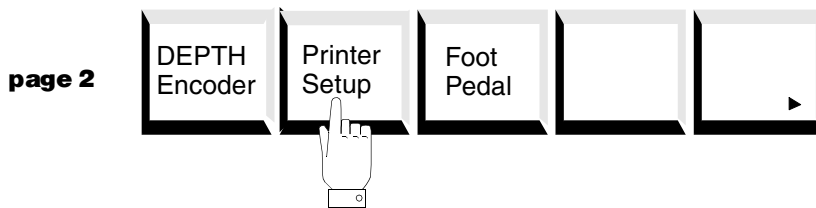

When “Printer Setup” key is pressed (F2 key), the following screen is displayed:

14/02/01 08:30:31

— GENERAL —

Images per page:	1 <input checked="" type="checkbox"/> 2	Background color:	<input checked="" type="checkbox"/> White
	3 <input type="checkbox"/> 4		<input type="checkbox"/> As is
	5 <input type="checkbox"/> 6	Paper size:	<input checked="" type="checkbox"/> A4
Font type:	Courier		<input type="checkbox"/> US Letter
	<input checked="" type="checkbox"/> Times	Paper type:	<input checked="" type="checkbox"/> Plain
	Univers		<input type="checkbox"/> Glossy
Print borders:	<input checked="" type="checkbox"/> Yes <input type="checkbox"/> No		<input type="checkbox"/> Transparency
Print head/foot:	<input checked="" type="checkbox"/> Yes <input type="checkbox"/> No	Background printing:	<input checked="" type="checkbox"/> Yes <input type="checkbox"/> No

General	Header & Footer	Gamma	Default	
---------	-----------------	-------	---------	--

The button “General” (F1 key) is automatically selected and general printer parameters are displayed. The selection of a parameter is easy: the cursor is placed on a field of interest, the corresponding text is display in inverse video. This field is selected using the up left trackball key: a tick mark is displayed in front of it. Note that only one parameter can be selected in a group (paper size, paper type,...). The different groups are explained below.

Once all the desired parameters are chosen, the user selection is validated by leaving the “Printer Setup” menu with ESC. The NoVRAM is then updated.

The “Default” key restores the default values and stores them in the NoVRAM. The default values are given in the following sections.

□ **General Parameters**

- Images per page

This parameter selects the number of images to be displayed on a page. The size and the position are optimized in order to maximize the image size.

Available values: 1, 2, 3, 4, 5 and 6 images per page

Default value: 2 images per page

The following page layouts are defined:

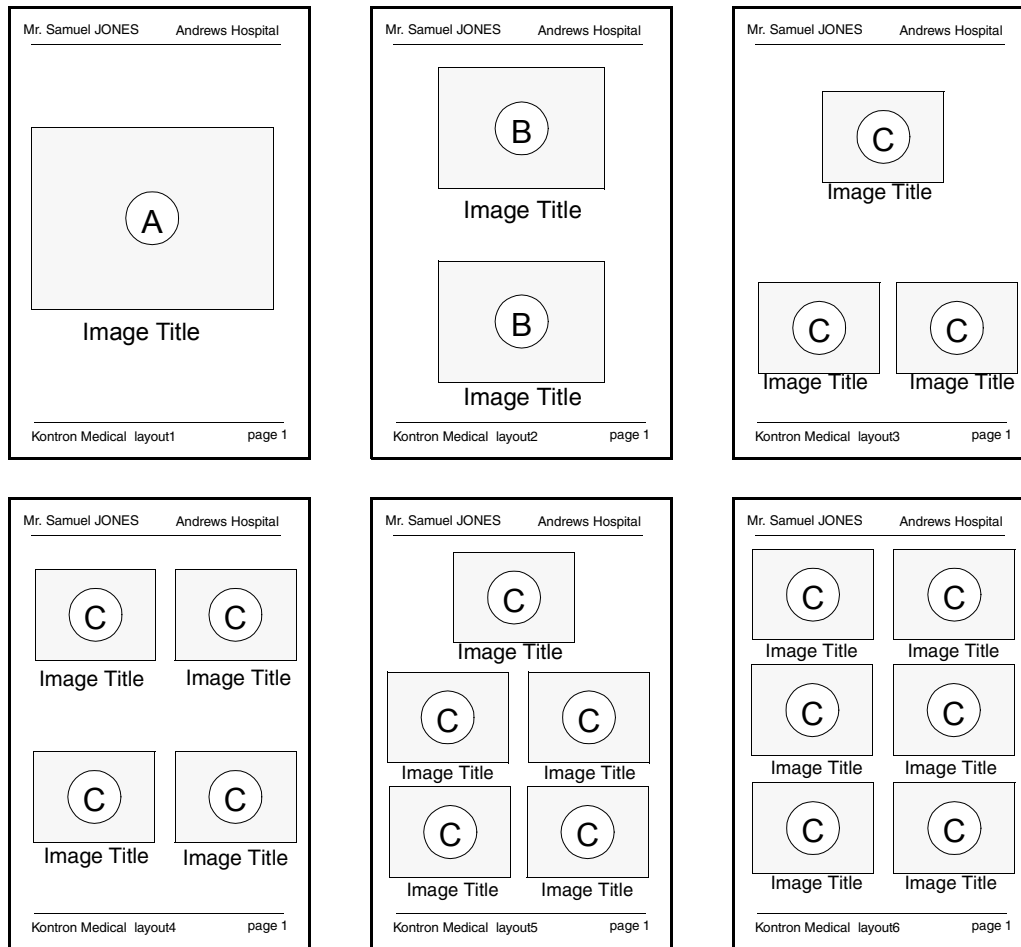

Figure 2-21: Predefined page layouts

These layouts are available with both A4 and US letter formats.

A: Image size 16.8 cm x 12.7 cm.

B: Image size 11.2 cm x 8.5 cm.

C: Image size 8.4 cm x 6.4 cm.

- Font Type

Available values: Courier, Times, Univers.

Default value: Times

- Print Borders

This parameter displays a black border around each image.

Available values: yes and no.

Default value: yes

- Print Head/Foot

This parameter displays a header and a footer on each page.

Available values: yes and no.

Default value: yes

- Paper color

This parameter selects the way the background has to be displayed. The background can be displayed in white or as is, i.e. as saved on the flash card.

Available values: "white" and "as is"

Default value: white

- Paper Size

Available values: A4 and US letter.

Default values: A4 for PAL video systems and US letter for NTSC video systems.

- Paper Type

Available values: plain, glossy and transparency

Default value: plain

- Background process

This parameter manages the print task. If the user selects *yes*, he can use the SIGMA normally but print process will take more time, else the SIGMA is no more available during the printing.

Available values: yes and no.

Default value: yes

□ **Header & Footer**

When "Header & Footer" is pressed (F2 key), the following screen is displayed:

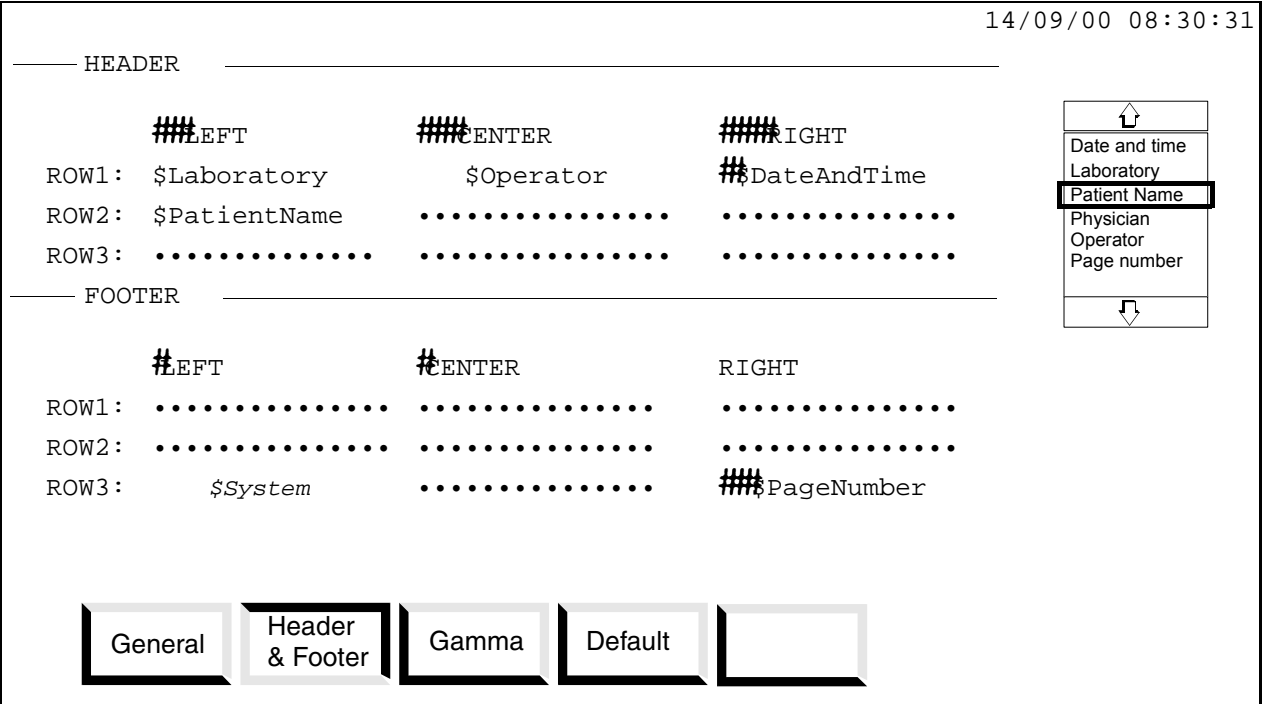

14/09/00 08:30:31

###LEFT	###CENTER	###RIGHT
ROW1: \$Laboratory	\$Operator	##\$DateAndTime
ROW2: \$PatientName
ROW3:

#LEFT	#CENTER	RIGHT
ROW1:
ROW2:
ROW3: \$System	###\$PageNumber

General
Header & Footer
Gamma
Default

Three lines are reserved for the header, three others are for the footer. On each line, three places are available: right aligned, centred or left aligned.

A popup menu is displayed on the right side of the screen. It contains the name of some predefined system variables: date and time, operator,...

The user may select one of these "system variables" to place it in any field.

Note that the KONTRON MEDICAL copyright and the system type are printed left aligned on the third line of the footer (Cf. § • Copyright and System values on page 2-30). This field cannot be neither moved nor deleted.

- Definition of the header and footer

The definition of the footer and header is equivalent:

Using the trackball, the user selects a location. The selected field is displayed in inverse video.

Now, if the user presses the backspace key the selected field is deleted,

Else, if he presses the “Enter” key or the up left trackball key the edition mode is turned on.

In edition mode, the user can select predefined variables from the popup menu.

The “Enter” key or the up left trackball key validates then the definition of the field.

Note that the ‘\$’ character is used as a leading character for predefined variables name.

These steps must be fulfilled for each field to print in the footer or in the header.

When all the relevant fields are defined, the user saves its work by leaving the “Printer Setup” menu. These fields are then stored in NoVRAM and retrieved each time the system is started.

If the user presses the “Default” key, the default values are restored. Default values are defined in the figure above.

- Copyright and System values

The *\$System* parameter describes:

the KONTRON MEDICAL mark

the system type: SIGMA 110, SIGMA 330, ...

and is defined in the following way:

the text is:

“SIGMA 330, KONTRON MEDICAL” for a SIGMA 330 system

“SIGMA 110, KONTRON MEDICAL” for a SIGMA 110 system

the text must be discreet, and so it will be displayed using a special font style (italic).

Note: The user cannot delete the system variable.

- Variables deletion

The user can delete a variable by pressing the <SPACE> key or the <BACKSPACE> key.

□ **Gamma**

When “Gamma” is pressed (F3 key), the following screen is displayed:

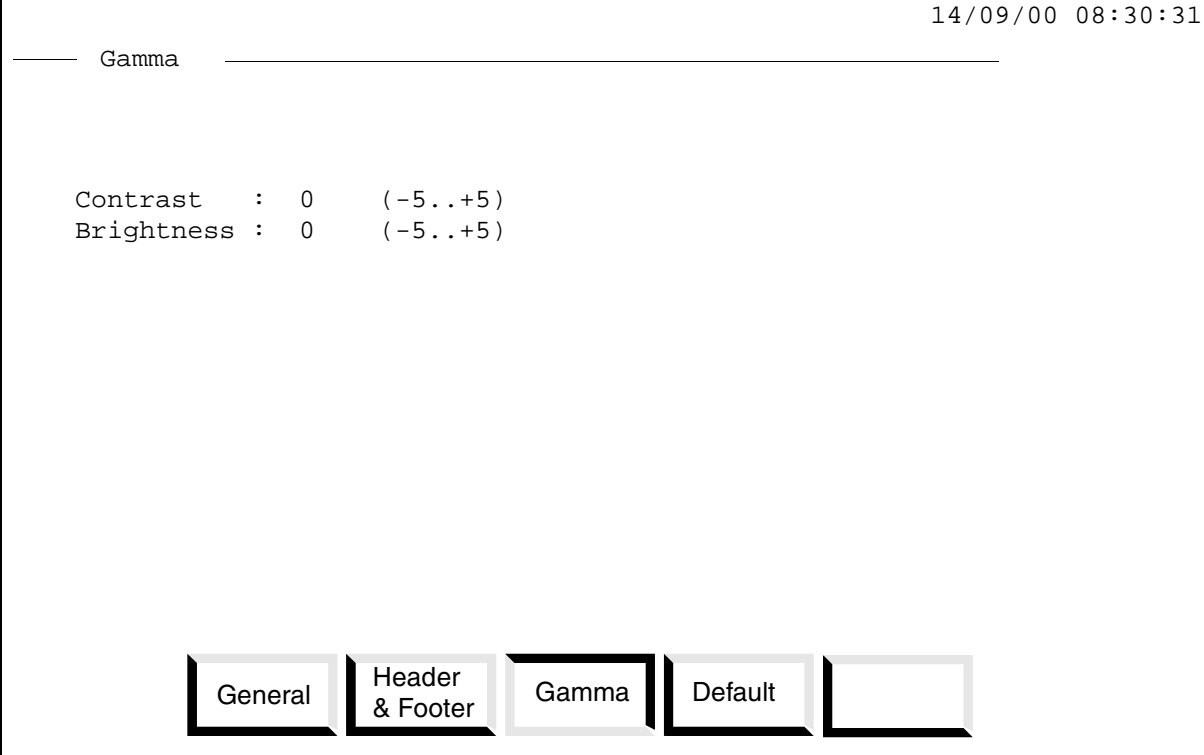

```
14/09/00 08:30:31
----- Gamma -----
Contrast  : 0   (-5..+5)
Brightness: 0   (-5..+5)

General  Header & Footer  Gamma  Default  
```

From here, the user can tune the printers gamma and correct the output image. The user can change both contrast and brightness. He saves its setup by leaving the “Printer Setup” menu.

2.9.11 Connection with medical grade isolators

When required, KONTRON MEDICAL can provide medical grade isolators on request. In case of doubt, for more details to connect additional peripherals contact your local distributor.

See also, Chapter III.2.1, “Electrical Safety”, on page -xix and Chapter 2.9.1, “Electrical safety with peripherals”, on page 2-15.

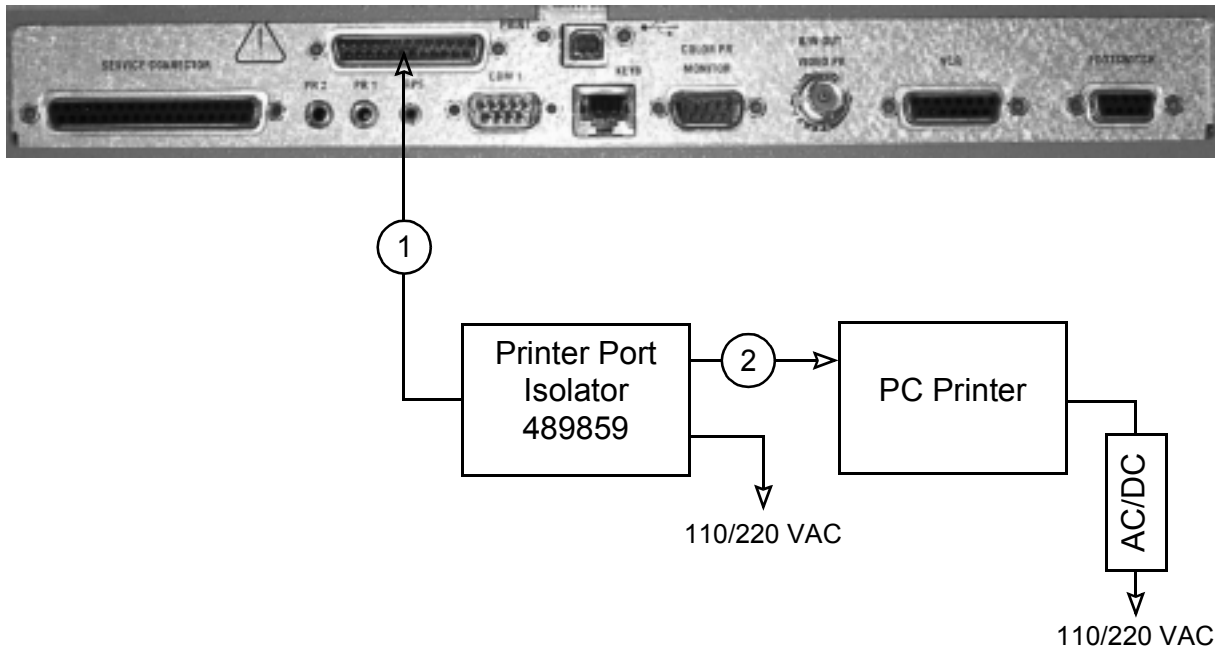

Figure 2-22: Connection with isolating accessories

1. Reference 490 199: Cable DSUB 25 M/F, L = 1.5 m
2. Reference 870 072: Cable PC/Printer, L = 1.8 m

2.9.12 Connection with S-Video Distributor

When required, KONTRON MEDICAL can provide medical grade isolators on request. In case of doubt, for more details to connect additional peripherals contact your local distributor.

See also, Chapter III.2.1, “Electrical Safety”, on page -xix and Chapter 2.9.1, “Electrical safety with peripherals”, on page 2-15.

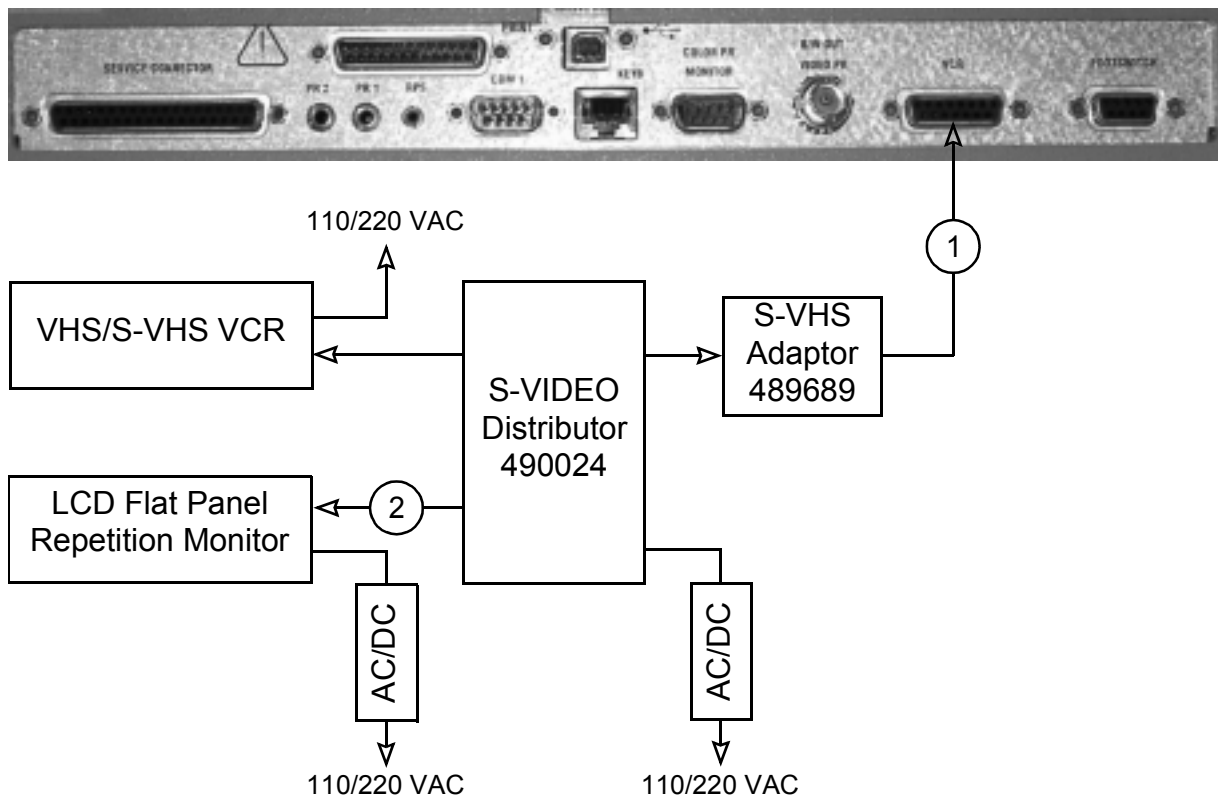

Figure 2-23: Connection with isolating accessories

1. Reference 481 076: signal cable for S-VHS VCR
2. Reference 441 562: S-VHS signal cable for EYE-Q 300M

This page is intentionally left blank

3. OPERATING INSTRUCTIONS

3.1 Operating Precautions

If the SIGMA 110/330 is being plugged in for the first time, refer to Chapter 2.7, “Power Source Connection”, on page 2-10.

Connect the mains inlet connector to a suitable supply source.

Make sure that the power line supply complies with the voltage selected on SIGMA 110/330.

Be certain that the power source receptacle is a 3 pin socket with the third pin grounded.

Note:

The unit can be connected to the patient's bed by using the equalization potential terminal (Chassis Ground); see figure 1-10, “SIGMA 330 Expert rear panel”, on page 1-23.

Check the connections of transducers, auxiliary and optional equipment, such as recorders (VCR), printers and other peripherals.

Make sure that connections are properly and securely made and that cables and connectors are in good condition:

- Cables free of unnecessary stress or friction for the length of the cable.
- Cables covering and insulation undamaged.
- Connectors secured at the cable end and matching securely at connection.

3.2 Switching the Instrument ON

3.2.1 Switching ON SIGMA 110 and SIGMA 330 Master

The power ON/OFF sequence consists of 3 states: Instrument OFF, STAND-BY, ON.

To switch the instrument ON:

1. Push the **ON/OFF** power switch on the rear panel of SIGMA 110 (see figure 1-12, "SIGMA 110 Light, Master and SIGMA 330 Master rear panel", on page 1-26). The green power indicator lamp, located in front of the control panel, will blink. This light shows that the system is in wait state.
2. When the power indicator lamp blinks, press the **ON/OFF** key on the keyboard or on the remote control.

A beep sounds when the program enters the start-up procedure. The green power indicator lamp, located in front of the control panel, illuminates. The initialization sequence starts, see Chapter 3.2.4, "Initialization of SIGMA", on page 3-5.

3.2.2 Switching ON SIGMA 330 Expert

The power ON/OFF sequence consists of 3 states: Instrument OFF, STAND-BY, ON.

To switch the instrument ON:

1. Push both **ON/OFF** power switches on the rear panel at the bottom and behind the monitor of SIGMA 330 (see figure 1-10, "SIGMA 330 Expert rear panel", on page 1-23). The green power indicator lamp, located in front of the control panel, will blink. This light shows that the system is in wait state.
2. When the power indicator lamp blinks, press the **ON/OFF** key on the keyboard or on the remote control.

A beep sounds when the program enters the start-up procedure. The green power indicator lamp, located in front of the control panel, illuminates. The initialization sequence starts, see Chapter 3.2.4, "Initialization of SIGMA", on page 3-5.

3.2.3 Switching SIGMA 330 Excellence ON

The power ON/OFF sequence consists of 3 states: Instrument OFF, STAND-BY, ON.

To switch the instrument ON:

1. Push both **ON/OFF** power switches on the rear panel at the bottom and behind the monitor of SIGMA 330 (see figure 1-10, "SIGMA 330 Expert rear panel", on page 1-23). The green power indicator lamp, located in front of the control panel, will blink. This light shows that the system is in wait state.
2. When the power indicator lamp blinks, press the **ON/OFF** key on the keyboard or on the remote control.

A beep sounds when the program enters the start-up procedure. The green power indicator lamp, located in front of the control panel, illuminates. The initialization sequence starts, see Chapter 3.2.4, "Initialization of SIGMA", on page 3-5.

The compact internal PC is automatically started, the Flat Panel Monitor is lighted (if not, press the Power ON button) and "Starting up for Windows® 2000 Pro" appears on the PC screen.



For operating SIGMA 330 Excellence or PC applications such as 3D Imaging, see Chapter 3.7.6, “3D imaging”, on page 3-46 and Chapter 3.20, “Integrated PC (SIGMA 330 Excellence)”, on page 3-110.

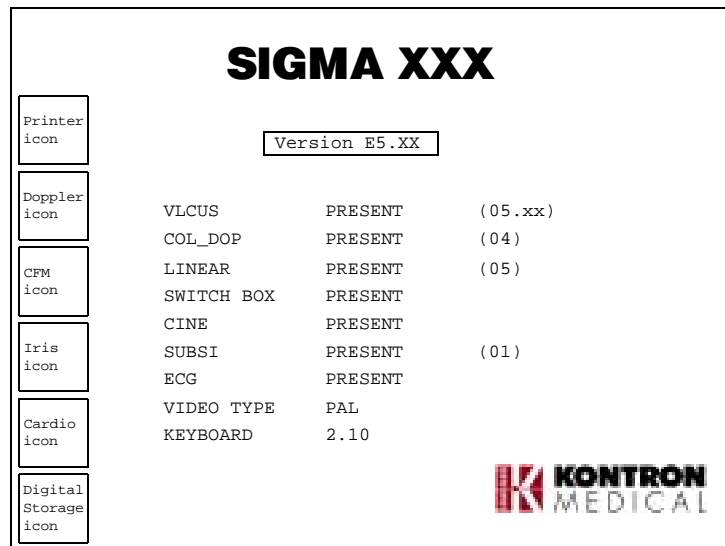

3.2.4 Initialization of SIGMA

After a short delay, the system displays the "welcome" screen:

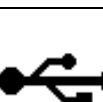

- ❑ SIGMA xxx displays the SIGMA type (110 Light, 110 or 330)
- ❑ The software version and the installed hardware are displayed
- ❑ SIGMA configuration icons:

Icon	Description
	Displayed when Easy-Print™ option is available
	Doppler icon means that the Spectral Doppler features are available
	CFM icon means that the Colour Doppler features (Colour Flow Mapping) are available
	Displayed when USB-Link™ option is available

Icon	Description
	Iris icon means that the Iris features and colour monitor are available
	Cardio icon means that the Cardio features are available
	KIPRISM icon means the Digital Storage features are available

A "progress bar" indicates the machine is initialising.

Then the 2D image area and PROBE Menu are displayed (except when a user setup shows another mode).

Note :

After turning the system off, always wait five to ten seconds before turning the power on again.

3.3 Switching the Instrument OFF

3.3.1 Switching OFF SIGMA 110 and SIGMA 330

To switch the instrument OFF, press the power **ON/OFF** key on the keyboard. The Power OFF Menu is displayed:



- Press **POWER OFF** (F1) to confirm the current switching OFF sequence
- Press **CANCEL** to abort the current switching OFF sequence

This switching OFF sequence is designed to avoid switching OFF by mistake.

After the POWER OFF confirmation, the power indicator blinks and the instrument is in stand-by mode.

With the remote control, the machine can be powered off immediately if the user presses the **POWER OFF** button.

Press the power switch on the rear to completely switch the machine OFF.

Note:

When the instrument is not used for 10 minutes, the image automatically goes into frozen state. Then, most function keys become inactive. A beep warns the user. Press **FREEZE** key to return to previous mode.

3.3.2 Switching OFF SIGMA 330 Excellence

To switch the instrument OFF, press the power **ON/OFF** key on the keyboard. The Power OFF Menu is displayed:

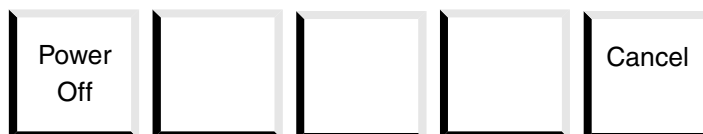

- Press **POWER OFF** (F1) to confirm the current switching OFF sequence
- Press **CANCEL** to abort the current switching OFF sequence

(This switching OFF sequence is designed to avoid switching OFF by mistake.)

- Select Shut Down on the PC dialog
- The system is automatically powered off

After the POWER OFF confirmation, the power indicator blinks and the instrument is in stand-by mode.

Press the power switch on the rear to completely switch the machine OFF.

3.4 Menus

Menus are used to access functions or parameters. There is a specific menu for each mode, for setups and for processing features settings (see mode selection chapters in Chapter 3.7, “Major Modes”, on page 3-25).

The menus are displayed in gray.

The inside text is displayed in black if the menu button is selected and in white if not.

3.4.1 Notes

- The following syntax is used in this document to describe the formats:
[XX]/YY describes a dual format with pad XX being active.

3.4.2 Menu Key Conventions

As a general convention, the menu keys are always displayed in the same place independent of the modes.

A menu key can be enabled, disabled or not available. If a menu key is disabled it is drawn ghosted. If it is not available it is not drawn at all.

The following rules are used to distinguish between disabled and not available menu keys:

- If the functionality represented by the key is enabled in one mode but doesn't work in another mode, the key is disabled in the other mode.
- If the functionality is never enabled in any mode, it is not available and so not displayed.
- Exceptions which will improve the user interface are introduced.

3.4.3 Menu Types

Two different types of menus can be displayed according to whether the current application is single or double.

A Single Menu consists of one Menu Item row that can contain two character lines (see figure 1-16, “Single Menu Display”, on page 1-36).

A Double Menu consists of two Menu Item rows that contain one character line each (see figure 1-17, “Double Menu Display”, on page 1-37).

3.4.4 Menu Display

Note that the menu corresponding to the active mode is automatically displayed when the user enters the mode.

The user can also press the **PREVIOUS** (<) or **NEXT** (>) keys to access in a circular fashion the previous or next menu page (if more than one menu page exists in the current menu).

Note: the > symbol in the lower right corner of menu field M5, M10, M20,... is only displayed if more than one menu page exists.

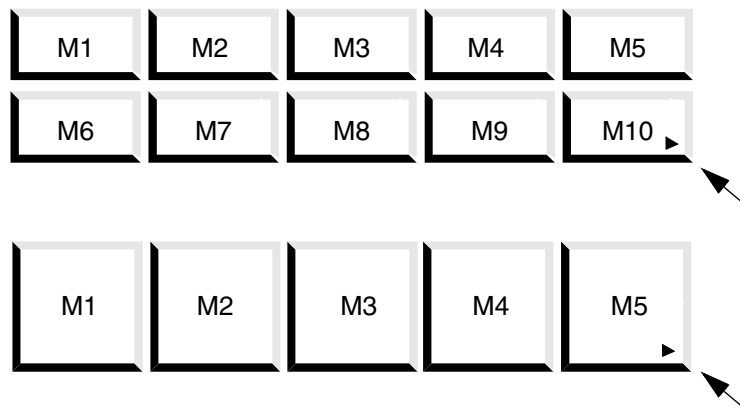

To hide (and disable) a menu, press the **MENU** key.

The menu is hidden during the print phase and displayed again when printing is finished.

3.4.5 Menu Items

There are two types of menu items: selectable and incremental.

- ❑ Choosing a selectable menu item causes the action to be carried out immediately when the associated key is pressed.
- ❑ Choosing an incremental menu item dedicates the incremental potentiometer to the current action when the associated key is pressed. The \updownarrow Symbol is used to identify an incremental menu item (e.g. for Angle or Vector adjustment).

The related Function keys (F1 to F10) are used to select Menu Items (see figure 1-16, “Single Menu Display”, on page 1-36 and figure 1-17, “Double Menu Display”, on page 1-37).

3.4.5.1 Selectable Menu Items

- ❑ Selectable Menu Items

The user only needs to press the associated function key to activate the action.

- ❑ Selectable menu items with toggle action

Toggle menu items have a different behaviour: the menu item string changes dynamically and describes the next action to be performed when the button is pressed and not the state of the system.

For instance: Up/Down image inversion in 2D mode is controlled by the 2D Inv. menu item as follows:

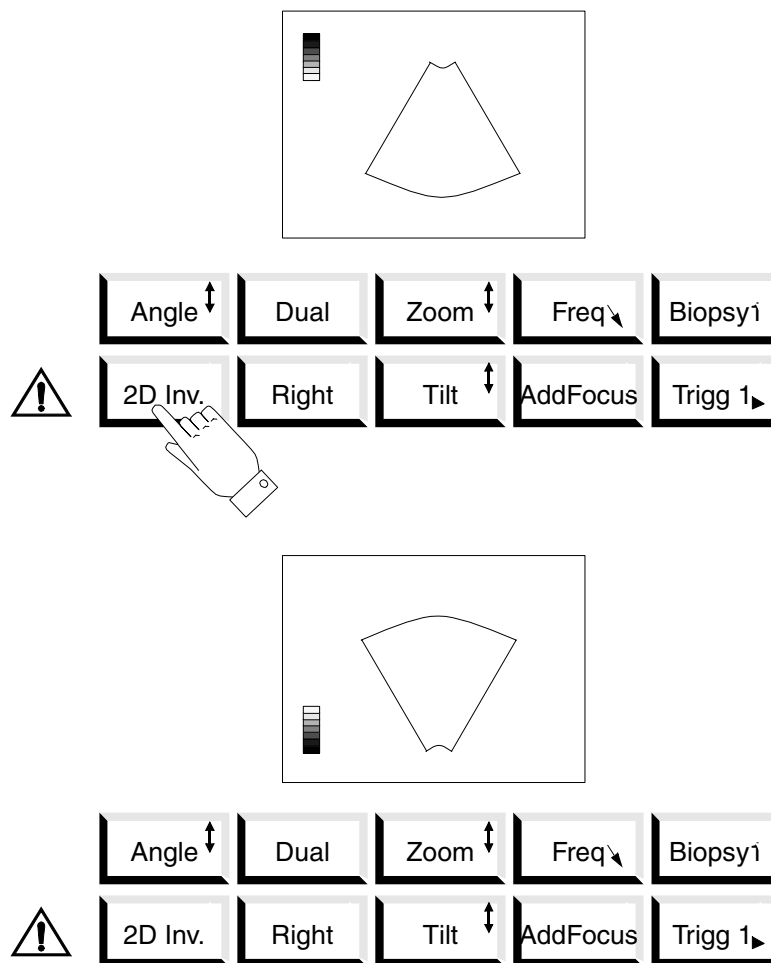

Convention: Throughout this document toggle menu items contain the symbol "/", such as Left/Right ..., but note that only Up or Down will be displayed at a given time.

3.4.5.2 Incremental Menu Items

Incremental menu items are associated with the adjustment of a parameter. The user presses the associated function key to select the item and eventually adjusts (increments or decrements) the parameter using the incremental potentiometer.

Turn the button clockwise to increase the parameter value and counter clockwise to decrease it; when the minimum or maximum value is reached a beep warns the user.

For example to change the angle of 2D sector:

1. Select the **Angle** (F1) function key
2. Turn MP left or right to decrease/increase the scanning angle

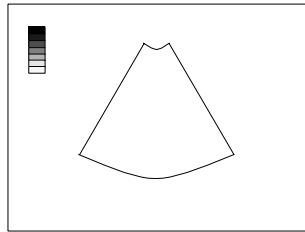

1.

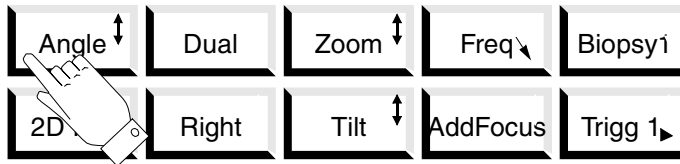

2.

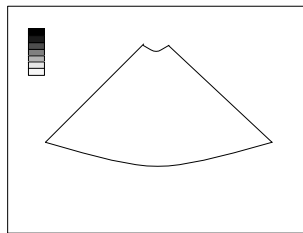
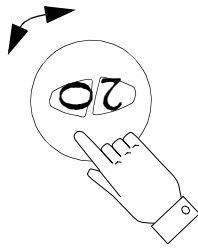

3.5 Probes

3.5.1 Probe Selection

Press the **PROBE** key to display the Probe Menu. This menu shows the names of the probes that are connected to the system. Up to 5 probes can be simultaneously connected to SIGMA 330 Expert including Doppler function and SIGMA 330 Excellence, 4 probes for SIGMA 110 Master and SIGMA 330 Master models including Doppler option; and 3 probes for the SIGMA 110 Light including Doppler option:

- Two Linear Probes (or Convex Linear Probes), one Doppler Probe (Pencil Probe) and two AS probes for **SIGMA 330 Expert** and **SIGMA 330 Excellence**.
- One Linear Probe (or Convex Linear Probe), one Doppler Probe (Pencil Probe) and two AS probes for **SIGMA 110 Master** and **SIGMA 330 Master**.
- Two Annular Sector probes and one Doppler probe (pencil probe) for **SIGMA 110 Light**.

The following drawing shows the probe menu with 4 probes connected. The probe which is selected by default when switching the instrument on can be determined by the user via the Setup menu. Pressing F2 softkey selects the probe connected to connector "P-3" (e.g. 5.0 GP).

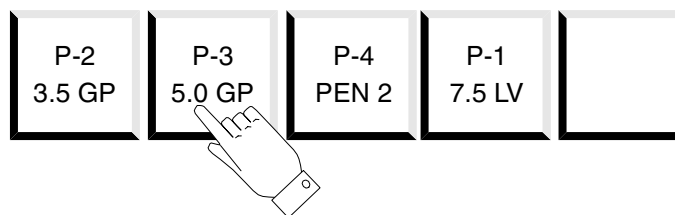

When selecting Probe, the system looks for a setup for this probe. First priority search is user setup; second priority search is factory setup.

3.5.2 Menu Display

The key corresponding to the current probe used is displayed pressed.

If a probe is not recognized by the system (bad ID), "Invalid Probe" is displayed instead of the probe name and the key is disabled.

If a probe is recognized by the system but can't be used (e.g. Pencil probe with no doppler board), the probe name is displayed but the key is disabled.

3.5.2.1 *Probe Main Menu, with One Linear Probe*

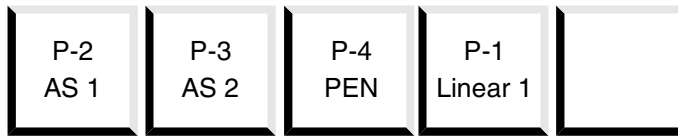

3.5.2.2 *Probe Main Menu, with Two Linear Probes*

(SIGMA with Switch Box)

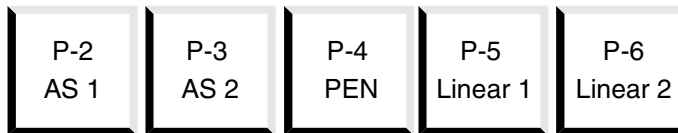

The recommended probes according to Medical Applications, are listed in the table i on page xvi. The main features of the probes are shown in the table ii on page xviii.

3.6 Setup

This function allows the user to select factory or user setup parameters. Factory Setups are pre-set by the Manufacturer and cannot be modified by user. User Setups are created by users and can be modified, renamed and deleted. Each Setup is assigned to one probe and stores all the user accessible parameters for all the scanning modes (2D, TM, ..., 2D + TM, ...), depending on the dedicated application.

3.6.1 Setup Menu



Press **SETUP** on the user interface to display the setup menu.

3.6.2 Loading a Setup

Press **Load SETUP** (F1) function key to select a dedicated setup of the current probe. The System displays only the setups dedicated to the current probe, including the Factory Setups.

The Factory setups are always displayed after the user setups.

User setups are displayed in upper case and factory setups in lower case.

At most 20 user setups can be defined for all probes. If more than 5 setups exist for the current probe, a second page is added to the menu; each setup page is accessed by using **PREVIOUS** (<) or **NEXT** (>) key.

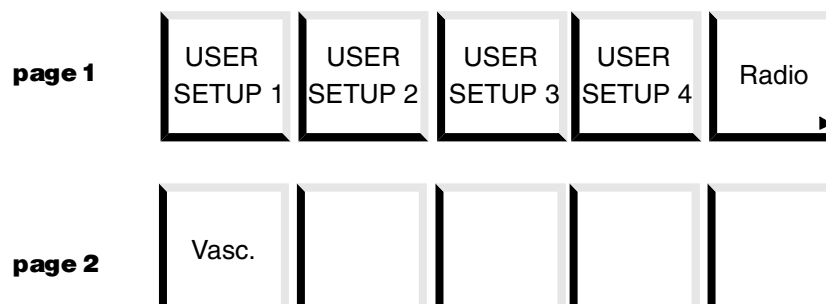

3.6.3 Saving a Setup

The user can save more than one setup for each probe and up to 20 setups for all probes.

To save a Setup:

1. Press **SETUP** key to enter SETUP menu.

2. Press **Save Setup** (F2)
3. Press **New Setup** (F1)

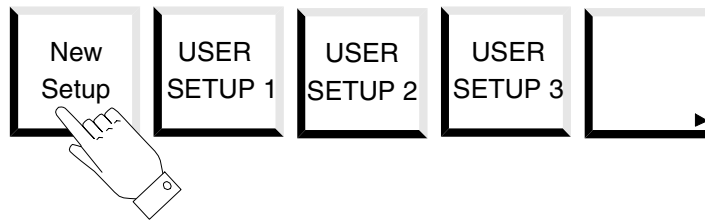

4. Enter the new setup name using the alphanumeric keyboard
5. Validate with **RETURN** key

The sequence can be aborted at any time using the **ESC** key.

A new user setup has been created and stored in the system. It appears in the setup menu.

Press **ESC** key to return to previous menu. For renaming a setup, the user must select the setup and save it again on itself. For saving, a new name is always requested.

3.6.4 Deleting a Setup

To delete a User Setup:

1. Press **Delete Setup** (F3). The Delete Setup Menu displays all user setups stored in the system (for every probe and every application).
2. Select the setup to be erased with the corresponding function key. The confirmation menu is displayed.
3. Answer Y (Yes) to confirm or C to cancel the erasing sequence.

3.6.5 Preferences

Press **Prefs** (F4) function key of SETUP menu to display the preferences menu.

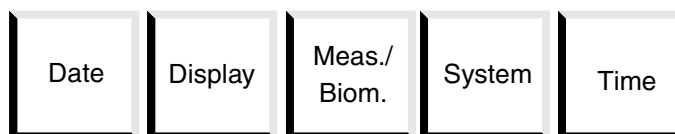

3.6.5.1 Date

The system displays the date. According to the version PAL or NTSC, the date is automatically displayed in a specific order:

- DD/MM/YYYY for the PAL version (DD: day, MM: month, YYYY: year)
- MM/DD/YYYY for the NTSC version (DD: day, MM: month, YYYY: year)

Using the Date menu the user can modify the current date of the system. The Date menu includes Day, Month, Year, Validate and Abort keys:



To modify the day (e.g.):

1. Press **Date** (F1)
2. Press **Day** (F1)
3. Rotate the softpot to get the right day
4. Then press **Validate** (F4)

Proceed similarly for changing month and year.

3.6.5.2 Display

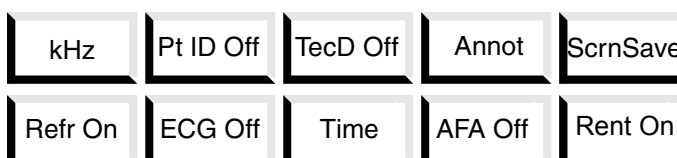

- ❑ Doppler scale: m/s or kHz
Doppler information can be shown in m/s or kHz. Use **m/s / Hz** (F1) function key to select the desired scale.
- ❑ Patient Identification: On/Off
Patient Identification can be displayed on the screen. Use **Pat ID** (F2) function key to display or not the Patient Identification.
- ❑ Technical Data: On/Off
Technical Data can be displayed on the screen. Use **TecD** (F3) function key to display or not the Technical Data.
- ❑ Annotation:

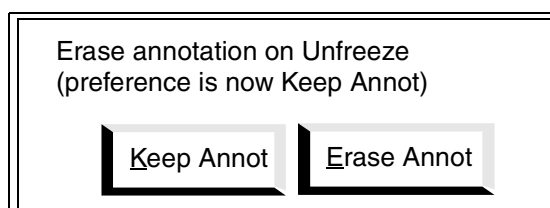

The annotations displayed on the screen are kept or erased when the display is unfrozen. Choose between keep or remove annotations with the **Annot** key (F4). Press on the character corresponding to the first letter of the strings in the buttons.

□ Screen Saver:

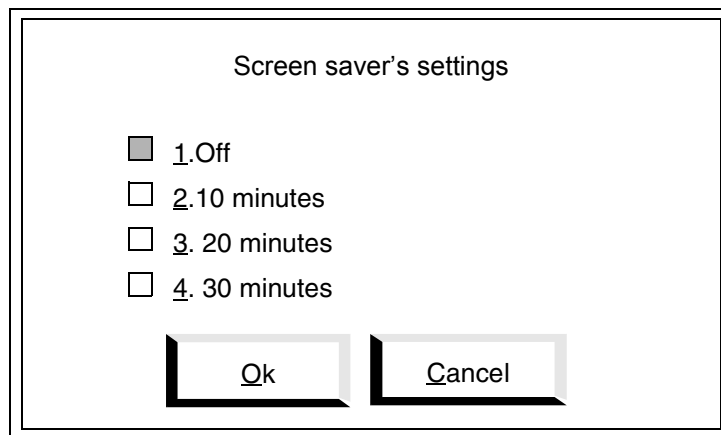

With this dialogue box, the user can select the time until a screen saver will be started if the machine is not used. By touching any key or the trackball the screen saver will be stopped. The default value is off.

□ Refresh: On/Off

Refresh function in Doppler and TM modes can be enabled or disabled. Use **Refr** (F6) function key to enable or not this function. When it is on, 2D image is refreshed at the end of each SP or TM sweep.

□ Time

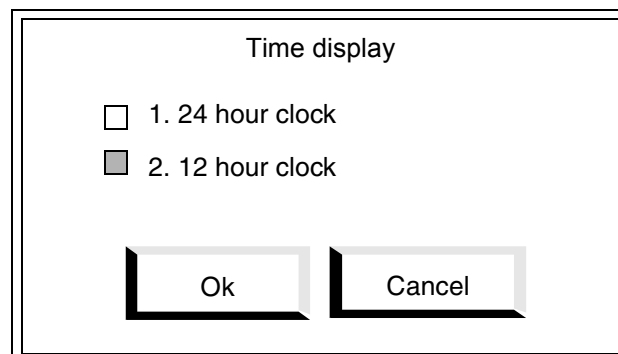

The user can select Time display on 24 hours or on 12 hours.

Default setting is 24 hours for PAL (ex: 14:50:36)

Default setting is 12 hours for NTSC (ex: 2:50:36 PM)

□ AFA

Enables or disables the display of Automatic Frequency Adjustment marker in 2D.

□ ECG: On/Off

ECG function can be enabled or disabled. When it is on, ECG trace is displayed on the screen. Press **ECG** function key (F7) to toggle.

□ Rent: On/Off (Time Renting option)

Enable or disable display of time renting informations.

3.6.5.3 Measurement and Biometry Preferences

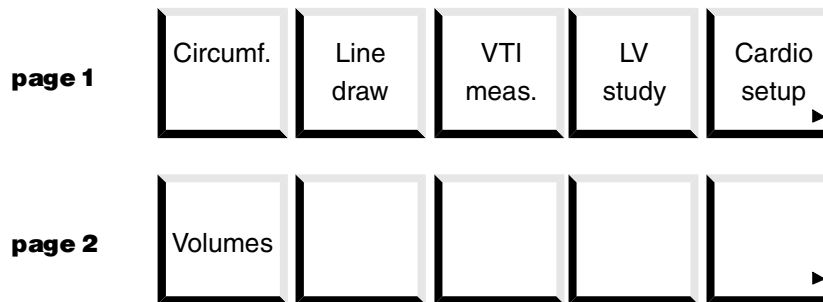

□ Circumference

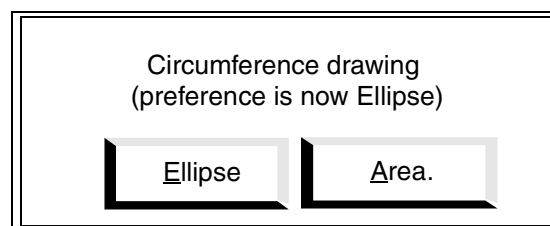

In Obstetrics, the circumference measurements (Abdominal circumference and Head circumference) are made from either Ellipse or Area drawing. User can select either Ellipse or Area in SETUP/Preferences menu using **Circumf.** (F1)

- Preference for Ellipse: circumference is computed from ellipse circumference.
- Preference for Area: circumference is computed from area contour.

Press the character corresponding to the first letter of the strings in the buttons to select your option.

□ Line draw: dashed line/no line

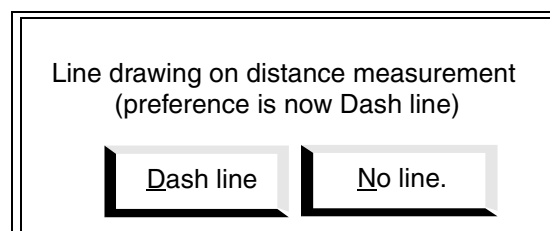

Distance measurement can be initialized with two different types of drawing. User can select either Dash line or No line in SETUP/Preferences menu, using **Line draw** (F2).

- Preference for Dash line: a dashed line is drawn between the two end points of the distance to be measured.
- Preference for No line: there is no line between the two points.

Press on the character corresponding to the first letter of the strings in the buttons to select your option.

- LV Study: default mode for LV Study

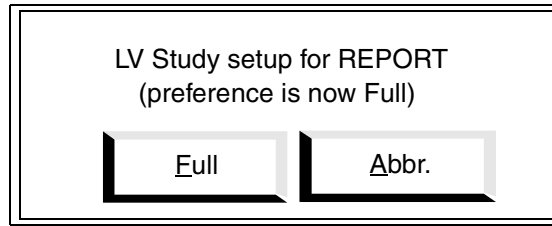

LV Study can be initialized in two different modes. User can select either Full LV-study or Abbreviated LV-study with **LV Study** (F4) function key.

Press on the character corresponding to the first letter of the strings in the buttons to select your option.

- VTI: default mode for VTI measurement

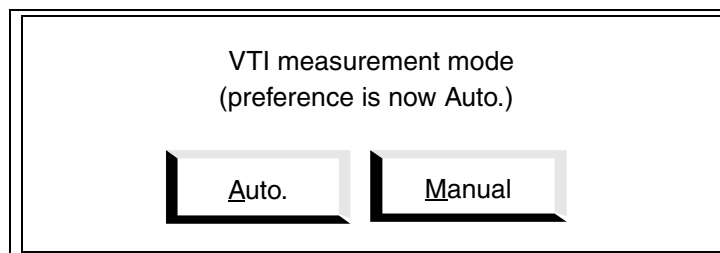

VTI measurement can be initialized either in Automatic or in Manual mode with **VTI Meas.** function key (F3).

Press on the character corresponding to the first letter of the strings in the buttons to select your option.

- Cardio setup:

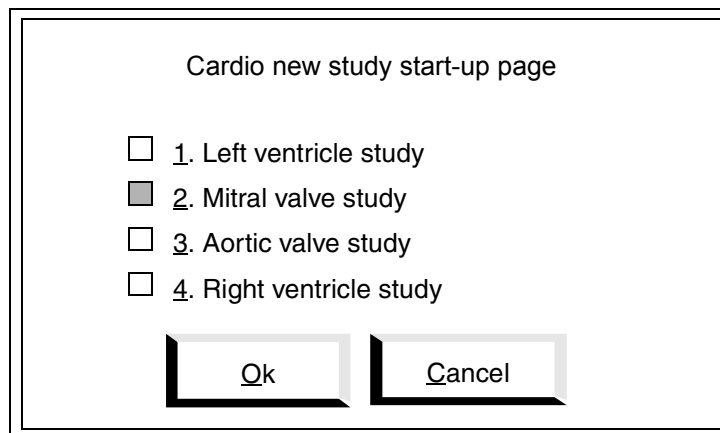

With this dialogue box, the user can select the page which is to be displayed each time a new Cardio Study is displayed.

- Left Ventricle Study: Press alphanumeric key "1"
- Mitral Valve Study: Press alphanumeric key "2"
- Aortic Valve Study: Press alphanumeric key "3"
- Right Ventricle Study: Press alphanumeric key "4"

Press the character corresponding to the first letter of the strings in the buttons to validate or cancel your action.

□ Volumes

The standard Radiology Study REPORT page is displayed. The user can define the calculation type for the volume measurement.

3.6.5.4 System

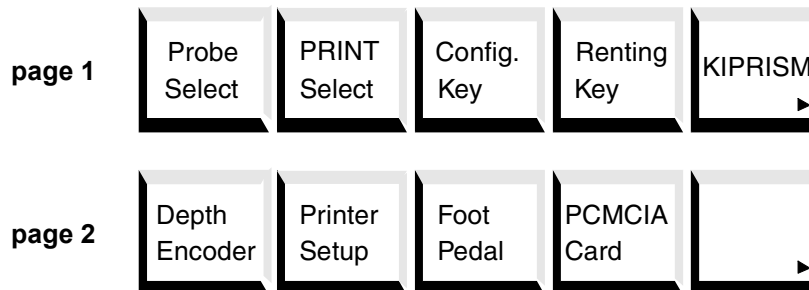

□ **Probe Select:** Probe selection at switching on.

The Dialogue box allows the user to determine which probe is selected when the system starts.

At switching on, the system searches probes that are connected and starts with the one that is selected in the dialogue box for probe preference.

- configuration with one Linear/Convex Probe:

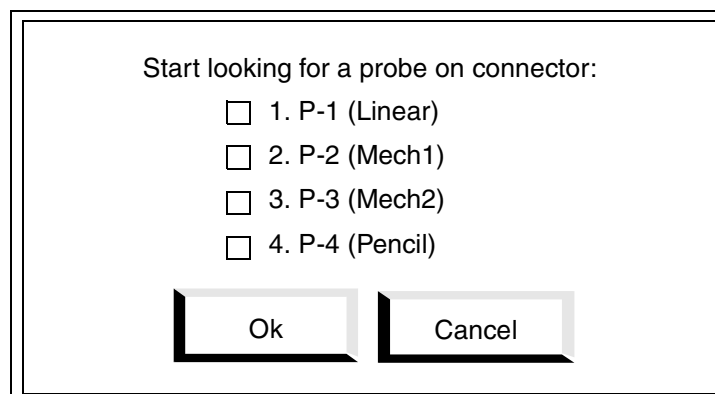

- configuration with two Linear/Convex Probes:

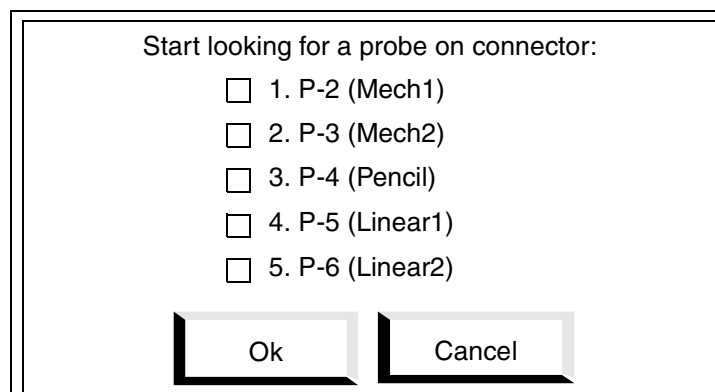

Press on the character corresponding to the first letter of the strings in the buttons to validate or cancel your option.

□ **PRINT Select**

With the **PRINT select** key the user can assign the PRINT2 key of the keyboard and the PRINT key on the remote control to following functions:

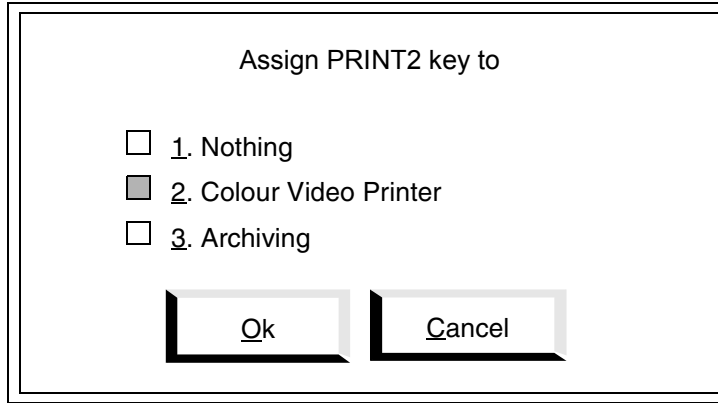

- Nothing: PRINT2 key has no function (press alphanumeric key "1")
- Colour Video Printer: If PRINT2 is assigned to the Colour Video Printer, the key generates a remote signal for a colour video printer which can be attached only to SIGMA 330 systems (press alphanumeric key "2").
- Archiving: PRINT2 key acts as save key if KIPRISM is installed on the system and a formatted Flashcard is entered in the slot. (press alphanumeric key "3")
The actual image is stored in memory by pressing the PRINT2 key. If the KIPRISM option is enabled, the default action is set to the image storage.
In this case:
 - The user can save images when the machine is in LIVE mode.
 - a beep is generated if there is no space left on the memory card or if the flash card system is not correctly formatted.

Press the character corresponding to the first letter of the strings in the buttons to validate or cancel your action.

Then the next dialogue box appears:

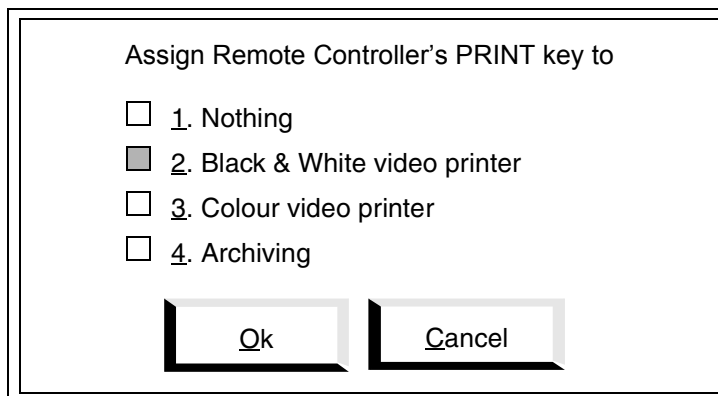

The functions are the same as for the PRINT2 configuration.

□ **Config. Key**

The **Config Key** is used to enter the keywords that enable the EasyPrint options. These keywords are provided by the factory.

□ **Renting Key**

Press this key for entering new time renting credit to the system. These keywords are provided by the factory.

□ **KIPRISM**

With the **KIPRISM** key the user can select a black background or a white background when storing images on memory card.

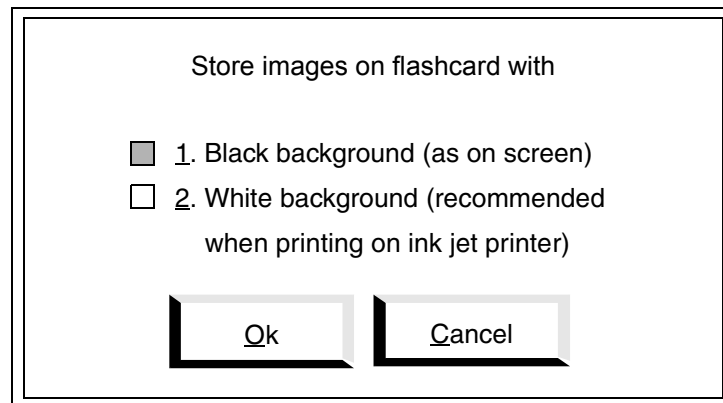

- Press alphanumeric key "1" to select a black background.
- Press alphanumeric key "2" to select a white background. This option is recommended when printing on ink jet printer.

□ **Depth encoder**

Depth encoder preference allows the user to select the sense of the DEPTH encoder:

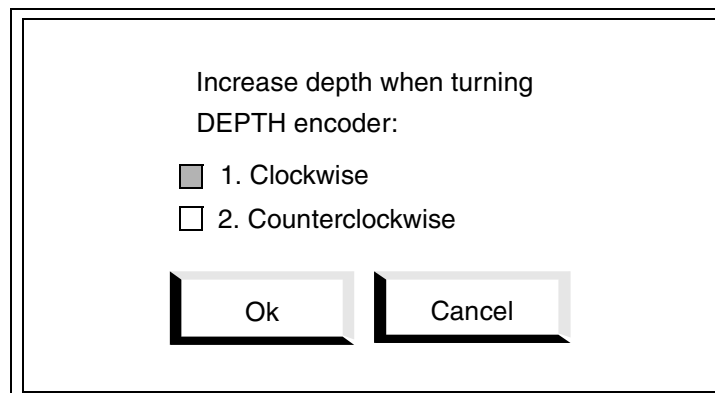

- Press alphanumeric key "1" to select "Clockwise" : turning the Depth encoder clockwise increases depth.
- Press alphanumeric key "2" to select "Counterclockwise".

□ **Printer Setup**

Press this key to display the screen for setting the printer parameters, see Chapter 2.9.10.1, "Printer settings", on page 2-26.

□ **Foot Pedal**

Foot Pedal allows the user to select the action associated to the left pedal of the footswitch. The right pedal is always assigned to FREEZE/UNFREEZE.

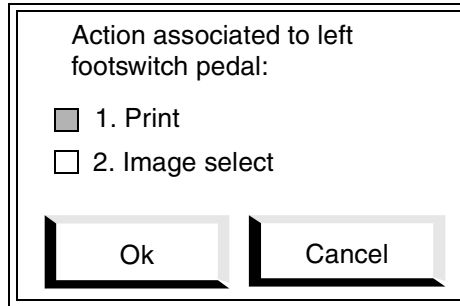

□ **PCMCIA Card**

PCMCIA allows the user to select the option "Read only or Full access" for the PCMCIA memory card..

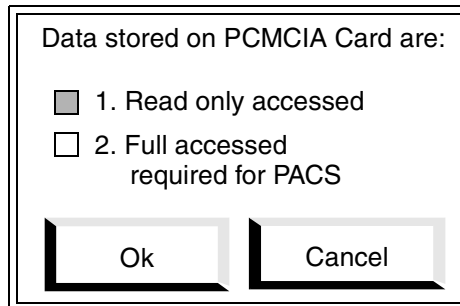

3.6.5.5 Time

The system displays the current time. Using the Time menu the user can modify the current time of the system. The Time menu includes Hour, Minute, Second, Validate and Abort keys.

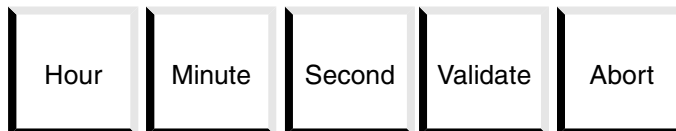

To modify the hour (e.g.):

1. Press **Time** (F5)
2. Press **Hour** (F1)
3. Rotate the softpot to get the right hour
4. Then press **Validate** (F4)

Proceed similarly for changing minute and second.

3.6.6 PCMCIA CARD

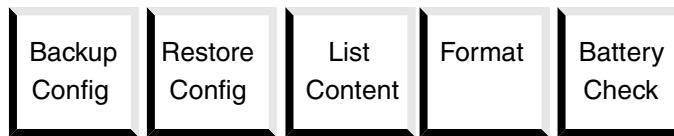

The system offers the possibility of saving and restoring user configurations using a PCMCIA memory card. This is very useful in case of multi-application and multi-user; each physician using the system can get a personal memory card to store his configuration.

- ❑ Backup Configuration

The function key **Backup Config** (F1) backs up the user configuration (laboratory, operator and physician names, Ob/Gyn setup and user reference tables, user probe setup and preferences) on the memory card. This operation must be done periodically and before any software update.
- ❑ Restore Configuration

The function key **Restore Config** (F2) restores the user configuration saved on the memory card and replaces the current settings with the restored ones.
- ❑ List Content

The function key **List Content** (F3) lists a summary of the memory card content: the laboratory, operator and physician names and the probe setup names.
- ❑ Format

The function key **Format** (F4) formats the memory card for digital archiving of ultrasound images.
- ❑ Battery Check

The function key **Battery Check** (F5) checks the battery charge level of the memory card. The following messages are returned:

 - BATTERY STATE: Full 100%, normal operating conditions
 - LOW BATTERY: exchange the battery as soon as possible.
 - EMPTY BATTERY: replace the battery immediately.

3.6.7 System Info

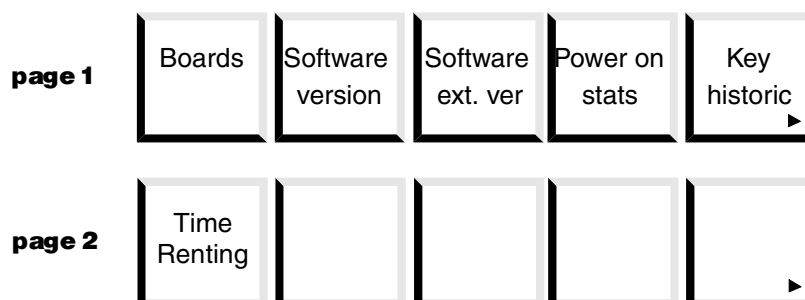

The System Information Menu allows the user to display:

- installed boards and their version
- software version

- extended software versions
- power on statistics
- key historic
- time renting information

3.7 Major Modes

SIGMA 110 can include four major imaging modes: 2D, TM, PW, CW (PW and CW are optional). SIGMA 330 can include five or six major imaging modes: 2D, TM, PW, CW, CFM and additionally 3D on SIGMA 330 Excellence (CFM and 3D are optional).

3.7.1 2D Mode









Press 2D key to select 2D mode (see figure 1-4, "Keyboard", on page 1-13 to locate the key).

Note

This mode is automatically set when the instrument is switched ON, if no personal setup has been previously defined and if the probe which is automatically selected by the system is able to do 2D.

3.7.1.1 2D Mode Selection

The legend used to identify the image state in the following pictures is shown below:

-  no ultrasound image
-  shading filling for live image
-  shading filling for frozen image
-  shading filling for refreshed image
-  this symbol shows the LEFT/RIGHT scanning direction
-  this symbol shows the selected image (live image or latest frozen image)
-  this symbol shows that image is frozen
-  trackball

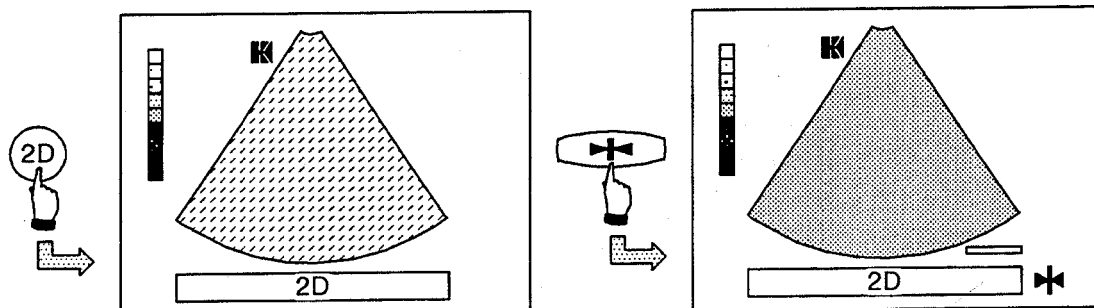

Figure 3-1: 2D Mode Selection

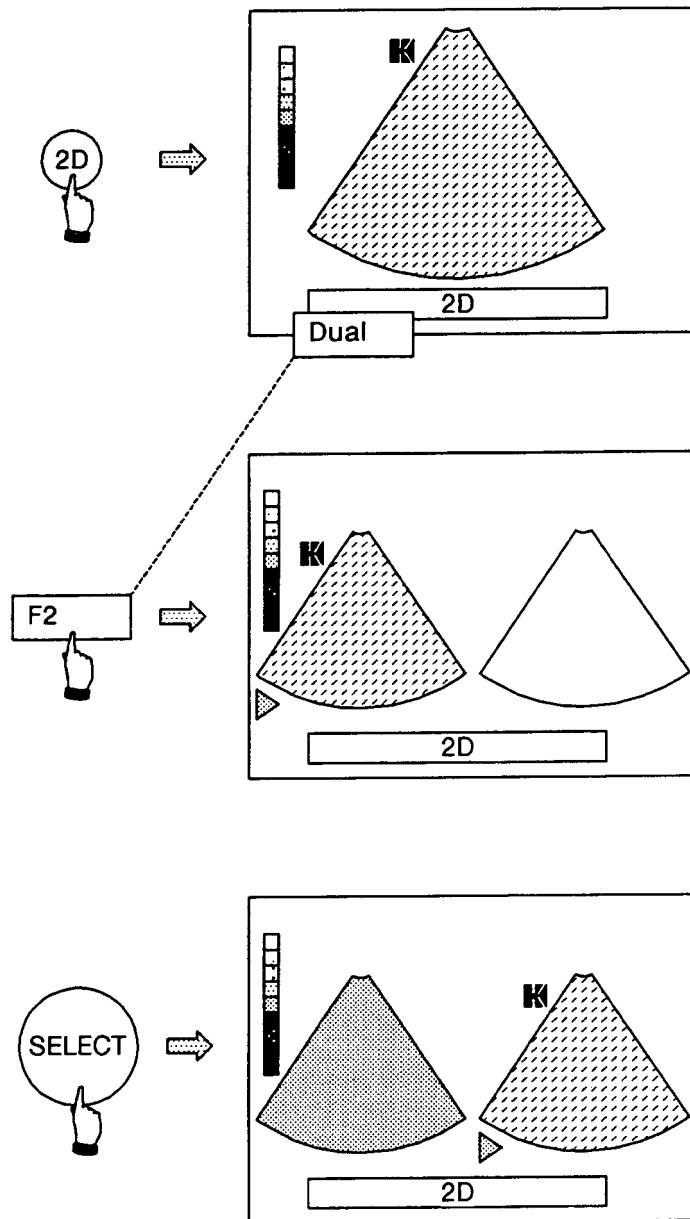

Figure 3-2: Double 2D Selection

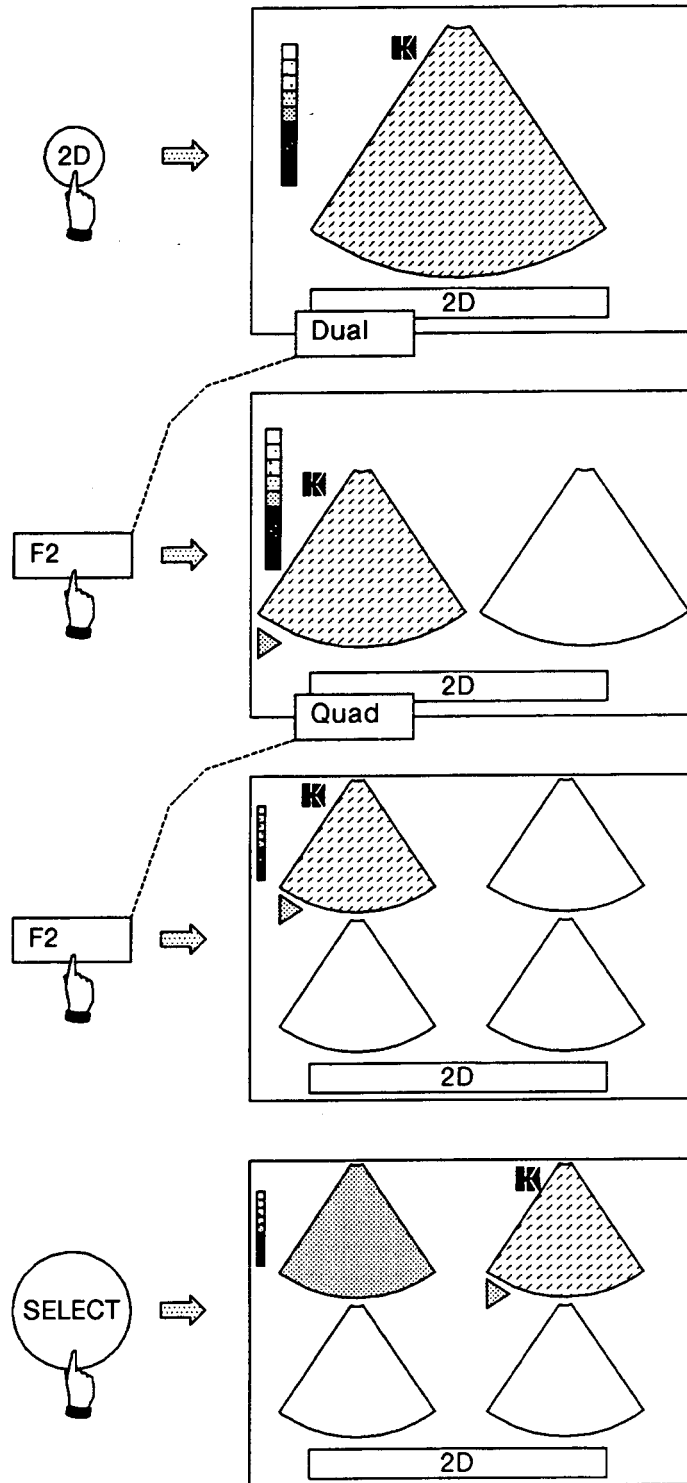
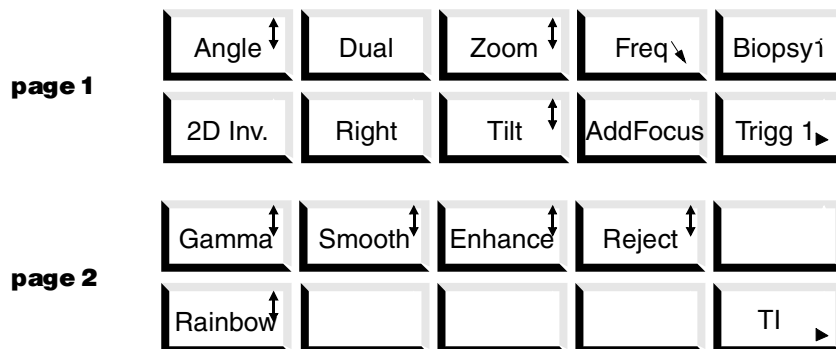

Figure 3-3: Quad 2D Selection

3.7.1.2 2D Live Menu

This menu is displayed in active 2D mode:



- **Angle**
This function allows the user to modify the angle of the image sector for **Annular Sector** and **Convex probes**. Use the MP potentiometer to select the desired angle. For available angles see table -ii, "Probe Features," on page -xviii.
- **Single/Dual/Quad**
This function displays single, double and quad multi-format. Select Dual to display double 2D images, then select Quad to display quad 2D images and select Single to return to single 2D image. In dual mode, press 2D to return to single 2D.
- **Zoom: Panoramic Zoom for Annular Sector probes**
Press Zoom to magnify an area of the ultrasound image. The trackball is used to select the area to be enlarged by moving a window on the image; the magnified zone is displayed beside the entire image. The softpot allows the image to be magnified by: 1.14 to 2.73. The magnifying factor depends on image depth; it is displayed in the technical data area on the right side of the screen. Press Single or turn the softpot counter clockwise to exit.
- **Zoom: Scrolling Zoom for Linear/Convex probes**
Press Zoom to magnify an area of ultrasound image. The trackball is used to move the enlarged area on the initial image, in the image depth direction; only the magnified zone is displayed. A Zoom Range Indicator is displayed on the left of the 2D Zoom Menu to locate the current enlarged area. For instance, the drawing below shows a full scale of 24 cm corresponding to the explanation depth of entire image and the displayed area (x 1.85), approximately from 5.5 to 18.5 cm.

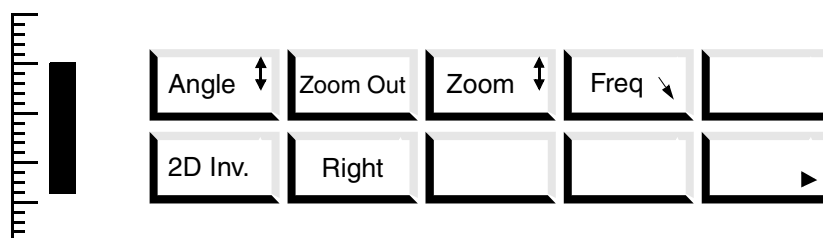

The magnifying factor depends on the image depth and the operating probe; according to depth, 1 to 3 magnifying factors are available. The softpot is used to select the desired magnifying factor: 1.15 to 3. The magnifying factor is displayed in the technical data area on the right side of the screen. Press Zoom Out to exit.

- **Freq ↑ / Freq ↓**

This function allows the user to choose Freq + (higher frequency) for a standard patient or Freq- (lower frequency) for a less echogenic patient. Pressing Freq ↓ decreases transmitting frequency and displays Freq- in the technical data area. Pressing Freq ↑ increases transmitting frequency and displays Freq+ in the technical data area on the right side of the screen.
- **Biopsy 1/2/OFF**
 - Biopsy 1 displays the biopsy guide lines on the screen in single 2D format. According to the operating probe, none, one or two guide lines are available. A biopsy kit including two needle guide inclinations can be fitted on the 6.5 MR multiplane transrectal probe; for this probe:
 - Biopsy 2 displays the second biopsy guide lines corresponding to the second inclination of needle guide.
 - Biopsy OFF is used to clear the screen of the lines.
- **2D Inv.**

This function reverses the up/down orientation of the 2D-image displayed on the screen.
- **Left/Right**

This function changes the left/right orientation of the 2D-image. The KONTRON MEDICAL Logo, at the top right/left of the 2D-image sector, indicates the image orientation.
- **Tilt**

This function is used to tilt 2D angle. It is useful with the transvaginal probe (6.5 EV only) for ovarian exploration. MP softpot shifts the image sector. A graphic symbol shows the shooting angle direction.
- **AddFocus**

For Linear/Convex probes it is possible to set up to four focus areas. Select "AddFocus" to add a focal point. Use the trackball to move it. When 4 focus zones are selected, pressing the "AddFocus" key sets the image back to 1 focus zone.
- **Trigger**

This function enables ECG trigger(s) when ECG Option is installed. See Chapter 3.16, "ECG (Option)", on page 3-95.
- **Gamma**

Eight compression curves (1 to 8) are selectable by using MP softpot. The first six ones vary gradually from dark and soft image (Number 1) to light and contrasted image (Number 6); the numbers 7 and 8 are inverted. Default Gamma setting is probe dependent.
- **Smooth**

Four different (0 to 3) settings of image filtering are selectable to improve image smoothness and reduce noise level. Smooth 0: without "Smooth" filtering.
- **Enhance**

This function offers the possibility to improve the image sharpening, enhancement of vessel wall and organ contour. Enhancement increases from number -3 to +3.
- **Reject**

This function controls the dynamic range of the ultrasound echoes and allows a better differentiation of tissues.

- Reject 0: maximum dynamic range, soft image.
- Reject 3: maximum rejection, more contrasted image.

❑ **Rainbow** (SIGMA 330 only)

This function controls the colourisation of the ultrasound image. The MP softpot allows the selection of 8 sets of colour (Rainb 0 to Rainb 7). The one selected is shown in the Technical Data Window. Rainb 0 corresponds to black and white image display. Rainb 1 to 7 correspond to colorised image.

❑ **T/MI**

This feature displays/hides the Thermal or Mechanical Indexes.

3.7.1.3 2D Frozen Menu

This menu is displayed by pressing the **FREEZE** button:



❑ **Store** (if KIPRISM is available)

To store the actual frozen image in memory, this button has to be pressed.

❑ **Archive** (if KIPRISM is available)

Enters the KIPRISM archive, if a minimum of one image is stored on the formatted Flash Card.

❑ **Cine**

Displays the menu dedicated to cine replay management.

For details of Store/Archive function see Chapter 3.11, “Digital Archiving: KIPRISM”, on page 3-51.

3.7.1.4 2D Gain

- ❑ Overall gain is controlled by rotating the uppermost knob on the right side of the keyboard. 32 positions are available.
- ❑ TGC is controlled by sliding the five rectilinear potentiometers on the top-right of the keyboard. These five compensation gain controls are independently acting on the corresponding exploration areas. Normal setting is all five TGC potentiometers centered.

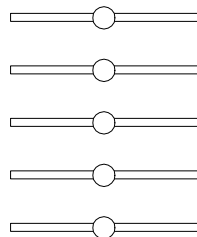

3.7.2 **TM (Time Motion)**

Press **TM** key to select TM mode (see figure 1-4, "Keyboard", on page 1-13 to locate the key).

The TM marker is positioned over the 2D image. The echoes corresponding to the selected beam are displayed on a scrolling trace.

1. The first time that you press **TM** key, you enter double image 2D+TM display. The TM line marker is superimposed on 2D live Image. The 2D/TM Menu is displayed on the screen. Use the trackball to move the line over the 2D image, so as to place it on the area which has to be studied.
2. Set the TM line to the desired position. When releasing the trackball the 2D image is automatically frozen and the Time Motion becomes active. If the TM line is repositioned using the trackball the 2D image will get unfrozen again. The 2D image can be refreshed at the end of each TM sweep. The "Refresh" option can be enabled or disabled in the "Preferences" Menu (**SET UP > Prefs > Display > Refr ON/OFF**).
3. If the user want to get the 2D image active without changing again to TM, press the **SELECT** key. To restart the automatic changing between 2D and TM press the SELECT key again.
4. Press a second time the **TM** key to display a TM single format.

3.7.2.1 TM Mode Selection

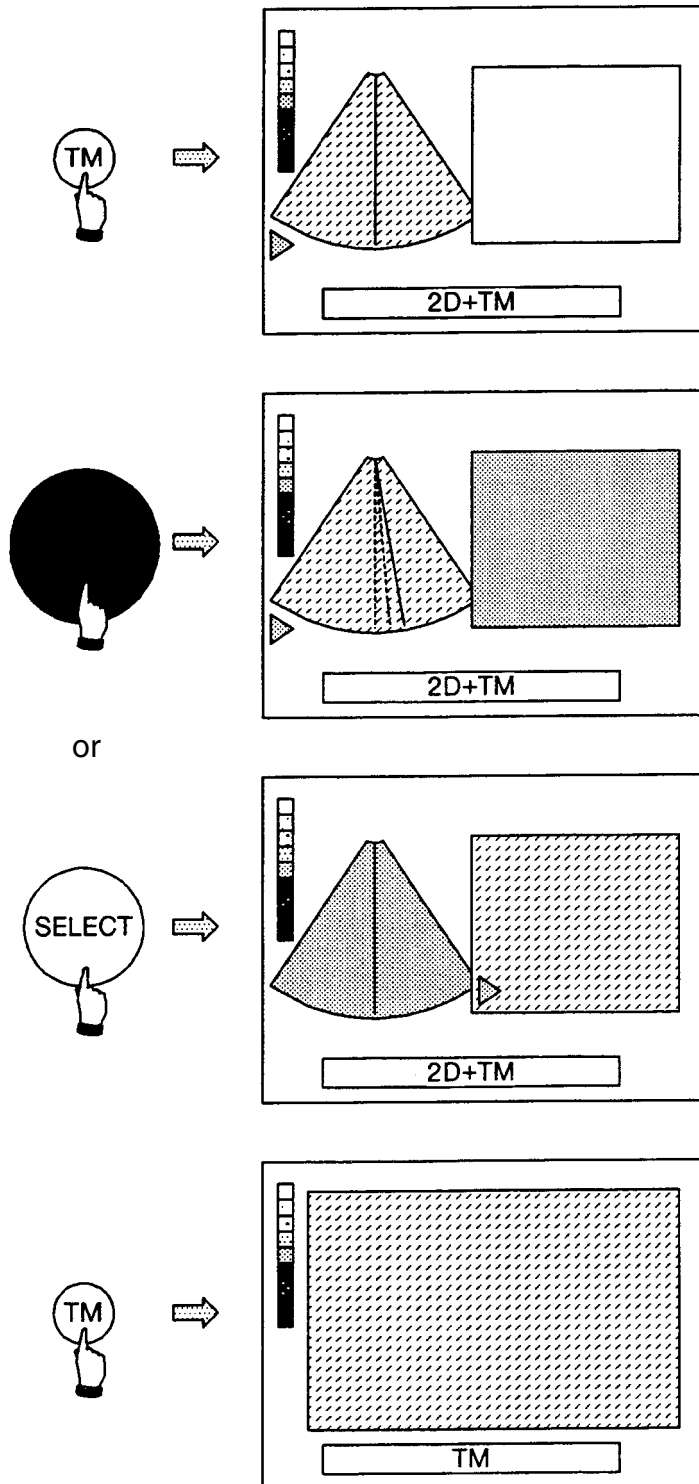
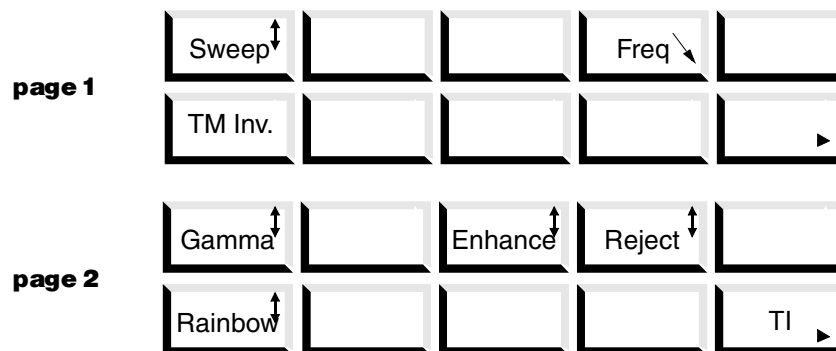

Figure 3-4: TM Mode Selection

3.7.2.2 TM Live Menu

This menu is displayed when TM mode is selected.



- **Sweep**
This function allows the user to select different time bases, approximately from 1 to 4 seconds in 2D + TM and 2 to 8 sec. in full screen TM. Turning the softpot clockwise increases scrolling speed and consequently decreases time base.
- **Freq ↑ / Freq ↓**
This function allows the user to choose Freq ↑ for a standard patient or Freq ↓ for a less echogenic patient.
- **TM Inv.**
This function reverses the up/down orientation of the 2D-image displayed on the screen.
- **Gamma**
8 compression GAMMA curves are selectable by using the MP potentiometer.
- **Enhance**
increasing contour enhancement to improve the image sharpening.
7 positions are available between -3 and 3.
- **Reject**
This function controls the dynamic range of the echoes that are displayed on the screen.
- **Rainbow (SIGMA 330 only)**
This function controls the colorisation of ultrasound image. The MP softpot allows the selection of 8 sets of colour (Rainbow 0 to Rainbow 7). The one selected is shown in the Technical Data Window.
Rainbow 0 corresponds to black and white image display.
Rainbow 1 to 7 corresponds to colorised image.
- **TI/MI**
Display/Hide Thermal or Mechanical Indexes.

3.7.2.3 TM frozen Menu

See 2D frozen menu in Chapter 3.7.1.3, "2D Frozen Menu", on page 3-30.

3.7.2.4 TM Gain

Overall gain is controlled by rotating the uppermost knob on the right side of the keyboard. 32 positions are available.

Slope is controlled by using 5 rectilinear potentiometers on the top-right of the keyboard.

3.7.3 PW Doppler

SIGMA 110 and SIGMA 330 can perform Pulse Wave Doppler (PW) if Doppler option is installed. Press **PW** key to select PW mode

1. The first time that you press the **PW** key, you enter PW mode, 2D+PW is displayed. The marker and the gate are displayed on the 2D image. The trackball allows the user to move the marker on the image and to slide the gate on the marker, to reach the required area.
If CFM option is installed (SIGMA 330), in CFM/PW mode the PW gate never exits the CFM window (region of interest). So, moving the PW gate moves also the CFM window.
2. Set the PW line to the desired position. When releasing the trackball the 2D image is automatically frozen and the PW mode becomes active. If the PW line is repositioned using the trackball the 2D image will get unfrozen again. The 2D image is refreshed at the end of each PW sweep. The "Refresh" option can be enabled or disabled in the "Preferences" Menu (**SET UP > Prefs > Display > Refr ON/OFF**).
3. If the user want to get the 2D image active without changing again to PW, press the **SELECT** key. To restart the automatically changing between 2D and PW press the SELECT key again.
4. Press a second time the **PW** key to display a 2D icon/PW format.

3.7.3.1 PW Mode Selection

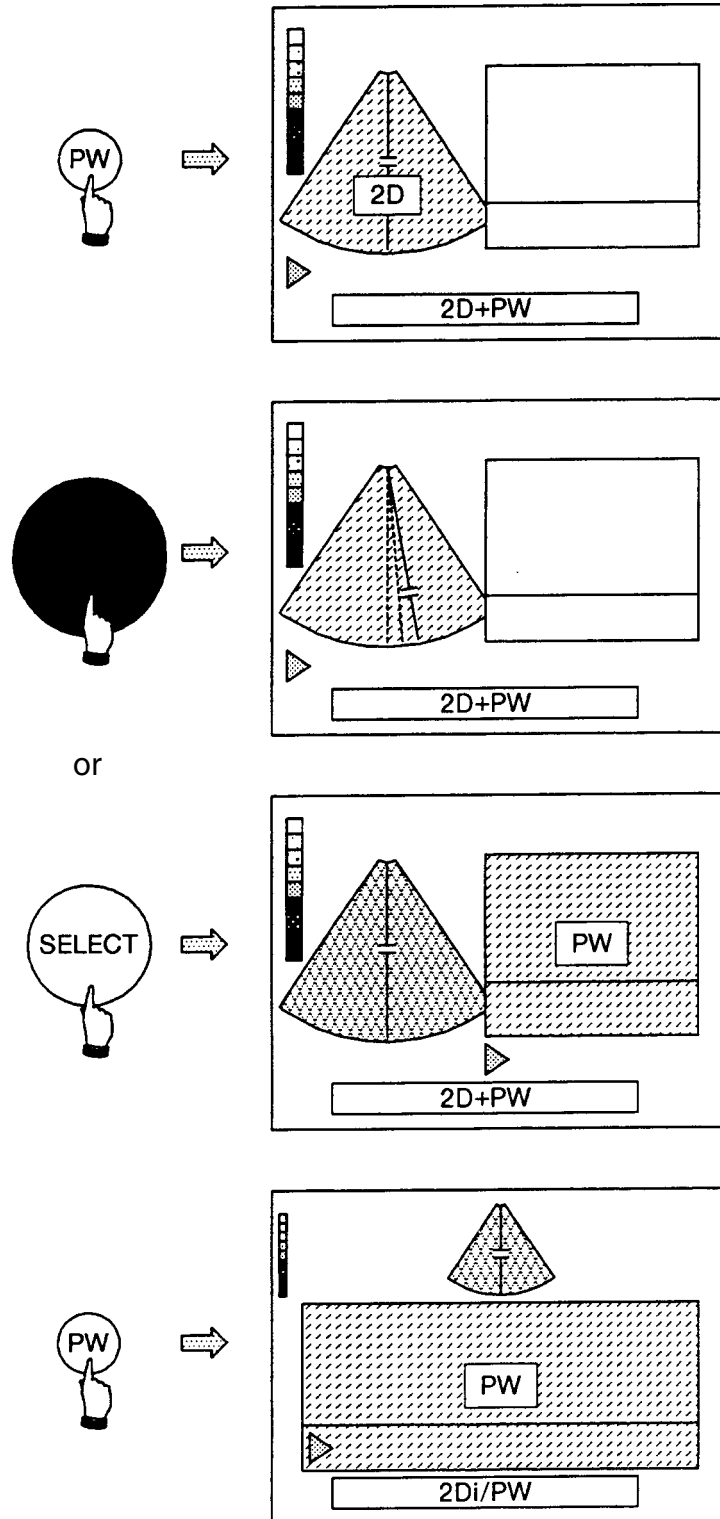
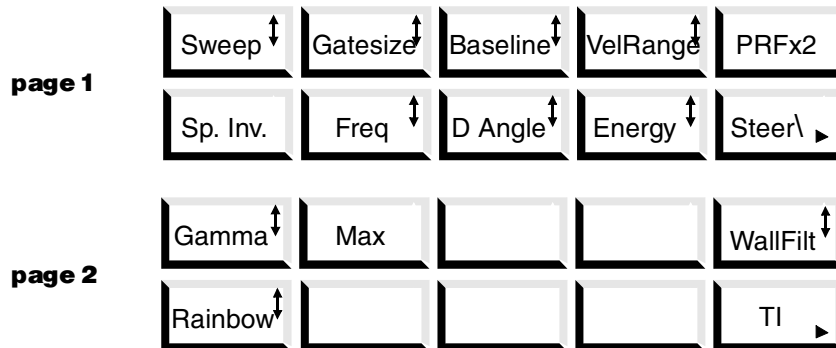

Figure 3-5: PW Mode Selection

3.7.3.2 PW Live Menu

If PW is active the following SP menu is displayed on the screen (2D+PW display).



- **Sweep**
This function allows the user to select different sweep speeds, approximately from 1 to 4 seconds in 2D + SP and 2 to 8 sec. in full screen SP. Turning MP potentiometer clockwise increases scrolling speed and consequently decreases time base.
- **Gatesize**
This function adjusts gate size. The user can select a sample volume size of: 1, 2, 4, 6, 8, 10, 12 and 15 mm.
- **Baseline**
The soft-pot shifts the spectrum baseline. 9 positions are selectable: -100, -75, -50, -25, 0, +25, +50, +75, +100%.
- **VelRange**
This function changes the Velocity Range. Velocity range depends on Doppler frequency. It can be displayed in kHz or m/s. When selecting m/s, it is displayed in cm/s for velocities lower than 1 m/s and in m/s for velocities greater than 1m/s.
- **PRF/PRFx2/PRFx3**
This function changes the Pulse Repetition Frequency. PRFx2 and PRFx3 are extended ranges where PRF is multiplied by 2 and 3 respectively.
- **WallFilt**
This function is used to select the wall filter cut-off frequency. The selected frequency value is displayed on the screen in the technical data area on the right side of the screen. The following wall filter frequencies are available: 50, 75, 100, 150, 200, 300, 400, 500, 750, 1000 Hz.
- **Sp. Inv.**
This function reverses the up/down orientation of the spectrum displayed on the screen.
- **Freq**
This function is used to select the different Doppler frequencies: 2, 3, 4, 8 MHz Doppler frequencies are available and can be selected by using MP potentiometer. An optimized Doppler frequency is automatically selected according to the operating probe. However, the operator can select another frequency (except for pencil probes).

Note :

The available Doppler frequencies are dependent of the selected probe. For instance, Pencil Probes are used at only one frequency.

- ❑ **D Angle**
 This function is used to adjust angle correction. Use the MP potentiometer to rotate the flow direction cursor on the line marker. The angle is adjustable from -70 to 70 degrees. The velocity scale is automatically changed according to the angle.
- ❑ **Energy**
 This parameter depends on operating probe and its dedicated applications. It is stored in the Factory Setup. When selecting Energy, the associated MP potentiometer allows the user to reduce the transmit energy: 0, -3, -6, -9, -12, -15, -18, -21 dB attenuation. 0 dB corresponds to maximum energy which is smaller or equal to the recommended level for the selected application (see Chapter 1.7.12, “Acoustic Power”, on page 1-51).
- ❑ **Steer**
 This function is available when Linear Probe is selected. It allows the user to choose the steering angle of the Doppler beam: no steering, left steering, right steering. The steering angle depends on the selected probe and the emitted frequency.
- ❑ **Gamma**
 When selecting Gamma, the associated MP potentiometer selects different compression curves which perform a compression of spectrum gray levels on the screen.
- ❑ **Max / Mean / Max+Mean**
 SIGMA 110 and SIGMA 330 can calculate mean and max velocities and display the corresponding curves on Doppler spectrum. This button functions in a circular manner:

 - **Off**: no trace display
 - **Max**: display of Vmax+ and Vmax- curves in orange on Doppler spectrum.
 - **Mean**: display of Vmean curve in blue on Doppler spectrum.
 - **Max + Mean**: display of Vmax+ and Vmax- curves in orange and Vmean curve in blue simultaneously on Doppler spectrum.

Note :

The automatic integral or PI/RI calculations are based on Vmax trace. They can be selected even though Vmax trace is not displayed. MVI is based on Vmean trace.

- ❑ **Rainbow** (SIGMA 330 only)
 This function controls the colorisation of spectrum image. The MP softpot allows the selection of 8 sets of colour (Rainbow 0 to Rainb 7). The selected one is shown in the technical data area on the right side of the screen.
 Rainbow 0 corresponds to black and white image display.
 Rainbow 1 to 7 corresponds to colorised spectrum.
- ❑ **TI/MI**
 Display/Hide Thermal or Mechanical Indexes.

3.7.3.3 PW Frozen Menu

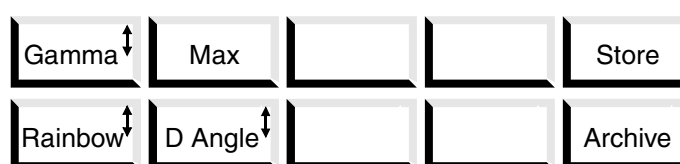

See section PW live menu above for details of items.

See 2D frozen menu in Chapter 3.7.1.3, “2D Frozen Menu”, on page 3-30.

3.7.3.4 PW Doppler Audio Amplifier

SIGMA 330 and SIGMA 110 include a stereo amplifier with associated loudspeakers to amplify Doppler audio signal. Volume is adjustable by rotating the uppermost knob on the left side on the front of the monitor housing.

3.7.4 CW Doppler

SIGMA 110 and SIGMA 330 perform Continuous Wave Doppler (CW) when Doppler option is installed.

Not all of the transducers are CW compatible. See table -i, "Probe applications," on page -xvi for the CW compatible probes.

1. The first time that you press the **CW** key, you enter CW mode, 2D+CW is displayed. The CW line marker is displayed on the 2D image. The trackball allows the user to move the marker on the image to reach the required area.
2. Set the CW line to the desired position. When releasing the trackball the 2D image is automatically frozen and the CW mode becomes active. If the CW line is repositioned by the trackball the 2D image will get unfrozen again. The 2D image is refreshed at the end of each CW sweep. The "Refresh" function can be enabled or disabled in the "Preferences" Menu (**SET UP > Prefs > Display > Refr ON/OFF**).
3. If the user want to get the 2D image active without changing again to CW, press the **SELECT** key. To restart the automatically changing between 2D and CW press the SELECT key again.
4. Press a second time the **CW** key to display a 2D icon/CW format.

3.7.4.1 CW Mode Selection

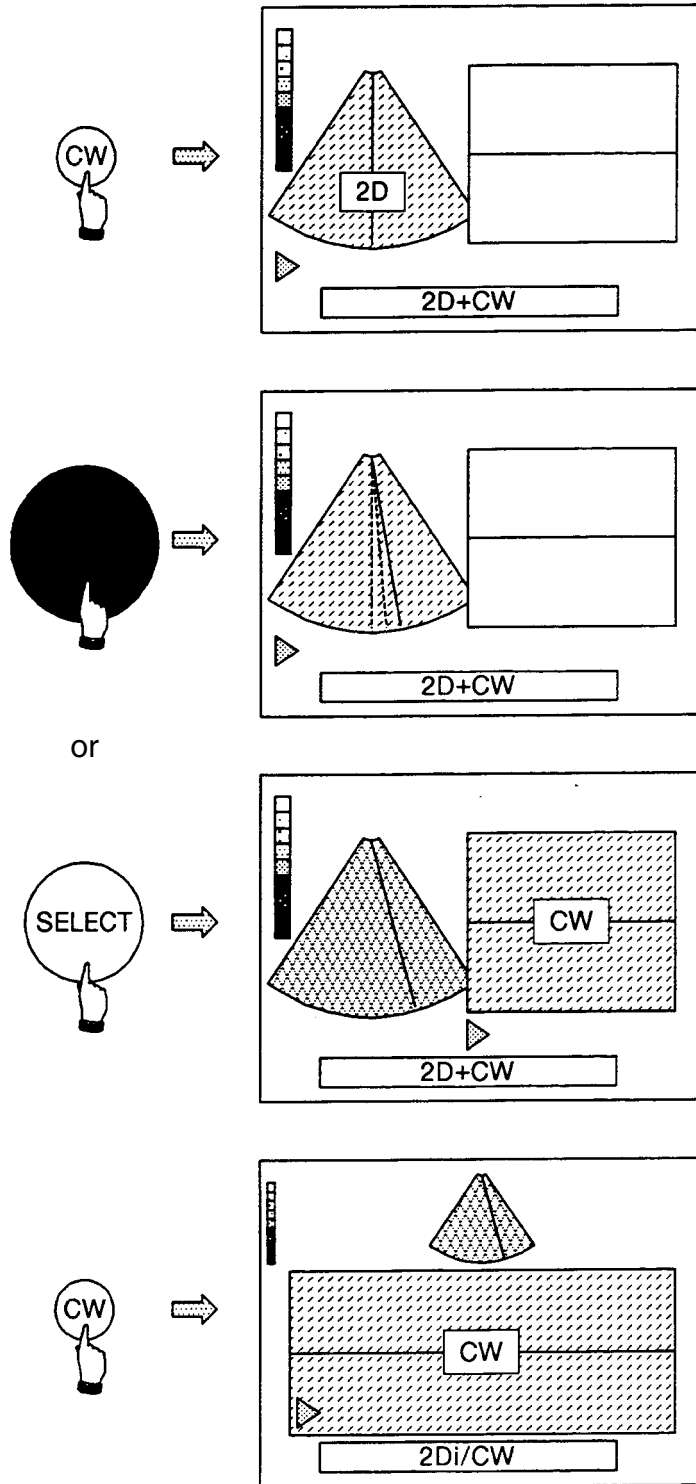
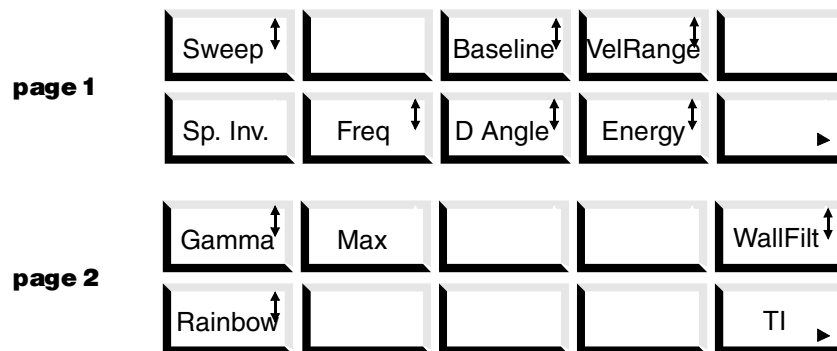

Figure 3-6: CW Mode Selection

3.7.4.2 CW Live Menu

If CW mode is active the following SP menu is displayed on the screen. The 2D image is frozen or refreshed at the end of each SP sweep.



The CW menu is similar to the PW menu except:

- ❑ Gate Size which is not significant in CW Doppler can not be selected.
- ❑ Steering function is not available.

See section PW live menu in Chapter 3.7.3.2, “PW Live Menu”, on page 3-36 for details of the different items.

3.7.4.3 CW frozen menu

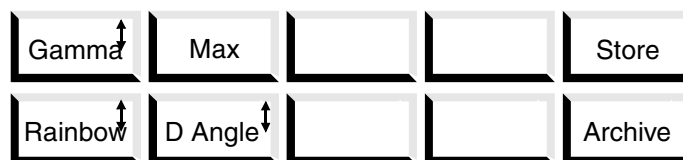

See section PW frozen menu in Chapter 3.7.3.3, “PW Frozen Menu”, on page 3-37 for details of items.

See 2D frozen menu in Chapter 3.7.1.3, “2D Frozen Menu”, on page 3-30.

3.7.4.4 CW Doppler Audio Amplifier

SIGMA 330 and SIGMA 110 include a stereo amplifier with associated loudspeakers to amplify Doppler audio signal. Volume is adjustable by rotating the uppermost knob on the left side on the front of the monitor housing.

3.7.5 CFM Mode

SIGMA 330 can perform Colour Flow Mapping (CFM) when CFM option is installed and CFM compatible probe is used.

See table -i, "Probe applications," on page -xvi for the CFM compatible probes.

Press CFM key to select CFM mode (see figure 1-4, "Keyboard", on page 1-13 to locate the key).

3.7.5.1 CFM Mode Selection

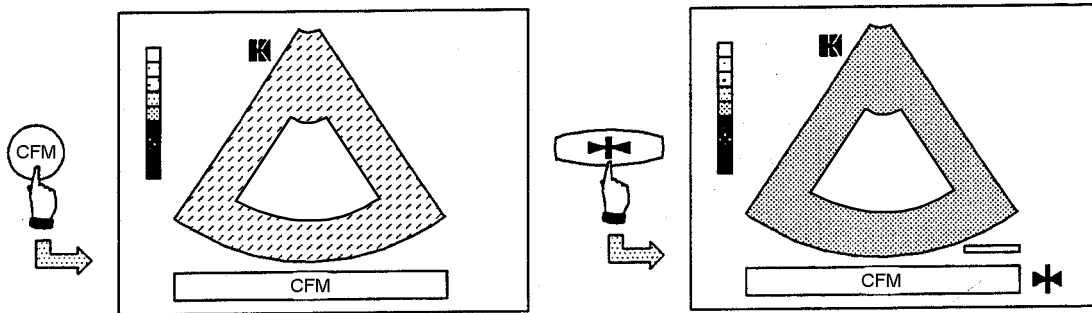

Figure 3-7: CFM Mode Selection

3.7.5.2 Sub-Application Menu

When selecting the CFM mode by pressing the **CFM** key, the sub-application menu is displayed first. The user can select between the different sub-applications for his actual examination. By selecting an appropriate sub-application the optimum parameter set for the application is loaded.



The displayed sub-application menu is dependent on the linear probe which is selected.

The sub-application menu does not exist for Cardio application and the CFM live menu is displayed when pressing the CFM key.

3.7.5.3 CFM live menu

From the previous menu, Sub-Application, press ESC to display the CFM live menu:

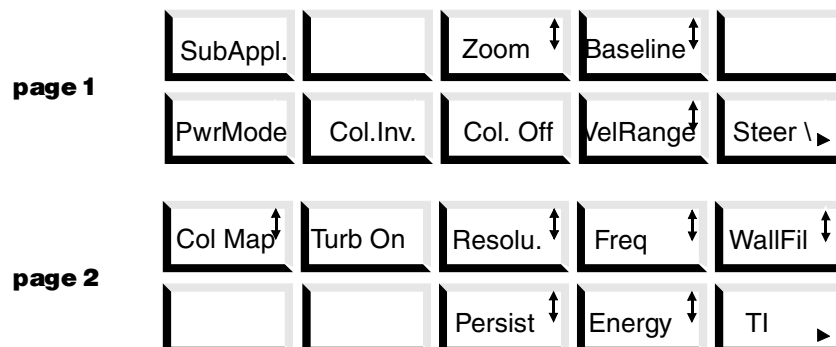

- ❑ **SubAppl.**
This button displays the sub-application menu described in Chapter 3.7.5.2, “Sub-Application Menu”, on page 3-42, to change between the different sub-applications.
- ❑ **Fast/Normal**
In Cardiology, Fast/Normal replaces the SubAppl button. This function modifies the frame rate. Select Normal for a higher sensitivity and Fast for a higher Frame rate.
- ❑ **Baseline**
Pressing this button selects the CFM baseline shift which can be changed with the MP. The actual baseline position is displayed at the left side of the colour scale (see Chapter 1.5.1.2, “Colour/Grey Scale”, on page 1-34). The baseline position can be changed in 25% steps between -100% and 100%.
- ❑ **Pwr/VelMode**
The user can select with the Power/Vel. key between power or velocity mode.
- ❑ **Zoom**
By pressing this button you can enter the Zoom mode.
- ❑ **Col. Off**
This button is used to hide the colour flow data. The mode is changed from CFM to 2D. All of the CFM menu keys are no longer selectable. The 2D menu is displayed including the **Col. On** key to switch back to CFM mode (“Tilt” and “Ad Focus” items are not available when colour is off. See Chapter 3.7.1.2, “2D Live Menu”, on page 3-28 for details).

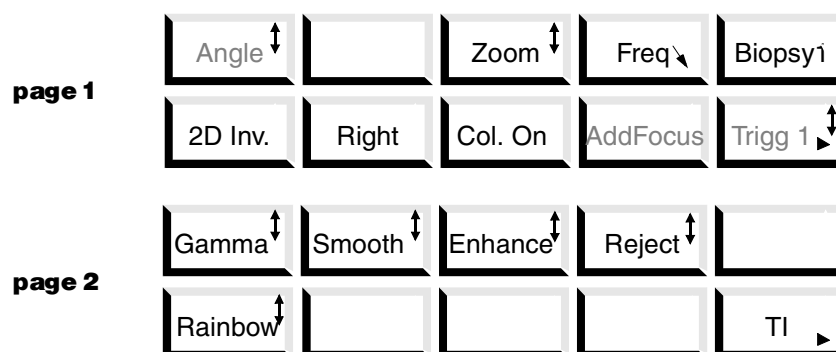

- ❑ **VelRange**
Pressing this button selects the velocity range which can be changed with the MP according to the Doppler frequency.
- ❑ **Steer**
With this button the user can switch between three steering angles, left straight and right. The angle depends on the selected probe and the selected CFM transmit frequency.
- ❑ **Col Map**
Pressing this button selects the colour map which can be changed with the MP. 8 different colour maps are available.
- ❑ **Turb On/Off**
Display or hide the turbulence colour information.
- ❑ **Resolu.**
This key activates the changing of the colour flow resolution with the MP. Three different resolutions are available: Low, Medium and High.
- ❑ **Freq**
This key activates the changing of the Doppler frequency according to the selected probe with the MP.
- ❑ **WallFilt**
This key activates the changing of the wall filter cut-off frequency which can be manipulated with the MP. The selectable cut-offs depend on the actual velocity range.
- ❑ **Col Invert**
Pressing this button toggles between inverted and non inverted colour map.
- ❑ **Persist**
Pressing this button activates the changing of the persistence of the colour pixels on screen.
Three different persistence modes are available with the MP: 0 (no persistence), 1 and 2.
- ❑ **Energy**
Pressing this button activates the increasing/decreasing of the transmit energy. The energy can be adjusted between -21dB and 0 dB in steps of 3dB with the MP. 0 dB corresponds to maximum energy which is smaller or equal to the recommended level for the selected application (see Chapter 1.7.12, “Acoustic Power”, on page 1-51).
- ❑ **TI/MI**
Display/Hide Thermal or Mechanical Index.

3.7.5.4 CFM Frozen Menu

When pressing the **FREEZE** button in CFM live mode, the following menu is displayed on screen:

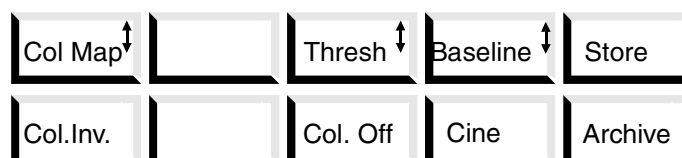

- ❑ **Thresh**
Pressing this key activates the setting of the threshold level between CFM and 2D information in order to select whether the CFM or the 2D information is displayed. For low thresh-

old the 2D information gets higher priority over the CFM information. The Threshold level can be set by the MP.

See CFM live menu in Chapter , “From the previous menu, Sub-Application, press ESC to display the CFM live menu:”, on page 3-43 for function details of the other buttons.

For **Store** and **Archive** function see Chapter 3.11, “Digital Archiving: KIPRISM”, on page 3-51.

The following menu is displayed if colour is off:

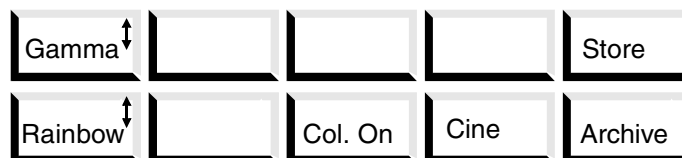

See CFM live menu in Chapter , “From the previous menu, Sub-Application, press ESC to display the CFM live menu:”, on page 3-43 for function details of the buttons.

3.7.5.5 CFM Window

□ **Overview**

The colour flow mapping is related to the CFM Window. The CFM Window is the region of interest where the user wants to display colour information. The wider the CFM window is, the slower the frame rate - with an unchanged velocity range- is. Sizing and moving the CFM window is a simple mean for the user to define the first and the last CFM beam.

□ **Moving and sizing CFM window**

CFM window size and position are changed using the trackball. By pressing on one of the upper two trackball keys, the user toggle the trackball assignment between these two operations. The distinction is made by drawing a sign inside the displaced corner when the CFM window is sized.

□ **Position limitation**

The position of the CFM window is limited in the angular and radial direction (x and y direction for flat probes):

- the CFM window cannot start at depth 0.
- the selected PRF limits the scanned CFM depth. When the user wants to exceed this limit, the PRF is automatically modified.

□ **PRF Auto Adjustment**

As above mentioned, the CFM window position and size is limited by the PRF. When the user wants to exceed this limit, an auto adjustment will be performed: the PRF is set to the next available lower value. The original value is restored as soon as the CFM window is moved to a suitable position.

3.7.5.6 Trackball Assignment

In CFM mode, the trackball is assigned to different actions:

- in live mode
 - resizing of the CFM window
 - positioning of the CFM window
 - moving Cursor pointer

- moving zoomed window in zoomed CFM
- moving TM line in **CFM**/TM
- moving PW gate in **CFM**/PW
- in freeze mode:
 - moving Cine loop
 - moving Cursor pointer
 - moving magnified area

3.7.6 3D imaging

This function uses the internal compact PC, see Chapter 3.20, “Integrated PC (SIGMA 330 Excellence)”, on page 3-110.

- 3D-FetalView™ : for using this software module, please consult its proper user manual.
- 3D-VascularView™ : for using this software module, please consult its proper user manual.

3.8 Print

This function controls the Video Printer. The user can select between 2 print keys:

- Press PRINT 1 function key to print a "screen copy" on the B & W Video Printer
- Press PRINT 2 function key to print a "screen copy" on the Colour Printer or to store the image in the digital archive (equivalent to the Store menu key in FREEZE mode).

See Chapter 3.6.5.4, "System", on page 3-19 for PRINT2 configuration setting.

See Chapter 2.9.2, "Recommended Peripherals", on page 2-17 for recommended Video Printer.

3.9 Cine Mode

The Cine mode is a specific function used to analyse a biological movement. This function allows the user to store, in real time, up to 282 images in the SIGMA 110/330 Memory (with Cine Mode Option installed for SIGMA 110). The tables summarize the number of images or trace screens stored depending on format, medical application and probe.

FORMAT	2D IMAGES			TRACE SCREENS	
	Linear probes/ Convex probes	Annular Sector probes Cardio	AS probes Radio, Vasc, Ob/Gyn	TM	Doppler
	min. - max	min. - max	min. - max		
2D	44 - 282	66 - 130	45 - 92	NA	NA
2D+ TM 2Di+Doppler	37 - 230	56 - 109	38 - 77	5	5
2Di+Doppler	30 - 194	45 - 89	31 - 63	5	5
TM Doppler	NA	NA	NA	16	16

Table 3-9: Cine Mode Memory in 2D

FORMAT	5.0 LV/ 7.5 LVS	7.5 LV	3.5 MC/ 3.5 CV	6.5 VMC	6.5 MC
CFM	52	64	64	52-64	63-64
CFM / TM	44	64	64	44-64	53-64
CFMi / SP	35	60	60-64	35-64	43-64

Table 3-10: Cine Mode Memory in CFM

In CFM mode, the number of images stored depends mainly on the angle of the 2D sector; the number of trace screens stored is the same as in 2D.

These images can be displayed and analysed image by image on the SIGMA 110/330 screen.

This function is always activated for all modes and formats, so the user can easily use it by pressing the FREEZE key and using the trackball to select the images. In dual image formats such as 2D/TM, 2D/PW use the SELECT key to switch between the two cine modes.

3.9.1 Storing Pictures

The system is continuously recording ultrasound images in memory. Press **FREEZE** key to stop the recording.

The last images are stored in the SIGMA 110/330 memory. The latest is displayed on the video screen. The displayed image number is shown at the bottom right of the video screen.

Note

By pressing the FREEZE key again, the previous stored images are overwritten. A new recording is started.

3.9.2 Displaying Pictures

The user can analyse the images previously recorded. The trackball is used to perform either forward or backward review. The displayed image number is shown at the bottom right of the video screen.

3.9.3 Cine Auto-Replay

For each 2D and CFM frozen menu, **Cine** key is displayed. Pressing the **Cine** key displays the **Cine Menu** that allows the user to easily manage the cine replay.

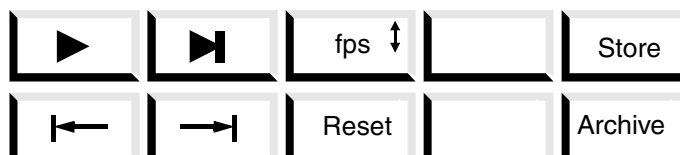

- ▶/■ : play (in the defined limits using the selected frame rate) / stop the current cine sequence. Note that when the cine is played, the cine frame counter is hidden. The corresponding menu key is a two states key, the default action is “play”. Note that the icon representing the next action is always displayed. So, when the cine is played, the stop icon is displayed and vice versa.
- ▶| : play the cine step by step (in the defined limits using the selected step):
- select the start and the end images of the cine replay:



To select the start and the end images of the cine loop sequence, the user selects them using the trackball (the cine loop is in manual mode) and validates his choice by selecting the suitable key.

- reset the start and end image selection using the **Reset** key. The complete cine loop sequence can then be played.
- define the number of frames per second (fps) displayed during the cine replay using the **fps** key. This key is an incremental key and the frame rate replay is changed using the incremental pot. The frame rate of the cine replay is always lower or equal to the acquisition frame rate and has to be chosen among the following values: 1, 2, 4, 6, 8, 12, 16, 25 fps. The default value is 12 fps when this value is possible else 1 fps is selected.
- store the selected image on a SRAM flashcard using the **Store** key.
- review the images stored on a SRAM using the **Archive** key.

3.10 Magnifier in 2D and CFM Mode

Press **MAGNIFY** key to magnify the image displayed on the screen.

Use the trackball to move and select the portion of the image to be displayed.

In 2D/CFM mode use the upper left select key of the trackball to switch between moving magnified image and moving CFM window if magnifying is active.

Press **MAGNIFY** key once more or 2D to return to the normal format.

The graphic symbol below shows that the image is magnified:



The magnification function works equally well on live images and frozen ones.

NOTE

Magnify can use a zoom factor up to 6 dependent on the different probes.

3.11 Digital Archiving: KIPRISM

The SIGMA 110 and SIGMA 330 systems include the **KIPRISM** features which allows the user to store ultrasound images, report and patient information on Memory Cards (SRAM flash cards).

The KIPRISM logo is displayed on the bottom left of the SIGMA Start-up screen.

KIPRISM allows displaying and storing images in thumbnail format as well as full screen format on a memory card. The memory card can be read by any PC equipped with a recommended PCMCIA driver, refer to Chapter 2.9.3, "Archiving on Personal Computer", on page 2-17.



All selections can be done with the trackball and the three associated SET keys.

KIPRISM features:

- ❑ report printout.
- ❑ user interface for images: multi patient environment, multi images (Thumbnails presentation) with calibration information, image storage and restore from memory cards.
- ❑ user interface for report: store report and patient information. Display report preview and report sheets from the memory card.
- ❑ DICOM compatibility.
- ❑ used for EasyPrint: printing images with connected inkjet printer.

3.11.1 Image Storage and Freeze Menu

STORE and ARCHIVE functions are available from every freeze menu in all modes.

Press **FREEZE** key to display the following menu:

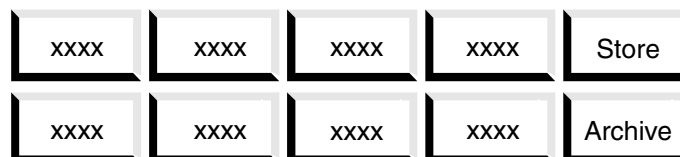

- ❑ The **STORE** key stores the current image, displayed on the SIGMA screen, in the memory card. This key is automatically disabled if there is no space left on the memory card or if the memory card does not use the KIPRISM format.
- ❑ The **ARCHIVE** key enters the archive mode. This key is automatically disabled if no data are stored in the memory card, if the memory card does not use the KIPRISM format or no card is inserted.
- ❑ The **PRINT 2** key of the user interface can be configured to store images on memory cards. In the setups, the user can select the action of this key: print on a colour video printer or save on the memory card. If the KIPRISM option is enabled, the default action is set to the image storage on memory card.
If the PRINT 2 key is associated to the memory card:
 - The user can save images when the machine is in LIVE mode.
 - A beep will be generated if there is no space left on the memory card, if the memory card does not use the KIPRISM format or no card is inserted.

If the memory card format is not valid, a dialogue box offers the possibility to format it. For formatting a memory card, refer to Chapter 3.6.6, "PCMCIA CARD", on page 3-23.

To store an image on a memory card:

1. Insert the memory card in the dedicated slot on the right side of system. Put the card in the slide guide, respecting the connection direction (label side up), and push it gently up to the connector stop.
2. Press **FREEZE** key
3. Press **Store** key

If the PRINT 2 key is associated with storing pictures on memory cards, you can directly press the **PRINT 2** key to freeze the screen and store the picture on memory card.

3.11.2 Archive: Display of Stored Images

3.11.2.1 Panels of 16 Images

Pressing **Archive** displays the archive menu and a screen layout divided in 16 locations dedicated to insert the images stored on the memory card.

The image selected by default is the last one stored. The border of the selected image is highlighted (in yellow for SIGMA 330).

For selecting an image use the trackball.

Each image can be named by the user.

The title of the selected image is automatically displayed between the menu and the bottom of the panel.

A set of 16 images can be displayed; this consists of an images panel. When more than 16 images are stored, more than one panel exists.

Press one of the upper SET key of the trackball to invoke the full screen display mode; the selected image is displayed.

3.11.2.2 Menus

The labels of the menu are automatically updated when the user changes the trackball assignment, but the actions associated do not change:

- The first key ▲ selects the previous panel of items (patients or the thumbnails). This key is disabled for the titles or if only one panel exists for the thumbnails.
- The second key ▼ selects the next panel of items (patients or thumbnails). This key is disabled for the titles or if only one panel exists for the thumbnails.

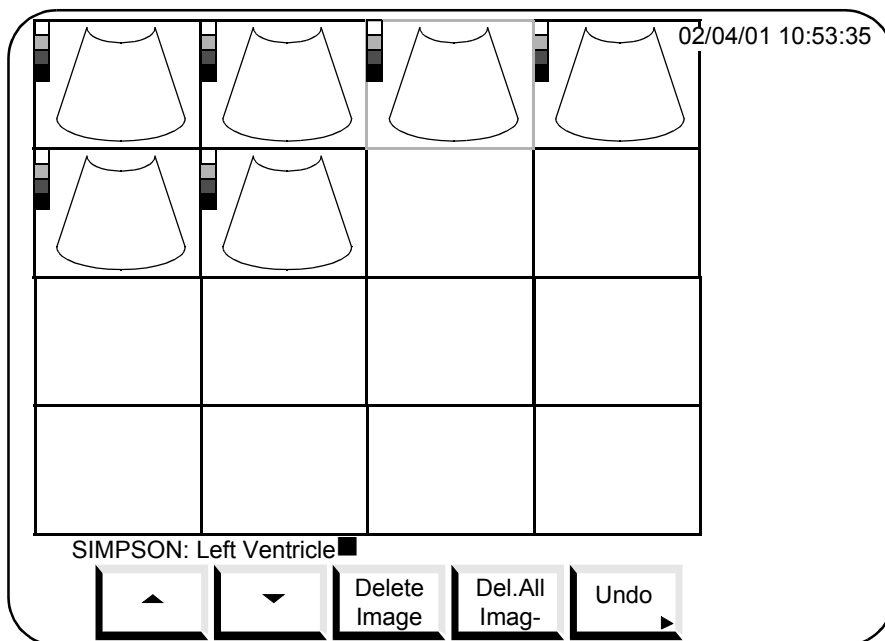

- ❑ The third key is used to delete the current selected item (patients, titles or thumbnails). When the user presses it, a dialogue box appears for a confirmation (not for the title).
- ❑ The fourth key is used to delete all items of the selection (patients, titles or thumbnails). When the user presses it a dialogue box appears for a confirmation.
- ❑ The fifth key is used to undo the deletion of items. It restores all deleted items, it is not an “undo action”. This key is not available for the titles. This key is disabled if no items have been deleted.

This menu is available when the selection is assigned to the thumbnails:



This menu is available when the selection is assigned to the Titles.



3.11.2.3 Principles of Selection and Validation

- ❑ The three **SET** keys change the assignment of the **trackball**. The trackball can be assigned to the image list, or to the title (to change the position of the character cursor), or to the list of patients.

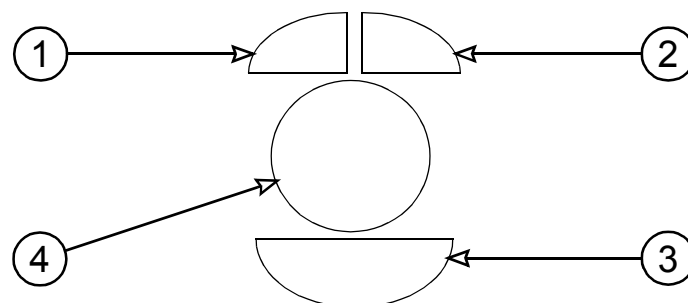

- ❑ The **UPPER SET** keys ① ② :
 - If the trackball is assigned to the thumbnails, it opens the selected images in full screen mode.
 - If the trackball is not assigned to the thumbnails, it assigns the trackball to the thumbnails and validates the current selection i.e. the patient selected or the title selected.
- ❑ The **BOTTOM SET** key ③ :
 - If the trackball is assigned to the title, it validates the new title, and assigns the trackball to the thumbnails. (like the UPPER SET key).
 - If the trackball is not assigned to the title, it assigns the trackball to the title.
- ❑ The **TRACKBALL** ④ : To choose an image, a patient or character in the title.
- ❑ The **ENTER** key: Can be used to validate the title, instead of the UPPER SET key or the BOTTOM SET key.

3.11.2.4 Full Screen Display

In this mode the image selected is displayed in its normal size.

The image stored is independent from the video format (PAL or NTSC), but it depends on the original screen colours (B/W or Colour).

The title of the image is displayed at the bottom of the image, above the menu and can be modified as explained before.

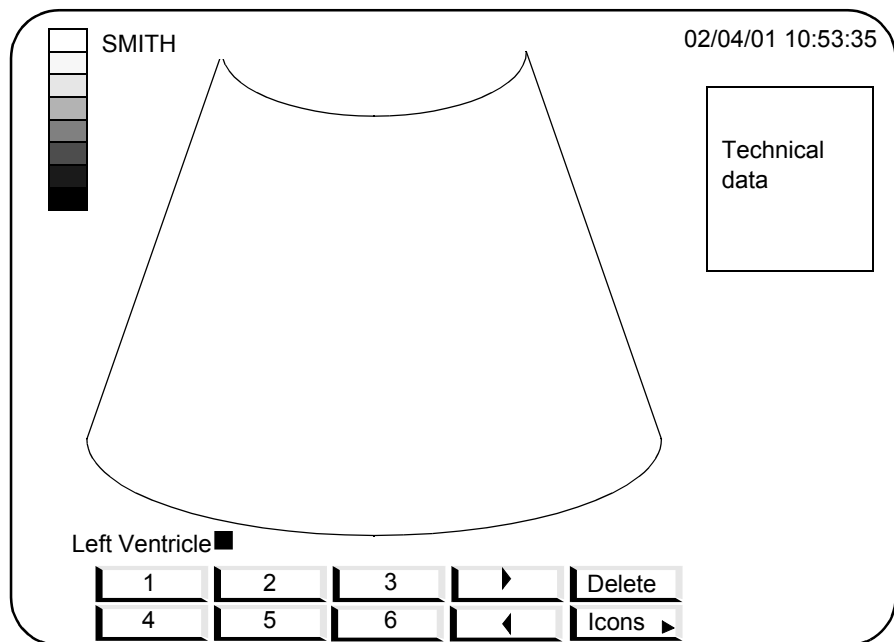

- The **Keys 1 to 6** select the corresponding image index.
- The **▶** key selects the next image found in the list. The menu is automatically updated. If only one image is stored, this key is disabled.
- The **◀** key selects the previous image found in the list. The menu is automatically updated. If only one image is stored, this key is disabled.
- The **Delete** key deletes the image. A dialogue box appears for a confirmation. If the user chooses Ok, the image is deleted and the program returns automatically to the thumbnails mode. After this action, the UNDO key is enabled.
- The **Icons** key returns to the image panel mode.

3.11.2.5 Exit Archive mode

- The keys allowing to quit this mode are: ESCAPE, FREEZE and PROBE.
- The POWER_OFF key is always enabled.
- When the user exits this mode all deleted items are definitely erased and lost.

3.11.3 Using the Memory Card on PC

The memory card can be used on a standard Personal Computer equipped with a PCMCIA card reader. See Chapter 2.9.3, "Archiving on Personal Computer", on page 2-17 for recommended PCMCIA card adapter.

With KIPRISM, image files (.PCX) and report files (.TXT) can be saved on a SRAM via the SIGMA PCMCIA drive. These files can be read directly on a PC via its PCMCIA drive using an image editor for image files and a text editor for reports.

File name consists of 8 characters for the actual name, plus 3 characters for the file name extension.

The name (8 characters) is split into two parts:

- the six first characters are based on the patient name or the image title as shown below:

Patient name	Image Title	File name of image files	File name of report files
Not defined	Not defined	Default name ^a	Default name ^a
Defined	Not defined	Patient name ^b	Patient name ^b
Not defined or Defined	Defined	Title ^c	

- a. IMAGE or REPORT.
- b. 6 first characters of the patient name (completed if necessary by “_” characters).
- c. 6 first characters of the title (completed if necessary by “_” characters).

- the two last characters are reserved for the number of the image or report (e.g. “01”, “02”, “03”... “99”).

3.11.4 Patient Report and Patient ID with KIPRISM

The  icon is used to store the current state of the report. For details on the different icons see Appendix B, “Report Menu”, on page 7-5.

3.11.4.1 Ob/Gyn Medical Application Report Menu

This menu is available on the Report when the medical application Ob/Gyn is chosen:

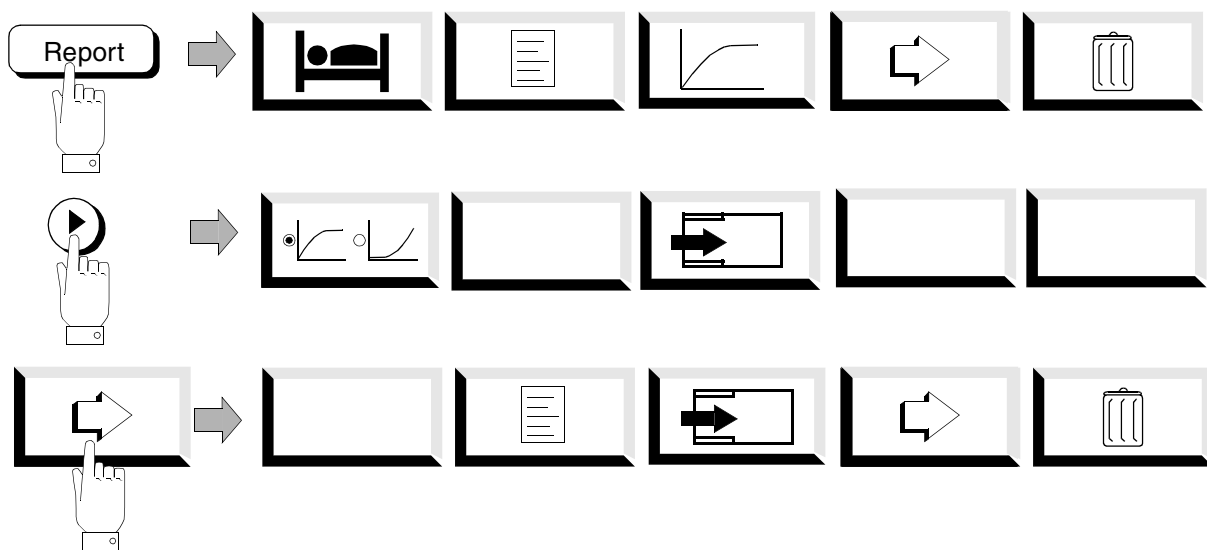

The **STORE** key doesn’t save the current medical application or the current page displayed, but saves all valid measurement in all medical applications.

3.11.4.2 Vasc., Cardio and Radio Medical Application Report Menus

This menu is available on the Report when the medical applications Vasc., Cardio or Radio are chosen:



The **STORE** key does not save the current medical application, but save all valid measurement in all medical applications.

3.11.4.3 Report Print Preview menu

This menu is available on the Report in Print Preview mode:



3.11.4.4 Patient and Study Information

This menu is available when the user enters Patient ID:

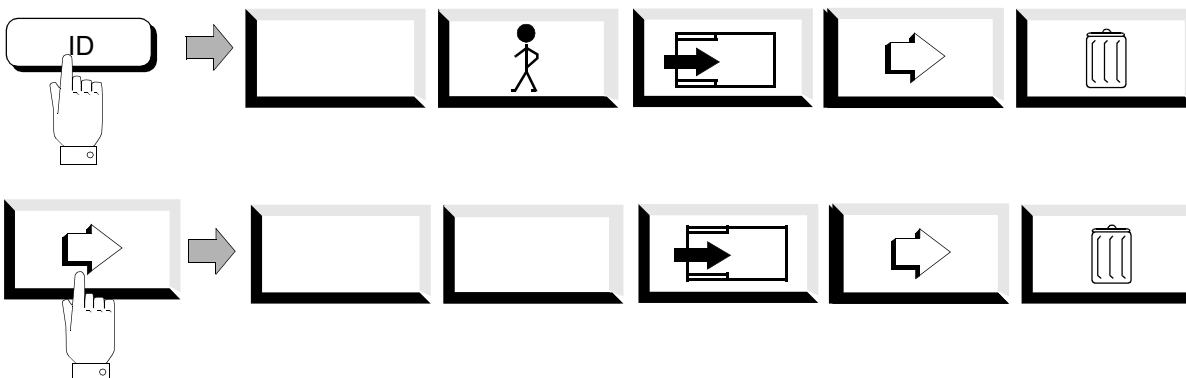

The **STORE** key will create a new patient file on the memory card if the user has pressed the new patient key, else it will modify the last patient saved. Each time the STORE key is pressed, a dialogue box appears for a confirmation. To avoid confusion, a unique identifier is created internally for each patient.

3.11.4.5 Reports

As above mentioned (Chapter 3.11.2.1, “Panels of 16 Images”, on page 3-52), the mode entered when pressing on the “Archive” key of the Freeze menu is the “Thumbnails” mode and the corresponding menu is displayed. To select the “Report Archive” mode, press on MENU NEXT; the screen is changed as shown below: a popup menu is displayed on the right showing all reports present on the flashcard and the key information stored in the selected report text file is displayed on screen.

FILE: SMITH.TXT
 CREATED: 19/11/97 10:01:54
 SIZE: 8.38KB
 PAGES: 13

PATIENT INFORMATION

Laboratory.....: SAINTE-ANNE
 Physician.....:
 Operator.....: MH

PATIENT REFERENCES

Patient name.....: SMITH
 Address.....:
 Phone number.....:

27/04/00 10:53:35

↑

REPORT01.TXT
 REPORT03.TXT
SMITH.TXT
 WESSON.TXT

↓

Delete Report

Del.All Reports

Undo

- The third menu key is used to delete a report. When the user presses it a dialogue box for confirmation is then displayed and the report text file is deleted if the user selects “Yes”.

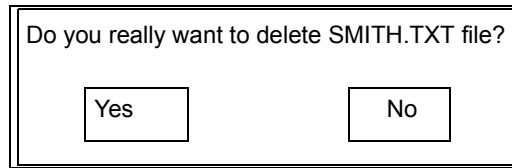

- The fourth key is used to delete all reports stored on the flashcard. When user presses it a confirmation dialogue is displayed (“Do you really want to delete all reports? Yes/No”).
- The fifth key is used to Undo the deletion of reports. It restores all deleted reports. This key is disabled if no items have been deleted.

Remark: the Undo action is impossible after Archive mode exit.

3.11.4.6 Patient

As above mentioned (Chapter 3.11.2.1, “Panels of 16 Images”, on page 3-52), the mode entered when pressing on the “Archive” key of the Freeze menu is the “Thumbnails” mode and the corresponding menu is displayed. To select the “Patient Archive” mode, press on MENU PREVIOUS; the screen is changed as shown below: a popup list containing all the patients present on the flashcard is displayed on the right and the information for the selected patient is displayed on the left.

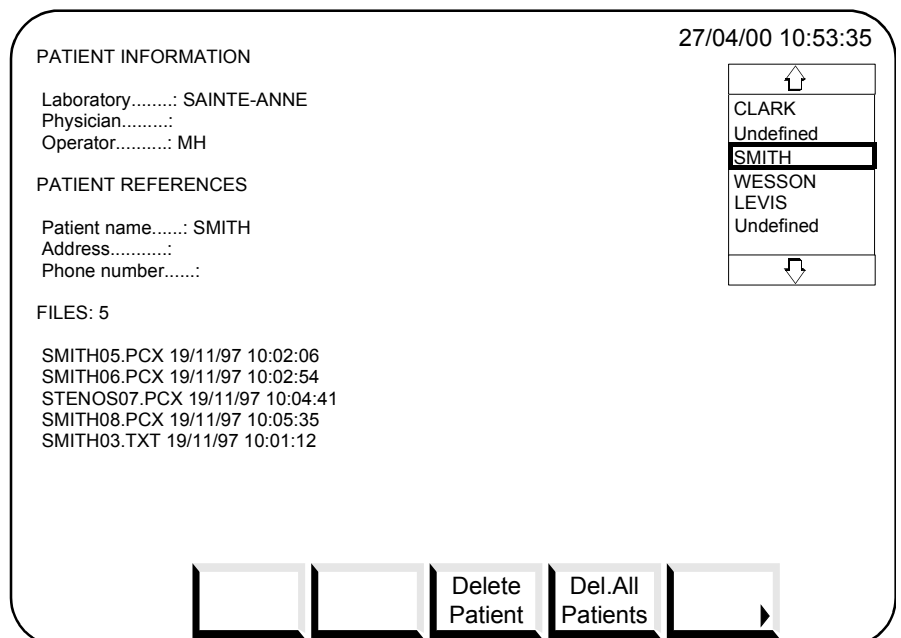

- The third menu key is used to delete a Patient (ALL information relative to a patient). When the user presses it, a dialogue box for confirmation is then displayed.

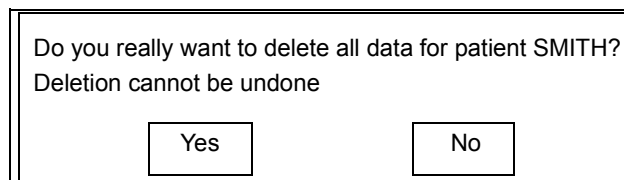

- The 4th menu key is used to delete all data for all patients stored on the flashcard. When the user presses it a dialogue box appears for a confirmation “Do you really want to delete all data for all patients? Deletion cannot be undone. Yes/No”. With “Yes” the SRAM is formatted.

3.11.4.7 Battery State

When the user plugs a SRAM with a low state battery, a warning message is displayed to inform the user.

If this message appears, the user should change the battery. The operation is described by the SRAM manufacturer. After, this operation, the user must verify the format of its SRAM on the PC and on the SIGMA. If the SRAM is no more formatted, the user must format it again on the SIGMA.

3.12 Annotations

The **ANNOTATE** key displays the ANNOTATION Menu. This menu is used to write annotation, labels or arrows on the screen.

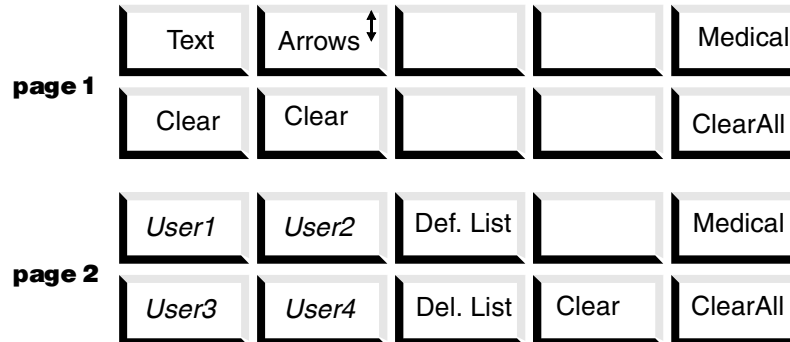

Note: Menu items links to F1, F2, F6 and F7 keys contains the reference to lists defined by the user. In this document, these 4 lists are called *User1*, *User2*, *User3* and *User4*. These four fields are empty, when they contains no reference to a list (e.g. first use of the sigma).

3.12.1 Entering Annotation Mode

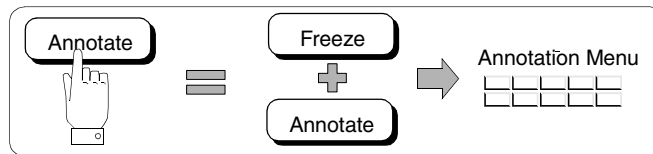

According to the last selected page of this menu, the first or the second page is displayed.

3.12.2 Exiting the Annotation Mode

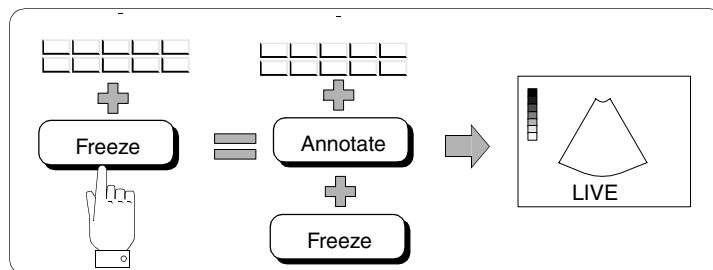

3.12.3 Manual Text Annotation

When the user enters the annotation menu, the manual text entry mode is selected by default (if the page, which contains this menu item, is displayed). To activate it (after an arrow annotation for instance) press on the Text key. To write text on screen, the user puts the calliper (trackball cursor) at desired position and enters text by using alphanumeric keys

The number of text annotations is limited to 20.

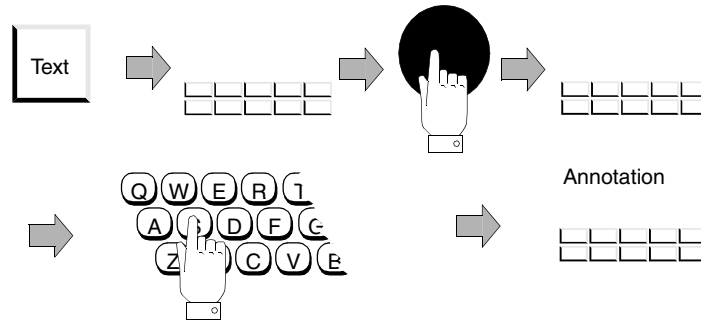

To delete a part of annotation, place the cursor on the area to be deleted using the trackball and press **Backspace** key (⇐).

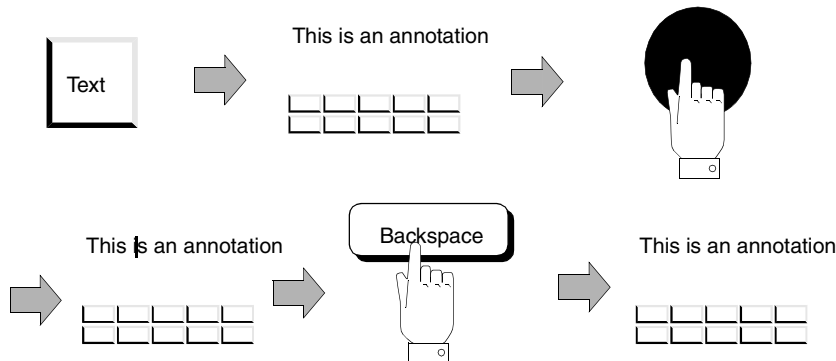

To delete the entire text select **Clear (Text)**.

To validate the text press **ENTER** (line feed is performed) or move the trackball for a new location or press **Text** (or **ANNOTATE** to exit)

3.12.4 Labels

From the main ANNOTATION Menu, the user can enter predefined text (Labels).

3.12.4.1 Create a Label List

The user can create up to 4 labels lists for each Medical Application; each label list can include up to 100 labels, but the entire number of labels is limited to 100.

1. Press **Annotate** key and MENU NEXT to display the LABEL Menu.

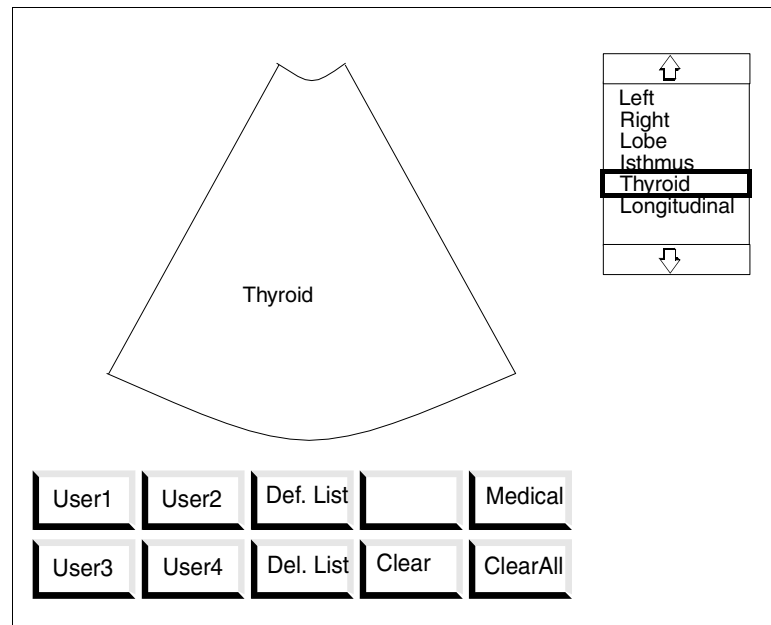

2. Press **Def.Lst** (Define List) key.

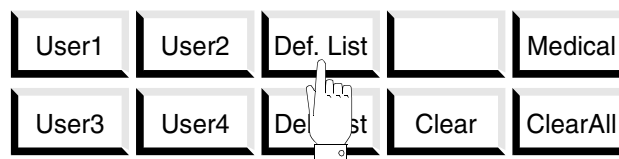

3. Pressing **New list**, displays a dialogue box "List name"



4. Enter the list name: ... [ex: Cardio 1, (max. 8 char.)], then press **ENTER**.

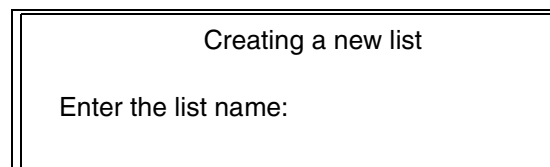

The new list name appears in the list menu and a window is displayed on the top right of the screen.

5. Enter the labels in the window using the keyboard (14 char. max/label), then press **ENTER**.
6. Press **Def.Lst** to end the new list

3.12.4.2 Delete a Label List

1. Press **Del.List**

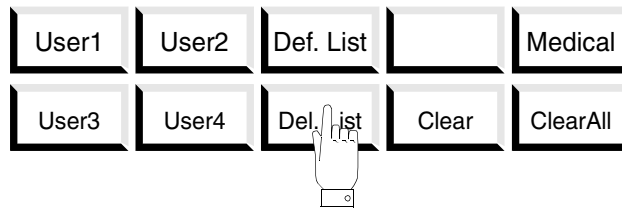

2. Select the list to be deleted



3. Confirm in the dialogue box: Yes or No

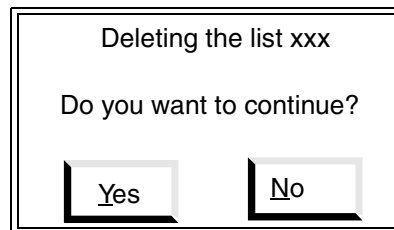

3.12.4.3 Renaming a User Label List

1. To rename a user label list, the user should press on the F3 key (**Def. list**) in the Annotation menu.



2. To rename one of the list, the user presses on the corresponding function key and enters the new name.

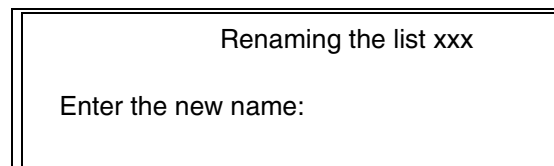

On the label menu, the current name is automatically updated.

Remark: The number of user label list is limited to 4 for each medical application.

3.12.4.4 Label List

The size of the labels should be less than (or equal to) 14 characters. At the same time, only 6 labels can be displayed in the list box. If the label list is greater than 6 labels, only the first 6 ones are displayed. Arrows (scrolling Up/Down Arrow) are displayed on the top and on the bottom to scroll the list (page scrolling).

❑ **Adding and deleting user labels**

To add user labels in the current label list, the user selects the empty field at the end of the list (by pressing on the upper left trackball key or any alphanumeric key) enters its new label and validates this label by pressing on the <ENTER> key.

To delete a label, select it and press on the <BACKSPACE> key, the complete label will be removed.

❑ **Moving the label list Up/Down**

By moving the trackball the user puts the focus rectangle on the scrolling Up or Down arrow. When the focus rectangle is on the scrolling Up (Down) Arrow, the list scrolls up (down) automatically by step of one page until the beginning (end) of the list is reached).

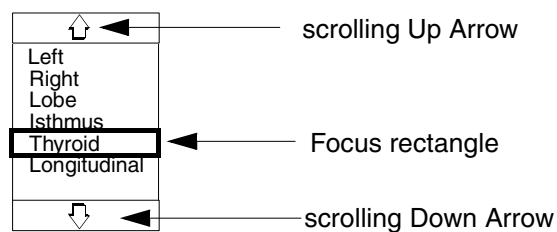

3.12.4.5 Changing Current Displayed List

By using the function keys (F1, F2, F6, F7), another label list is selected. On the right part of the screen the current displayed label list is replaced by the new one.

3.12.4.6 Displaying a Label on the Ultrasound Image

The user selects a label by moving the trackball up or down and validates it by pressing on the upper left trackball key. A rectangle is displayed on the ultrasound image, the user moves it to the desired place. By pressing on the upper left trackball key, the user fixes the label at the current position.

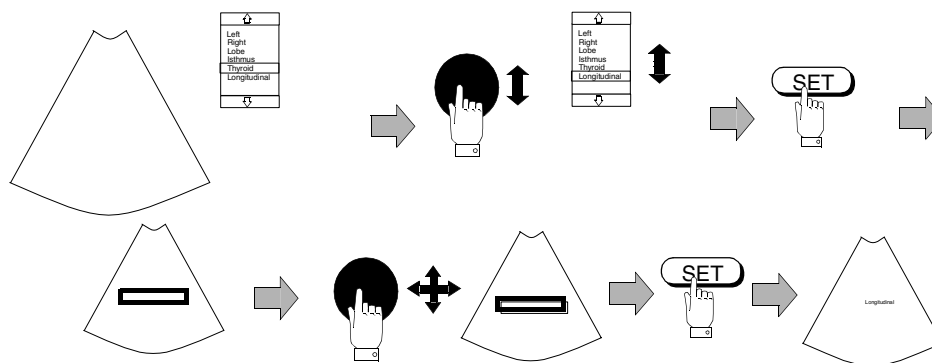

3.12.4.7 Erasing Labels

❑ **Clear label**

By pressing on the Clear key, the user will erase the last displayed label.

❑ **Clear all labels**

By pressing on the Clear all key, the user will erase all the displayed annotation (labels, texts, arrows and body marker).

Remark: Labels are identical to text annotation, so in the preference menu you can choose between keeping text and labels when unfreezing or not. See Chapter 3.6.5.2, “Display”, on page 3-15, issue Annotation for details.

3.12.5 Arrows

Selecting **Arrows** in the ANNOTATION Menu displays an arrow on the left side of the screen. Use the trackball to move the arrow anywhere on the screen and the softpot to change its orientation (8 positions are available). It is possible to display up to 20 arrows anywhere on the screen.

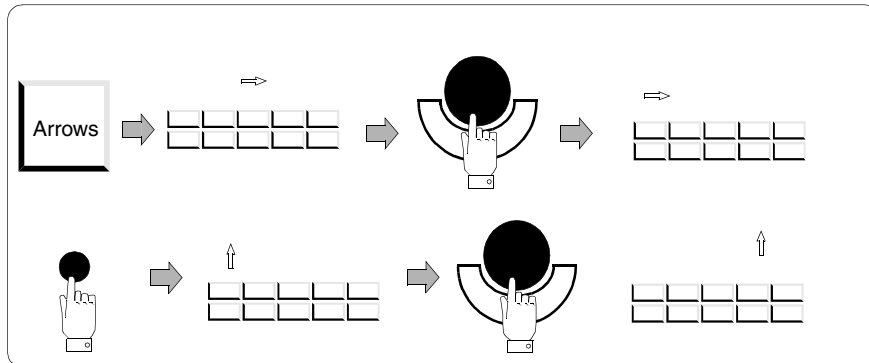

To delete an arrow select **Clear (Arrow)**.

3.13 Body Markers

A set of body markers is available for each medical application. The body markers are used to annotate the ultrasound image. They show the examined part of the body.

The orientation marker shows the scan plane. For Cardiology, there is no orientation marker; the body marker shows the plane itself.

The body markers are accessible from the main ANNOTATION Menu and FREEZE Menu.

3.13.1 Displaying Body markers

To display the body markers:

1. Press the **Body Marker** key to display the Body Marker Menu.

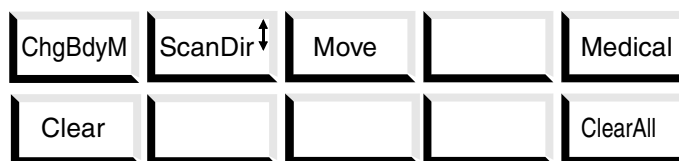

2. Select the desired BODY MARKER in the scrolling list, using the trackball then press Upper SET key. The Body Marker is displayed in the bottom right corner of the selected image.

To scroll the body marker list, the user puts the focus rectangle on the scrolling Up or Down arrow. When the focus rectangle is on the scrolling Up (Down) Arrow, the list is automatically scrolling up (down) in order to select other available body markers.

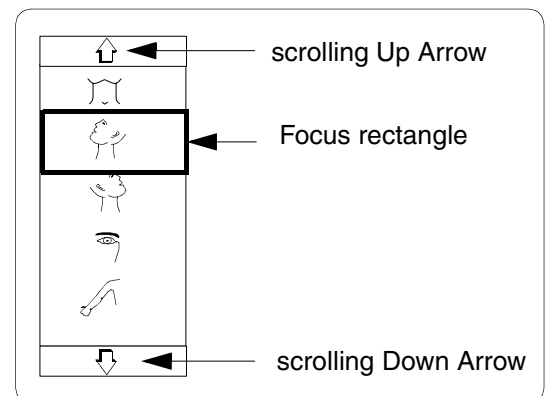

3. Use the Trackball to move the scan direction marker and/or Use MP potentiometer to modify the orientation of the scan plane marker (except in cardiology application) then press Upper SET key.

The angle of the marker can vary from -75° to $+75^\circ$, by step of 15° .

4. Press **ESCAPE** to exit the BODY MARKER Menu.

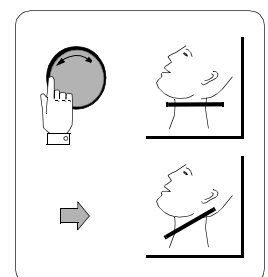

3.13.2 Moving Body Markers

In Dual, Quad and Archive mode, the Body Markers can be moved anywhere on the selected image.

To move the body markers:

1. Press the **Move** key.
2. Select the desired image using the SELECT key.
3. Move the marker using the Trackball.
4. Then press Upper SET key.

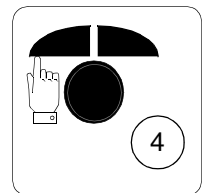
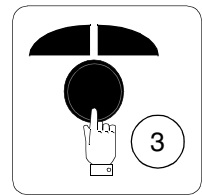

3.13.3 Deleting Body markers

To delete the body markers:

Selecting **Clear (Body Mrk)** erases the last Body Marker.

Selecting **ClearAll** clears the screen of all Body Markers and all annotations.

Different body markers are available in the different medical applications (see Chapter 3.13.4, "Medical", on page 3-66 and Appendix L, "Body Markers", on page 7-111)

3.13.4 Medical

Selecting **Medical** in the ANNOTATION Menu displays the Medical Application menu:

The user can select one of the Medical Applications: Ob/Gyn, Radio, Vasc. and Cardio. The corresponding set of Body Markers will be available. The Medical Application menu can be accessed from Study sheet by selecting "Medical Application" icon.

Note that the setting parameters of the operating probe are not affected by this change.

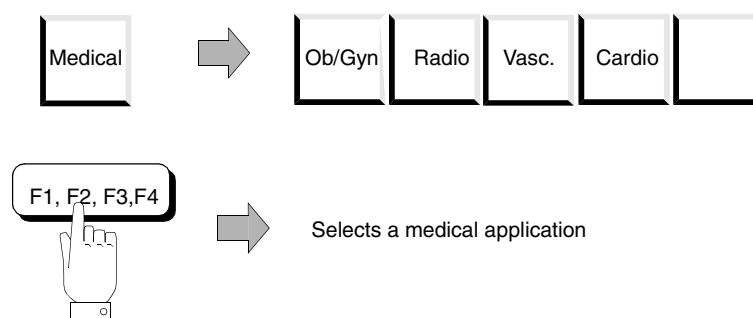

3.13.5 Deleting All Annotations

Select **ClearAll** to clear the screen of all annotations.

3.14 Measurements

Measurement can be made on any image. Callipers are available from 2D-Mode, TM-Mode, Doppler spectrum and CFM to measure distances, areas, angles, times, slopes, velocities, etc. The results are automatically displayed on the screen. Up to ten results of the most recent measurements can be displayed on the right side of the screen.

3.14.1 Generalities

3.14.1.1 Entering the Measurement Mode

To enter the measurement mode press the **MEASURE** key.

The MEASURE Menu is displayed on the screen and ultrasound image is frozen.

3.14.1.2 Quitting the Measurement Mode

Press **FREEZE** key to quit the MEASUREMENT mode and return to live image of the current imaging mode.

Press **MEASURE** key to quit the MEASUREMENT mode and return to frozen image of the current imaging mode.

3.14.1.3 Validation Keys

Generally the trackball is used to move something on the screen. The trackball is joined with two validation keys (upper trackball keys); one or the other have the same function. These keys are named **SET** in the following description.

The trackball and attached keys are used to perform measurements.

3.14.1.4 Other Useful Keys

- ❑ Undo Soft Key
With the **Undo** key the user can delete one by one the different measurements he has made (last in, first out).
- ❑ Escape Key
The **ESCAPE** key (**ESC**) can be used to abort the current measurement. When using this key the system returns to the measurement menu.
- ❑ Backspace Key
The **Backspace** key (↵) in the alphanumeric keypad can be used to erase the last point, for example, when tracing an area contour.

3.14.1.5 Result Display

Measurement results are displayed on the right side of the screen, just under the technical data. Ten result lines could be displayed at the same time. The results are displayed from the top to the bottom. Each displayed result contains: the order number of the result, the type, the value and the unit.

3.14.1.6 Including Measurement in Biometry Study

When a measurement has been made in the measurement mode, the result can be integrated in the biometry study. For this, press REPORT key, the current biometry page is displayed; then select the desired field by moving the cursor with the trackball and valid with SET key.

Note

The report must be entered from measurement mode to allow inclusion.

3.14.1.7 Formulas of the Displayed Measurements

For details about the formulas which stand behind the displayed measurement see Chapter 7, "APPENDICES", on page 7-1.

3.14.2 Starting a Measurement

1. Press **MEASUREMENT** key to enter Measurement Mode. The measurement menu is displayed on the screen and the ultrasound image is frozen.
2. Use the function keys to select the desired measurement.
3. Use the trackball to move the cursor to the desired position.
4. Press **SET** key (upper left trackball key). The value is automatically displayed on the screen (example: velocity) or the second cursor appears for the measurement which needs several cursors (example: distance, area, etc....).
5. Press **SET** key (upper left trackball key) to perform one more measurement of same type or press a menu key to make another measurement.
6. Select **Undo** in the measurement menu to erase the most recent measure.
7. Press **FREEZE** key or **MEASUREMENT** key to quit Measurement Mode.

3.14.3 2D Measurement

If you press on MEASUREMENT key, SIGMA 110/330 displays the following menu:

- in 2D-mode

Distance	Area	Ellipse	Angle	
			Ratio	Undo

- In dual 2D and Quad 2D

Distance	Area	Ellipse	Angle	Volume
			Ratio	Undo

□ in [2D]/SP :

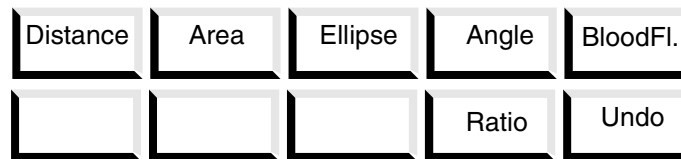

Note

Distance is automatically selected when entering Measurement mode.

3.14.3.1 Measuring a Distance

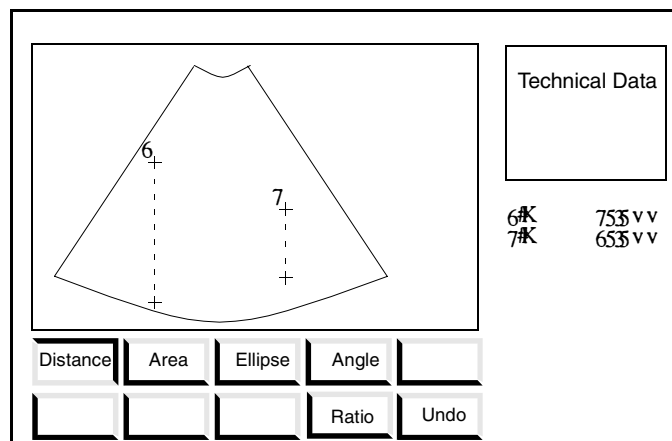

1. Press **F1 (Distance)** to select distance measurement (Distance is automatically selected when entering Measurement mode).
2. Use the trackball to move the first marker to the desired position.
3. Press **upper left SET** key to fix the marker; the second end marker is now available.
4. Use the trackball to move the second marker to the desired position. A dotted line appears to show the position of the distance measurement.
5. Press **upper left SET** key. The result is automatically displayed on the screen. The dotted line stays if the preference "doted line" has been selected in the set up preference menu. The doted line disappears if the preference "no doted line" has been selected in the set up preference menu.

During the measurement, the user can delete a part of the current measurement by pressing on the **BACKSPACE** (↵) key.

Distance results are always in millimetres.

3.14.3.2 Measuring an Area

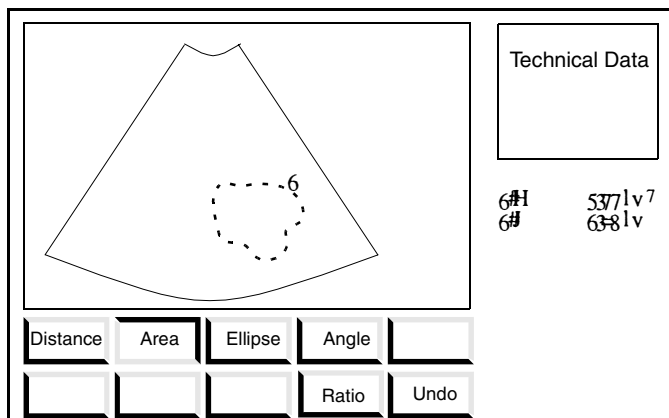

1. Press **F2 (Area)** to select area measurement.
2. Use the trackball to move the first marker to the desired position.
3. Press **upper left SET** key to fix the marker; the second marker is now available.
4. Use the trackball to move the marker and draw the area.
5. there are two ways of finishing the measurement:
 - Press **upper left SET** key. The result is automatically displayed on the screen.
 - Return on the start point of the area measurement, when the two markers are superposed the area measurement is ended.

During the measurement, the user can delete a part of the current curve by pressing on the **BACKSPACE** (↵) key.

For this measurement, two results are displayed: the area in square centimetres and the circumference (perimeter) in centimetres.

3.14.3.3 Measuring an Ellipse

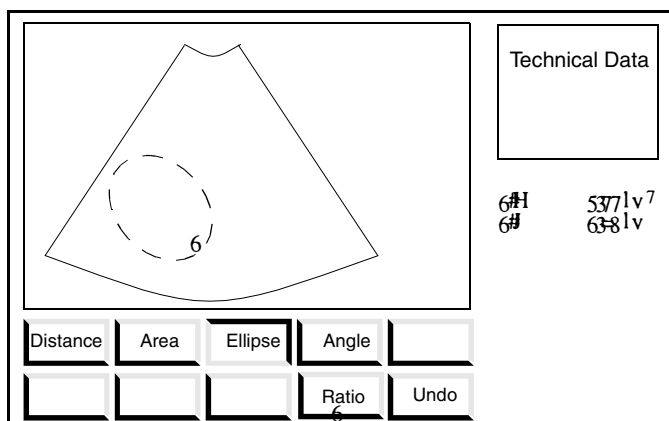

1. Press **F3 (Ellipse)** to select ellipse measurement.
2. Use the trackball to move the first marker to the desired position.
3. Press **upper left SET** key to fix the first marker; the second marker is now available.

4. Use the trackball to move the marker and define the length of the first axis.
5. Press **upper left SET** key to fix the first ellipse axis; an ellipse is now displayed.
6. Use the trackball to modify the ellipse shape; superpose the ellipse and the element to be measured.
7. Press **upper left SET** key to finish the measurement. The result is immediately displayed on the screen.

For this measurement, two results are displayed: the area in square centimetres and the circumference in centimetres.

3.14.3.4 Measuring an Angle

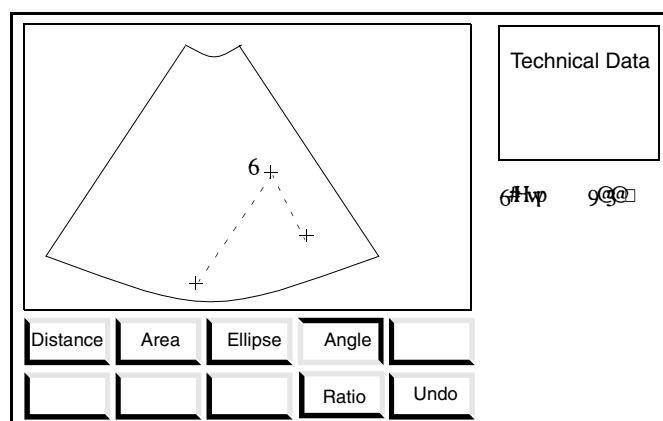

1. Press **F4 (Angle)** to select angle measurement.
2. Use the trackball to move the first marker (angle vertex) to the desired position.
3. Press **upper left SET** key to fix the marker; the second end marker of the first angle side is now available.
4. Use the trackball to move the second marker to the desired position.
5. Press **upper left SET** key to fix the first angle side; the second end marker of the second angle side is now available.
6. Use the trackball to move this marker to the desired position.
7. Press **upper left SET** key to fix the second angle side. The result is automatically displayed on the screen.

Angle is always displayed in degrees.

3.14.3.5 Volume

The volume measurement is composed of three distance measurements: height and width distance measurements on the first 2D pad and depth distance measurement on the second one, or vice versa.

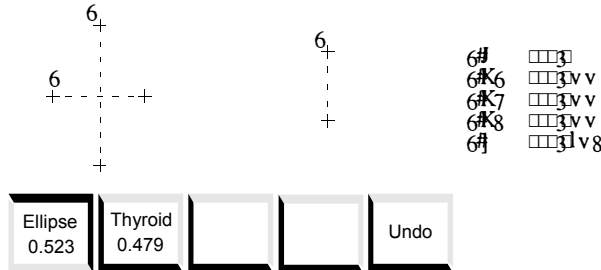

The coefficient used for the volume computation is also displayed in the measurement result

Measurement results		
C	xxx . x	C : Coefficient
D1	xxx . x mm	D1: Distance
D2	xxx . x mm	D2: Distance
D3	xxx . x mm	D3: Distance
V	xxx . x cm ³	V : Volume

pad.

When the “Volume” key is pressed, the following sub-menu is displayed:



A maximum of four volume measurements are available. The labels displayed in the measurement key give information about:

- the kind of volume the measurement apply to,
- the coefficient used in the computation. The volumes are computed according to the following formula:

$$V = D \alpha \cdot (D1 \cdot D2 \cdot D3)$$

- α : coefficient
- D1 : Distance 1 in millimetres
- D2 : Distance 2 in millimetres
- D3 : Distance 3 in millimetres
- V : Volume in cm³

The labels and coefficients are defined by the user in the Radiology Study Sheet (see *Chapter H, Radiology Study* on page 7-85). If the relevant data are not defined in the Radiology Study Sheet, the default measurements are the following:

- ellipsoid volume using a coefficient of 0.523:

$$V = D \frac{4/3 \cdot \pi}{8} \cdot (D1 \cdot D2 \cdot D3)$$

- α : coefficient = 0.523
- D1 : Distance 1 in millimetres
- D2 : Distance 2 in millimetres

D3 : Distance 3 in millimetres
 V : Volume in cm³

- thyroid volume using a coefficient of 0.479:

$$V = 0,479 \cdot (D1 \cdot D2 \cdot D3)$$

α : coefficient = 0.479
 D1 : Distance 1 in millimetres
 D2 : Distance 2 in millimetres
 D3 : Distance 3 in millimetres
 V : Volume in cm³

3.14.3.6 Ratio

The ratio computation is a *special* measurement related to the last measurement: e.g. if the user has made a distance measurement, by using the Ratio key, the user will make a second distance measurement and the ratio between the first distance measurement and the second one will be automatically computed.

The 2D ratio calculation is available for the:

- Distance measurement
- Area measurement

Ratio on 2D distance measurement

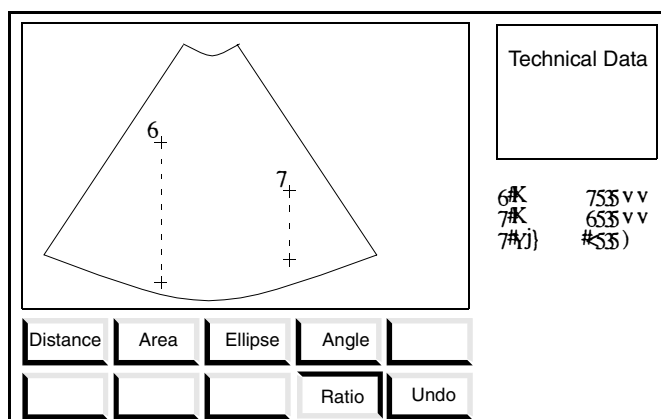

For the ratio on a 2D distance measurement, the result of the distance measurement and of the distance ratio measurement is displayed.

Ratio on 2D area measurement

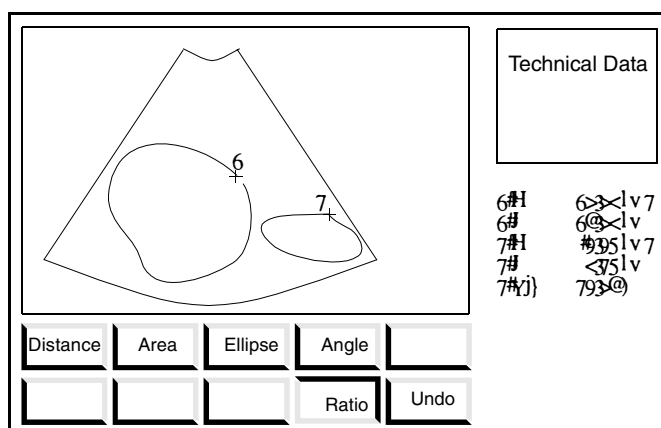

For the ratio on a 2D area measurement, the values of the area result and of the area ratio measurement is displayed.

3.14.3.7 Specific 2D Ob/Gyn Measurement

The specific Ob/Gyn (CRL, GES, ...) measurement can be classified in two groups:

- the specific measurements which use the distance measurement (CRL, FML, ...)
- the specific measurements which use area or ellipse measurement (AC, HC).

All these specific measurements work like a distance or an area/ellipse measurement. So the distance (or area/ellipse) results and the EFA (Estimated Foetal Age) results computed from the current measurement are displayed.

1	BPD	2.00	mm	Distance measurement
1	EFA	3+2	wk	
2	A	17.7	cm ²	Area/Ellipse measurement
2	AC	19.7	cm	
2	EFA	6+3	wk	

Remarks:

- the EFA is computed according to the current Ob/Gyn tables (selection made through the Ob/Gyn report).
- the report is automatically updated, according to the current measurement.
- If the user changes its working Ob/Gyn tables, the measurement pad will be automatically erased, to keep coherence between displayed data and Ob/Gyn setup. (report automatically updated).
- For more information refer to Appendix F, "Ob/Gyn Studies", on page 7-37.

2D Ob/Gyn measurement menu (NWA <= 15 weeks)

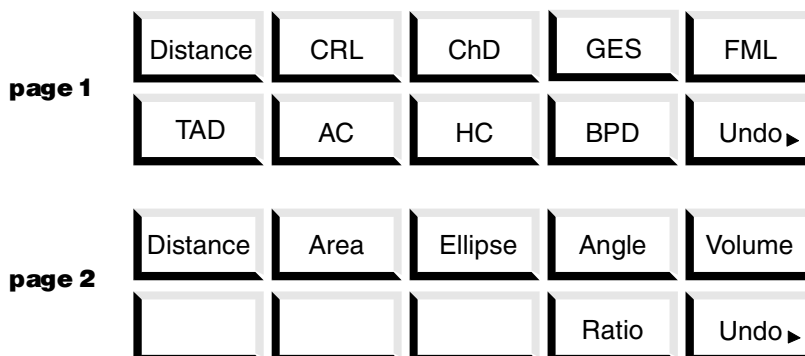

2D Ob/Gyn generic measurement menu (NWA > 15 weeks or unknown LMP)

page 1	Distance	BPD	HC	AC	TAD
	APD	FML	THD	HuL	Undo ▶
page 2	Distance	Area	Ellipse	Angle	Volume
				Ratio	Undo ▶

3.14.4 CFM Measurement

This is only available if CFM mode is installed on the SIGMA system. Refer to table 1-3, “System configuration and options,” on page 1-6 for SIGMA systems with CFM.

CFM measurement menuA

Distance	Area	Ellipse	Angle	
Velocity	Freq.	Vel. Prof	Ratio	Undo

The CFM measurement menu contains all the 2D measurements and some specific CFM measurements:

- CFM velocity mode:
 - the **velocity** and the **frequency** measurement: both are measured at the calliper position
 - the **velocity profile** measurement: the velocity is measured and displayed along a line.
- CFM power mode:
 - velocity and frequency measurement: not available.
 - **power profile** measurement: the power is measured and displayed along a line.

The blood flow measurement is available only in [CFM]/SP mode.

When entering in the CFM measurement menu, the distance measurement is set by default.

3.14.4.1 Distance

See 2D Measurement, Chapter 3.14.3.1, “Measuring a Distance”, on page 3-69

3.14.4.2 Area

See 2D Measurement, Chapter 3.14.3.2, “Measuring an Area”, on page 3-70

3.14.4.3 Ellipse

See 2D Measurement, Chapter 3.14.3.3, “Measuring an Ellipse”, on page 3-70

3.14.4.4 Angle

See 2D Measurement, Chapter 3.14.3.4, “Measuring an Angle”, on page 3-71

3.14.4.5 Velocity

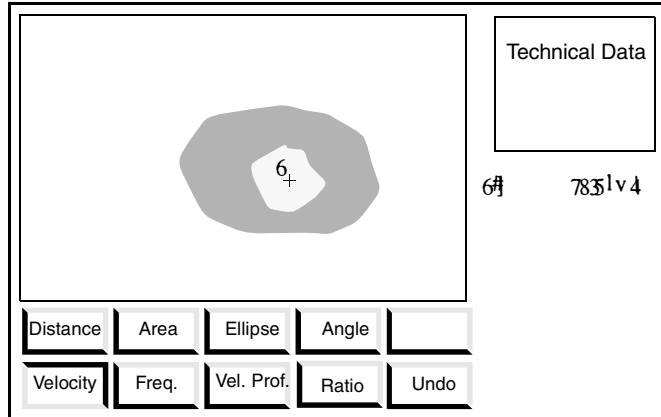

The CFM velocity measurement is made by setting one point on the image. The CFM velocity at this point is computed according to the current image format (velocity range), and is displayed in cm/s or m/s on the right side of the screen.

3.14.4.6 Frequency

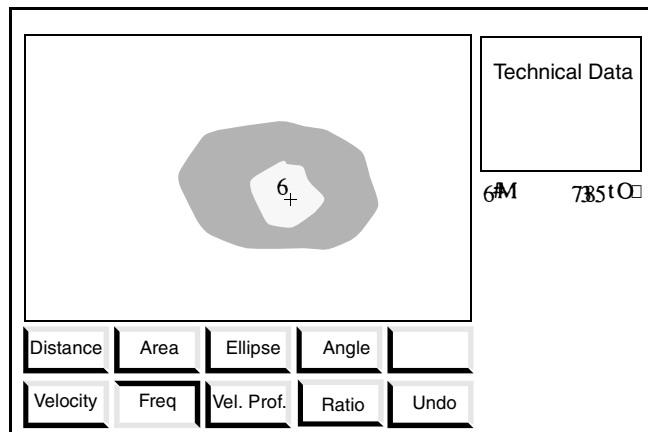

The CFM frequency measurement is made by setting one point on the image. The CFM frequency at this point is computed according to the current image format (velocity range), and is displayed in kilo Hertz on the right side of the screen.

3.14.4.7 Velocity/Power Profile

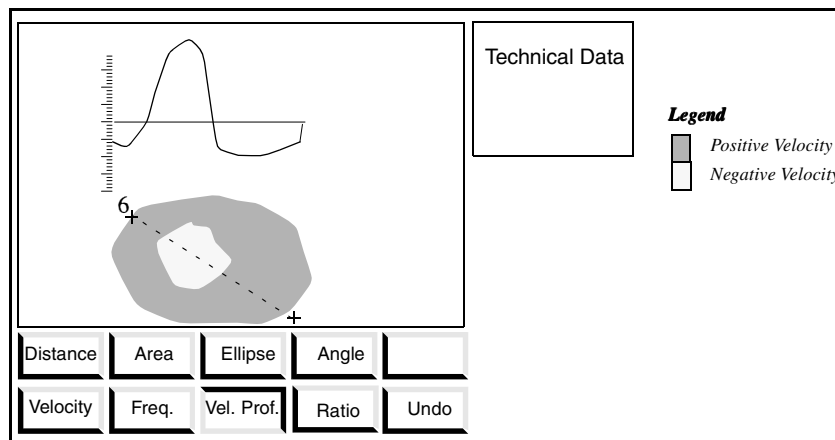

The CFM Velocity Profile measurement is made by setting two points on the image. When the second point is set, a graphical display of the CFM velocity or power from each point of this line will be made. No results are displayed on the right side of the screen.

3.14.4.8 Ratio

See 2D Measurement, Chapter 3.14.3.6, “Ratio”, on page 3-73

3.14.5 TM Measurement

If you press on **MEASURE** key in TM-mode, SIGMA 110/330 displays the following menu:

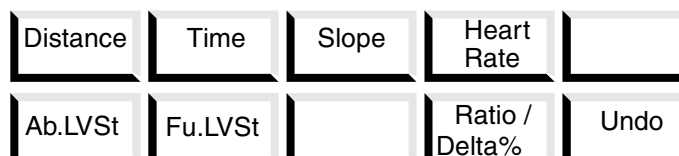

- **Distance:** default selection
- **Time**
- **SLOPE**
- **HeartRate:** Heart Rate
- **Ab_LVSt:** Abbreviated Left Ventricle Study
- **Fu_LVSt:** Full Left Ventricle Study
- **Ratio/Delta%:** Delta = $1-d1/d2$ for distance; Ratio = A/B for other meas.
- **Undo**

3.14.5.1 Distance

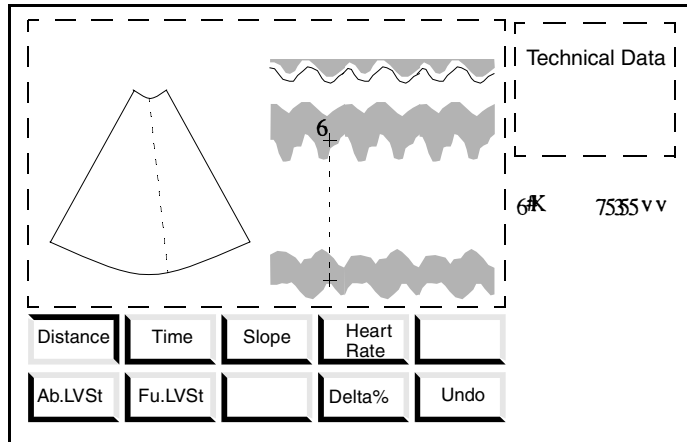

The TM distance measurement is made by setting two points on the image. The two cursors used for this measurement can only be moved in the vertical way. The distance between these points is computed according to the current image format (depth), and is displayed in millimetres on the right side of the screen.

3.14.5.2 Time

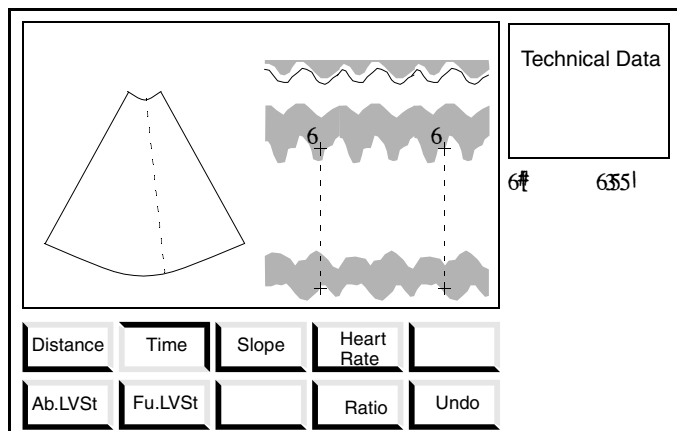

The TM Time measurement is made by setting two lines on the image (start and end line). The time between these two lines is computed according to the current scrolling speed, and is displayed in **seconds** on the right side of the screen.

3.14.5.3 Slope

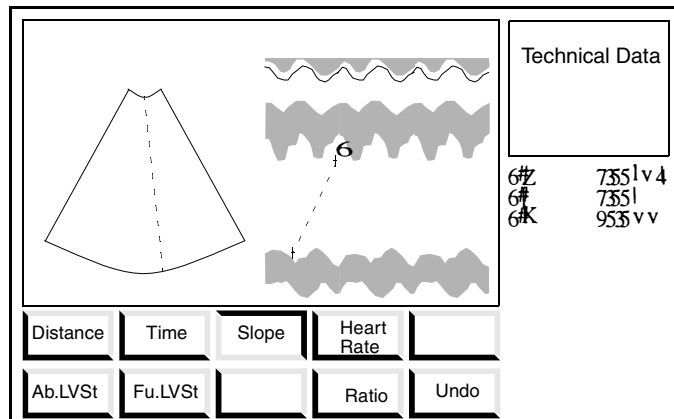

The TM Slope measurement is made by setting two points on the image. The slope between these two points is computed according to the current image format (depth for the distance and scrolling speed for the time), and is displayed in cm/s on the right side of the screen.

3.14.5.4 Heart Rate

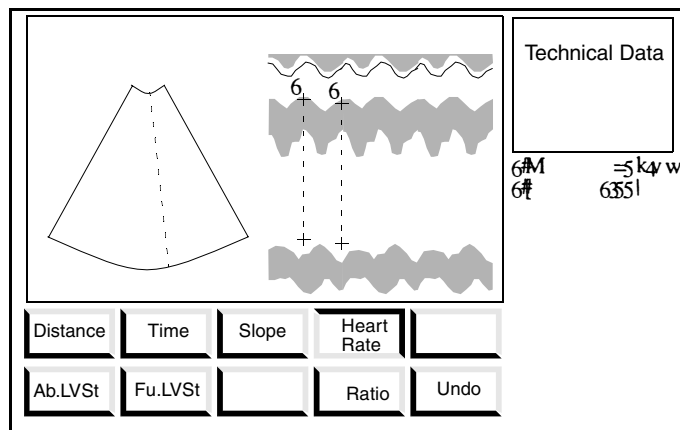

The TM Heart Rate measurement is made by setting two lines on the image (start and end line). The heart rate and the time between these two lines is computed according to the current scrolling speed, and is displayed in seconds for the time and in beats per minute for the heart rate on the right side of the screen.

3.14.5.5 Left Ventricular Study

The Left Ventricle Study can be computed as a full measurement or as an abbreviated measurement.

So two different entries are implemented in the TM measurement menu:

- Fu.LVSt: Full Left Ventricle Study:

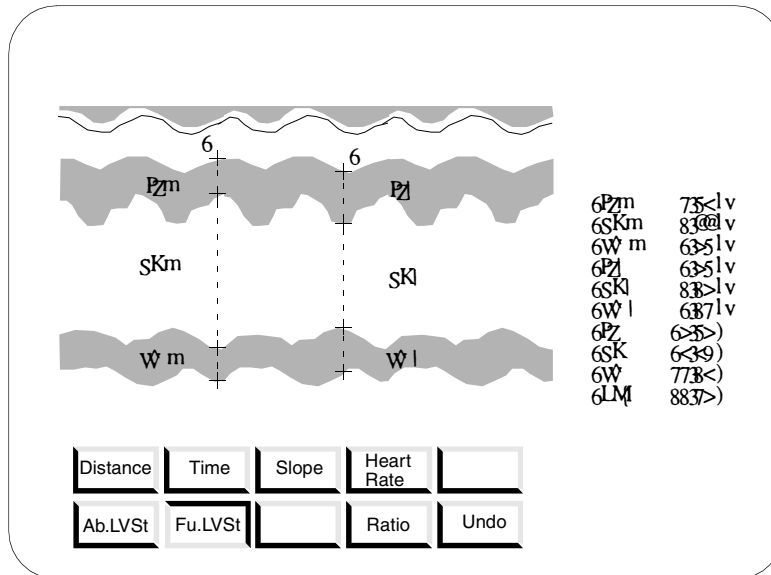

- ISd: Inter Ventricular Septal Thickness (diastole) in cm
- LDd: Left Ventricle Diameter (diastole) in cm
- PWd: Posterior Left Ventricular Wall (diastole) in cm
- ISs: Inter Ventricular Septal Thickness (systole) in cm
- LDs: Left Ventricle Diameter (systole) in cm
- PWs: Posterior Left Ventricular Wall (systole) in cm
- IS: Inter Ventricular Septal Thickness ratio
- LD: Left Ventricle Diameter ratio
- PW: Posterior Left Ventricular Wall ratio
- EFr: Ejection Fraction

□ Ab.LVSt: Abbreviate Left Ventricle Study

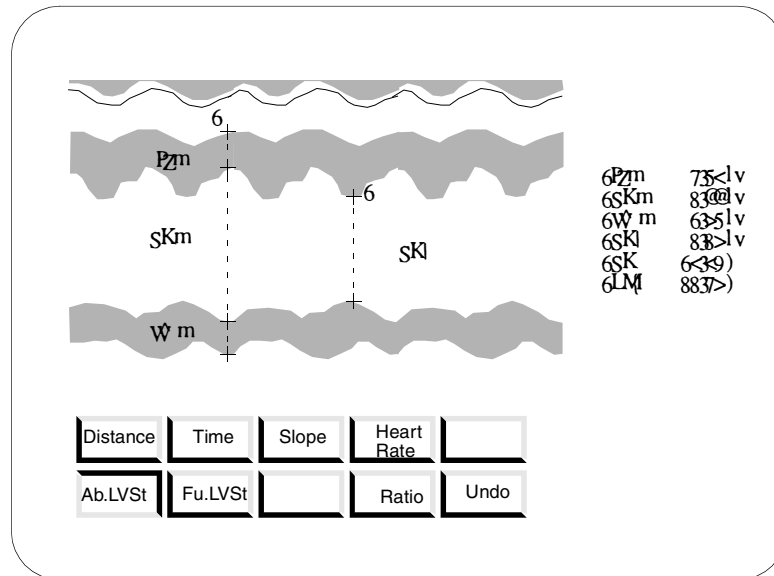

3.14.5.6 TM Ratio or Delta Ratio

The TM ratio (or delta ratio) calculation is available for the:

- TM Distance measurement (delta ratio)
- TM Time measurement (ratio)

Delta ratio on TM distance measurement

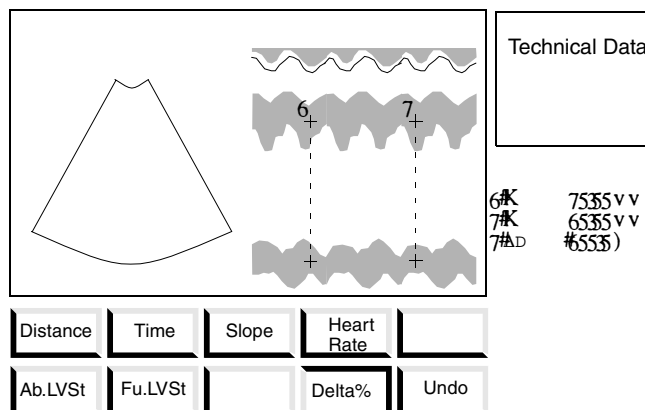

For the delta ratio on a TM distance measurement, the result of the distance measurement and of the distance delta ratio measurement is displayed.

Ratio on TM time measurement

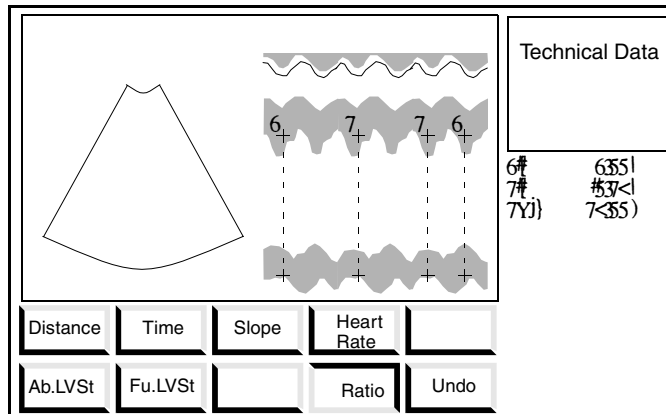

For the ratio on a TM time measurement, the result of the time measurement in seconds and of the time ratio measurement in percent is displayed.

3.14.6 Doppler Measurement

If you press on **MEASURE** key in SP-mode, SIGMA 110/330 displays the following menu, depending on Medical Application:

- Cardio application:

page 1

SpeedGr.	Freq.	VTI	Time	HeartRt
PI&RI	Mitral	PHT	Ratio	Undo ▶

page 2

Acceler.		MVI		
BloodFl.	RI			Undo ▶

- Ob/Gyn application:

page 1

SpeedGr.	Freq.	VTI	Time	HeartRt
PI&RI	RI	PHT	Ratio	Undo ▶

page 2

Acceler.		MVI		
BloodFl.	Mitral			Undo ▶

- other applications:

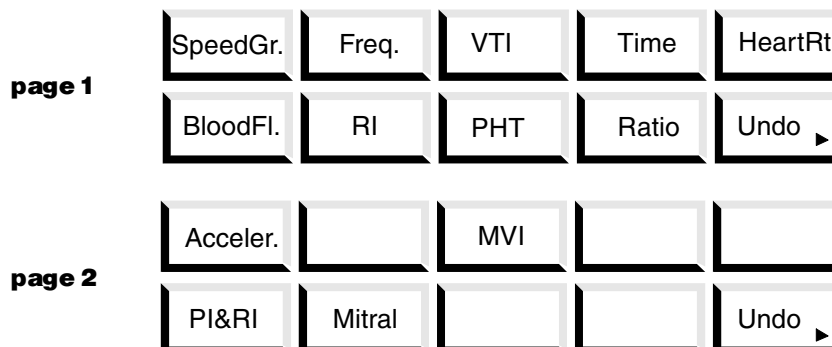

Note that the Doppler vector angle must be carefully adjusted before the blood flow measurement is started. A message is displayed just above the menu, when the measurement is entered:

"Please check the position of the Doppler vector angle before the measure starts"

3.14.6.1 Speed/Gradient Measurement

For the Speed/Gradient measurement (and the frequency measurement), the start point is linked to the baseline and it can only be moved horizontally. When the user turns the trackball in the vertical direction, he moves the second point, which gives the velocity (this point can be moved in the positive and the negative areas).

1. Press **F1 (SpeedGr.)** to select speed gradient measurement.
2. Use the trackball to move the marker to the desired position.
3. Press **upper left SET** key to fix the marker. The result is automatically displayed on the screen. The dotted line stays if the preference "dotted line" has been selected in the set up preference menu. The dotted line disappears if the preference "no dotted line" has been selected in the set up preference menu.

During the measurement, the user can delete a part of the current measurement by pressing on the **BACKSPACE** (⇐) key.

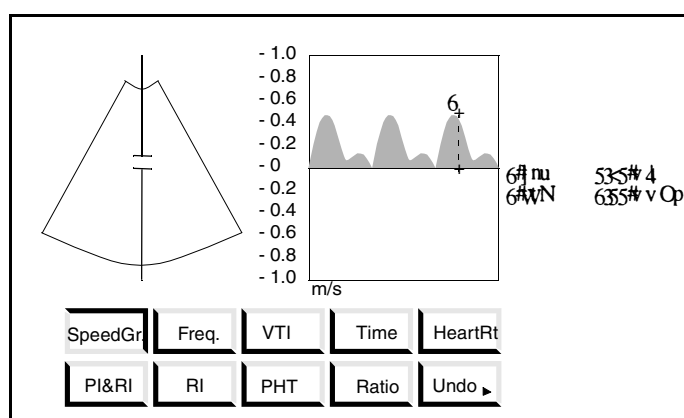

The result of the Speed/Gradient measurement depends on the current SP scale and is displayed in centimetres per seconds (if the maximal scale velocity is in centimetres per seconds) or in meters per second on the right side of the screen.

3.14.6.2 Frequency Measurement

The frequency measurement is made like the Speed/Gradient measurement, but the result is displayed in kHz.

1. Press **F2 (Freq.)** to select frequency measurement.
2. Use the trackball to move the marker to the desired position.
3. Press **upper left SET** key to fix the marker. The result is automatically displayed on the screen. The dotted line stays if the preference "dotted line" has been selected in the set up preference menu. The dotted line disappears if the preference "no dotted line" has been selected in the set up preference menu.

During the measurement, the user can delete a part of the current measurement by pressing on the **BACKSPACE** (\leftarrow) key.

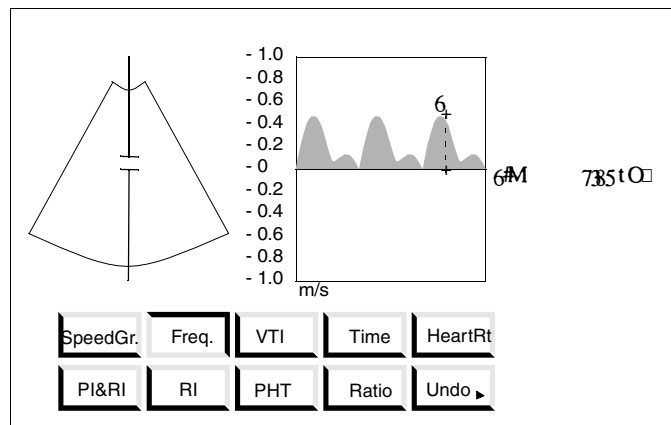

The result of the frequency measurement depends on the current SP scale and is displayed in kHz on the right side of the screen.

3.14.6.3 Velocity Time Integral and Mean Velocity Integral Measurement.

By adding VMean/VMax automatic detection feature, the integral measurement has been modified to be made automatically or manually on the two different integrals types:

- VMax integral
- VMean integral

On the ultrasound page these two integral measurement results are always called I for Integral, but on the biometry pages, these two results are called differently to be easily distinguished.

If VTI or MVI measurement is selected by the user, a sub-menu is displayed to erase the last displayed points (equivalent to the Backspace key) or to be able to switch from automatic to manual integral computation (for VTI only, MVI is always automatic).

Automatic VMax and VMean measurement

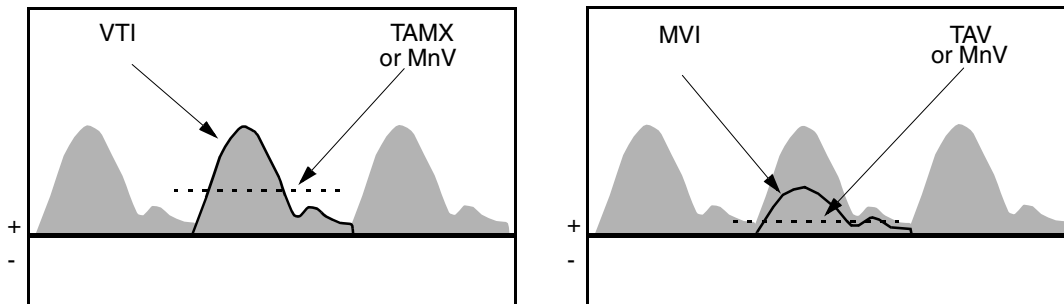

Biometry results for VMax

VTI	xx.xx	cm
PkV	xx.xx	cm/s
TAM	xx.xx	cm/s
PkG	xx.xx	mmHg
MnG	xx.xx	mmHg

Biometry results for VMean

MVI	xx.xx	cm
PkV	xx.xx	cm/s
TAV	xx.xx	cm/s
PkG	xx.xx	mmHg
MnG	xx.xx	mmHg

1. When the first integral point is set, the integral (VMax or VMean) will be drawn automatically by moving the trackball to the right (follows the blue points in a VMean integral measurement and the orange points in a VMax integral measurement).
2. To finish the integral measurement, the user will press on the **Upper Left Set Key**.
3. By pressing on the VTI/MVI key, the following menu will be displayed (when MVI is pressed, the Auto/Manual button is disabled).



For VTI, the drawing mode defined in the preference menu is activated (default VMax auto.). So in the preference menu, an entry permits to choose between the automatic or manual VTI computation.

4. If the user agrees the default drawing mode, he starts his measurement by setting the first integral point at the desired position by pressing the **Upper Left Set Key**. If he wants to use another drawing mode, he just presses on the **Manual/Auto** key.

Remarks:

- During automatic VTI computation, the user can switch to the manual mode by pressing on the **Manual/Auto** key and return to the previous automatic mode by pressing on the same key (auto/manual toggle key on **F1**).
- During automatic VTI/MVI computation, the user can erase a part of the current measurement, by pressing on the **Backspace** key on the right of the alphanumeric keyboard or on the **F4** key (same function as backspace) or on the **F5** key (equivalent to 5 backspace) or move the trackball from the right to the left.
- Manual integral measurement (VTI only):
By choosing this mode (available only for VTI), the user can draw the integral himself.

3.14.6.4 Time

See TM Measurement, Chapter 3.14.5.2, “Time”, on page 3-78 for details.

3.14.6.5 Heart Rate

See TM Measurement, Chapter 3.14.5.4, “Heart Rate”, on page 3-79 for details.

3.14.6.6 Blood Flow

This measurement is only available in 2D/SP, 2Di/SP, CFM/SP or CFMi/SP modes.

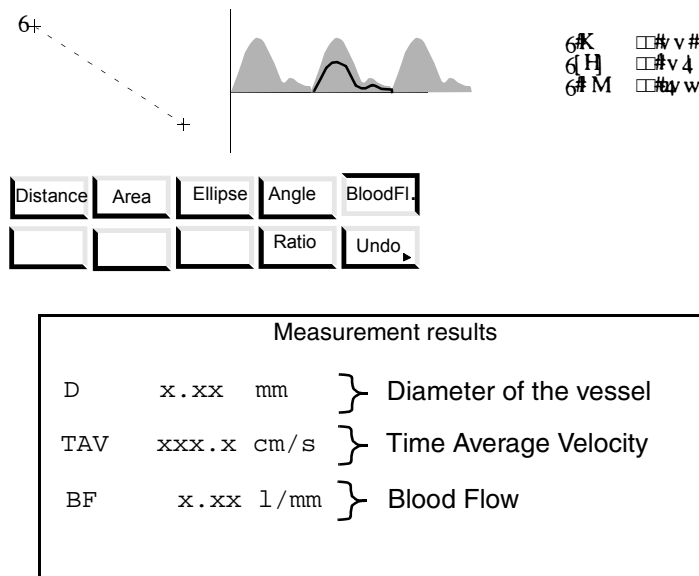

The blood flow is measured in two steps and a message displayed for each step just above the menu:

- first doing a distance measurement on the 2D image.
The message “*Distance measurement*” is displayed.
- then doing a MVI measurement on the SP pad to get the TAV
The message “<SET>: *select the first point of the MVI integral*” is displayed. Once, the first point is selected, the MVI sub-menu is displayed (see *Chapter 3.14.6.3, Velocity Time Integral and Mean Velocity Integral Measurement*, on page 3-84).
The blood flow is computed by using the formula:

$$BF = \frac{TAV \cdot 60 \cdot \frac{\pi}{4} \cdot D^2}{1000}$$

BF : Blood Flow in l/min.
TAV : Time Average Velocity in cm/s
D : Diameter of the vessel in cm

Note that the calliper moves are automatically limited to the right pad (2D pad for distance measurement and PW pad for MVI measurement).

3.14.6.7 Pulsatility and Resistance Index Measurement

Like for the VTI/MVI measurement, the PI/RI measurement can be made in automatic or manual mode, the same menu than the integral menu is displayed when pressing on the PI & RI key. This measurement is similar to the VMax Integral (Chapter 3.14.6.3, “Velocity Time Integral and Mean Velocity Integral Measurement.”, on page 3-84).

The PI and RI measurements are computed by drawing an integral on the Doppler spectrum and by setting the Diastole point (the Systole point is automatically computed and is equal to the Peak Velocity). All these results are displayed on the right side of the screen.

3.14.6.8 Resistance Index Measurement

The RI measurement is computed by setting two velocities on the Doppler spectrum and the result is displayed on the right side of the screen.

1. Press **F7 (RI)** to select resistance index measurement.
2. Use the trackball to move the first velocity marker to the desired position.
3. Press **upper left SET** key to fix the marker; the first velocity is set, the second velocity marker is now available.
4. Use the trackball to move the second marker to the desired position.
5. Press **upper left SET** key to fix the second velocity marker. The result is automatically displayed on the screen.

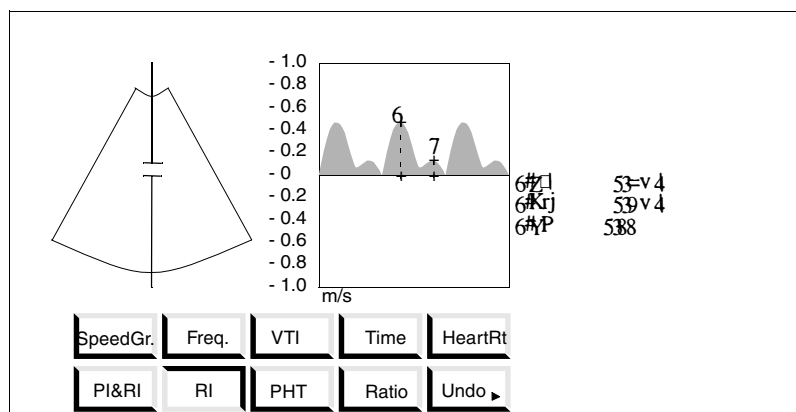

The Systolic velocity is displayed in cm/s or m/s.

The Diastolic velocity is displayed in cm/s or m/s.

3.14.6.9 Pressure Half Time Measurement

The Pressure Half Time is measured by setting two points (like for the acceleration measurement) on the Doppler spectrum.

1. Press **F8 (PHT)** to select pressure half time measurement.
2. Use the trackball to move the first marker to the desired position.

3. Press **upper left SET** key to fix the marker; the second end marker is now available.
4. Use the trackball to move the second marker to the desired position.
5. Press **upper left SET** key to fix the second marker. The result is automatically displayed on the screen.

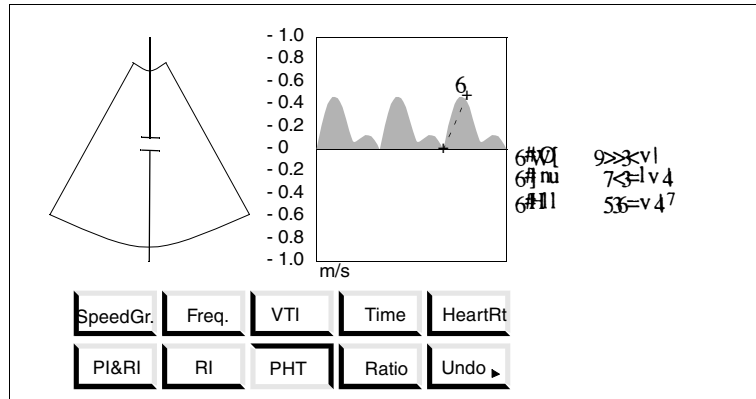

Pressure Half Time is displayed in ms.
 Peak Velocity is displayed in m/s.
 Acceleration is displayed in m/s^2 .

3.14.6.10 Ratio Measurement

- On Speed measurement and on frequency measurement:

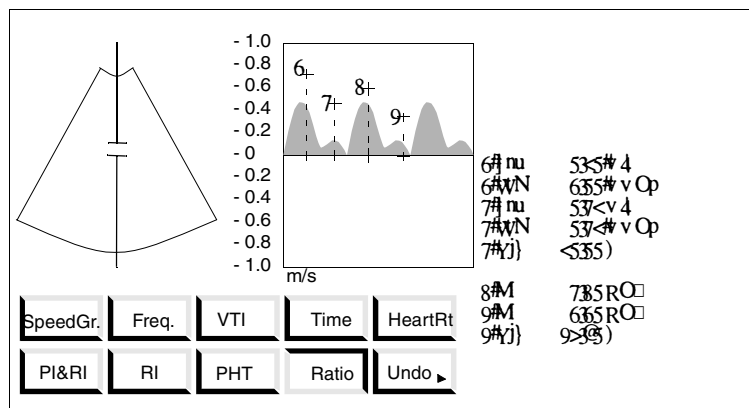

For the ratio on a Speed (or Frequency) measurement, the result of the speed (or frequency) and of their ratio is displayed.

- On Doppler Time measurement:
 Refer to Chapter 3.14.5.6, “TM Ratio or Delta Ratio”, on page 3-81

3.14.6.11 Acceleration Measurement

The Acceleration is measured by setting two points on the Doppler spectrum. The acceleration between these points is computed according to the current image format (velocity and scrolling speed), and is displayed in **meter per square second** on the right side of the screen.

1. Press **F1** on menu page 2 (**Acceler.**) to select acceleration measurement.
2. Use the trackball to move the first marker to the desired position.
3. Press **upper left SET** key to fix the marker; the second end marker is now available.
4. Use the trackball to move the second marker to the desired position.
5. Press **upper left SET** key to fix the second marker. The result is automatically displayed on the screen.

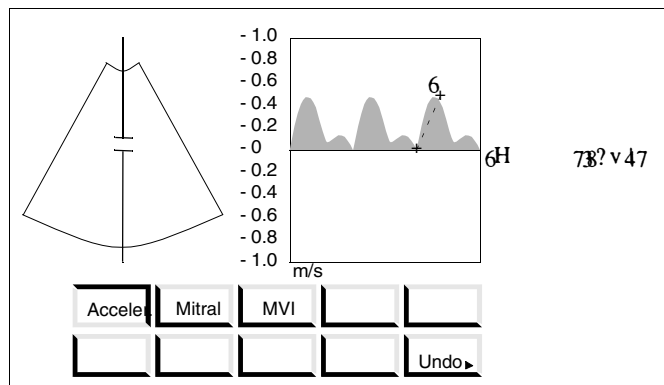

Acceleration is displayed in m/s^2 .

3.14.6.12 Mitral Valve Measurement

The Mitral Valve Area is measured by setting two points (like for the acceleration measurement) on the Doppler spectrum.

1. Press **F2** on menu page 2 (**Mitral**) to select mitral measurement.
2. Use the trackball to move the first marker to the desired position.
3. Press **upper left SET** key to fix the marker; the second end marker is now available.
4. Use the trackball to move the second marker to the desired position.
5. Press **upper left SET** key to fix the second marker. The result is automatically displayed on the screen.

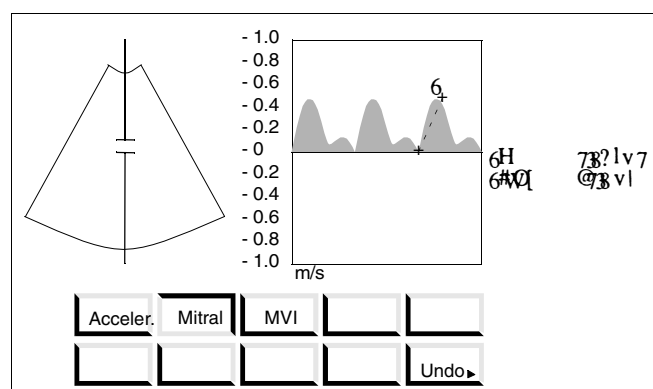

Mitral Valve Area is displayed in cm^2 .

Pressure Half Time is displayed in ms.

3.15 Biometry and Report

See also Chapter 7, "APPENDICES", on page 7-1

3.15.1 Biometry Pictograms

The pictograms which appear on all biometry/report sheets are described in Appendix 7, "APPENDICES", on page 7-1

3.15.2 Patient Information

The patient identification screen contains the information concerning patient and laboratory. (See Appendix C, "Patient Information", on page 7-7)

For each new patient, the user must invoke this mode to clear all biometry measurement and results.

Some data which appears on this screen can be modified in the report; data modified in the report are automatically changed on this page.

The best way to start a new patient study is:

1. Press **ID** key to display the Patient information sheet.
2. Select **New Patient** to erase all patient information.
3. Enter information concerning the new patient with the alphanumeric keyboard.
To enter text:
 - Move the cursor on the area to be filled in with the trackball; the selected zone is highlighted.
 - Enter the characters.
 - End with ↵ (**ENTER** key).

3.15.3 Biometry Patient Study

The Biometry patient study is made of measurements and calculations according to medical applications.

The different biometry pages have the following arrangement:

- At the top of the page, the patient and laboratory information is displayed, and can be modified directly. The patient identification page will be automatically updated according to this modification. When some modifications are made from the Patient Identification page, the information displayed on the biometry page is updated.
- The second part of this page contains the different biometry calculation (medical application dependent).
- The third part contains the different tools icons. Remark: an inverted video icon means that it is selected.

The cursor can be moved with the trackball. When the cursor is over a valid measurement field, the selected field is displayed in inverted video. To select the current measurement, the user press on the **SET** key or **ENTER** key.

By selecting the **REPORT** icon, the user displays the printable report of his measurement.

The **TRASH** icon is used to delete a result.

To delete a result:

1. Select the field to be cleared (a selected field is displayed in inverted video).
2. Select the **TRASH** icon, the selected field will be reset to zero.

By pressing **F1 (MEDICAL APPLICATION)**, the user can change the medical application.

The **CURVE VIEW** icon is used to display the different curves:

- from OB/GYN STUDY sheet: place the cursor on the measurement of interest; when the field is highlighted press **F3 (CURVE VIEW)**; the corresponding curve is displayed.
- from OB/GYN SETUP sheet: place the cursor on the name of the desired gestational table and press **F3 (CURVE VIEW)**; the corresponding curve is displayed.

The "Curve View" sheet displays the selected curve, the related measurement values and the Number of Weeks of Amenorrhea (NWA). Note that a point is displayed on the curve; this point is the measurement of interest when NWA is less than 15 weeks; else, the displayed point matches with NWA.

See the different Biometry sheets in Chapter 7, "APPENDICES", on page 7-1.

3.15.4 Report

This function produces a document with all the measurement values, calculation results and patient data, reasonably arranged in patient report. All information is shown in an explicit form.

The report can be displayed on the screen by pressing REPORT icon in the Biometry Study Menu.

The report can be printed on parallel printer by pressing PRINT icon in the Biometry Study Menu.

3.15.5 Starting a Study

To start a study on a new patient, the following operations are required:

1. Editing a patient identification sheet
2. Editing a biometry study sheet

3.15.5.1 Editing a Patient Identification Sheet

To edit a patient identification sheet:

1. Press **ID** key.
The complete patient identification data sheet appears on the screen.

Note

The New Patient icon deletes all data, except those related to Laboratory identification. This function is recommended to restart a study at the beginning or to start a study on a new patient.

2. Type on alphanumeric keyboard to fill out the desired areas. Please refer to Chapter 3.12.3, "Manual Text Annotation", on page 3-60.
3. Press REPORT key to display the biometry study sheet which corresponds to current mode and medical application

- or press ID key to return to a frozen image.
- or press FREEZE key to return to a live image.

3.15.5.2 Editing a Biometry Study Sheet

To edit a biometry sheet:

1. Acquiring the required ultrasound image
2. Press **REPORT** key. The specific biometry study sheet appears on the screen.
3. Click¹ on the desired area corresponding to measurement to be performed.
 - The ultrasound image appears on the screen
 - Perform the required measurement. See Chapter 3.14, "Measurements", on page 3-67.
 - After completing the measurement the screen automatically toggles to the biometry sheet.
 - The value of the measurement is stored in the current field.
4. Repeat the operations in item 3 as many time as required.
5. Select **REPORT** pictogram to edit the corresponding report or select NEXT PAGE pictogram to display the next page of the Biometry study.

The user can exit the current Biometry Study using the following keys:

- ❑ **REPORT** to return to the frozen image
- ❑ **FREEZE** to return to the live image
- ❑ **MAGNIFY** to magnify the frozen image
- ❑ **MEASURE** to enter Measurement Menu (frozen image)
- ❑ **ANNOTATE** to enter Annotate Menu (frozen image)
- ❑ **ESC** to exit Biometry Study when first sheet is displayed (see also Chapter 1.4, "System Controls", on page 1-28).

Note

During some transfers, "Please wait..." message appears on the screen to show that the system is changing display format.

3.15.6 Radiology Study

The abdominal and pediatrics study is included on the radiology study sheet. See Radiology study sheet, measurements and equations in Appendix H, "Radiology Study", on page 7-85.

1. Click = TRACKBALL/CURSOR + SET, move the cursor to the desired area (when the cursor is over a selectable area, the corresponding field is highlighted) and press SET.

3.15.7 Obstetrics/Gynaecology Study

From Ob/Gyn Medical Application:

3.15.7.1 EBD according to LMP

1. Press **REPORT** key to display Ob/Gyn Study Sheet.
2. Highlight LMP area with trackball and enter the date of Last Menstrual Period with alphanumeric keyboard as:
 - Day/Month/Year for PAL version Example: 26/02/2001 (26 February 2001)
 - Month/Day/Year for NTSC version Example: 02/26/2001 (February 26th, 2001)

When LMP date information is entered, the system calculates EBD (Estimated Birth Date) and NWA (Number of Weeks of Amenorrhea).

3.15.7.2 Fetus Age according to Physical Measurement

1. Acquire an ultrasound image in 2D mode.
2. Press **REPORT** key to display Ob/Gyn Study Sheet.
3. Select (in the "Meas" column) the field corresponding to the parameter to be measured; when it is highlighted ...
4. Press **SET** key; the system switches to the ultrasound image display.
5. Perform the required measurement; the according value and estimated foetus age appear on screen; when the measurement is confirmed, the study sheet is displayed again. The measured value is stored and displayed in the study sheet.
6. For each measurement, the system determines the Age of the fetus and EBD, using a table. When all measurements are performed, the system calculates some parameters and ratios such as AUA..., HC/AC...

3.15.7.3 Growth Curves

The **CURVE VIEW** icon is used to display the different growth curves:

- from OB/GYN STUDY sheet: place the cursor on the measurement of interest; when the field is highlighted press **F3 (CURVE VIEW)**; the corresponding curve is displayed.
- from OB/GYN SETUP sheet: place the cursor on the name of desired gestational table and press **F3 (CURVE VIEW)**; the corresponding curve is displayed.

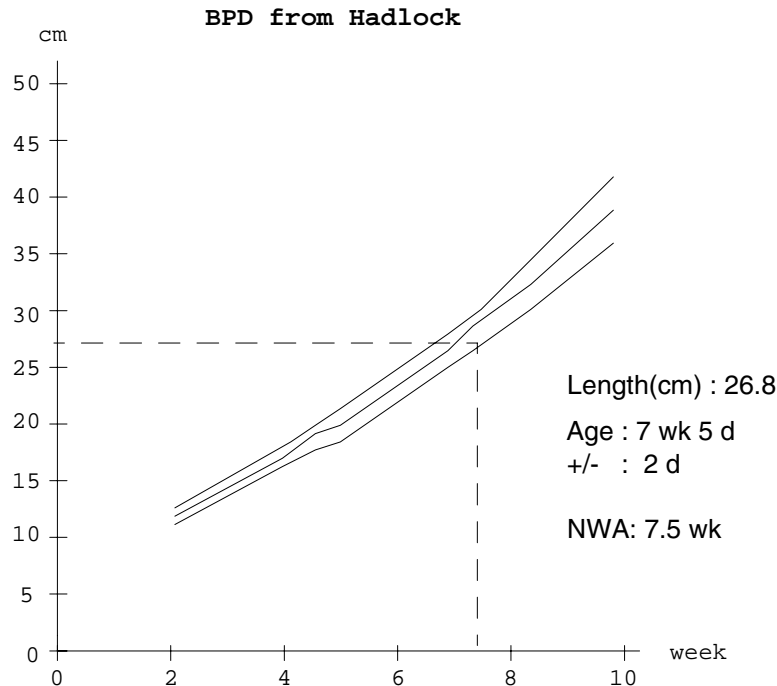

The point displayed is obtained with the NWA (according to the LMP), and the value measured. Its position, compared to the reference curve, gives an immediate indication of the fetus growth. See OB/GYN study sheet, SETUP sheet, USER SETUP table, measurements and equations in Appendix F, "Ob/Gyn Studies", on page 7-37.

3.15.8 Vascular Study

The Vascular study sheet is displayed in Vasc. Medical Application.

A vascular study sheet is available in Radio Medical application when PW or CW mode is selected.

See Vascular study sheet, measurements and equations in Appendix E, "Vascular Study", on page 7-31.

3.15.9 Cardiology Study

The Cardiology study includes four study sheets:

- Left Ventricle Study
- Mitral Valve Study
- Aortic Valve Study
- Right Ventricle Study

See Cardiology study sheets, measurements and equations in Appendix D, "Cardiology Study", on page 7-11.

3.16 ECG (Option)

The optional ECG Module can be coupled to SIGMA 110 and SIGMA 330 systems via COM1 input located on the rear connector panel.

The ECG Module includes an ECG signal amplifier for displaying the trace on the video screen and a QRS detector for synchronizing the 2D image.

ECG is activated for Cardio Setups (enabling is probe setup dependent). It is disabled by default for other applications.

To enable ECG:

1. Press SETUP key on the keyboard
2. Press Prefs in the Setup Menu
3. Press Display in the Preferences Menu
4. Press ECG ON in the Display Menu

Heart Rate (HR, in b/min.) is automatically calculated by the system (average on 5 QRS periods) when the QRS waveform appears on the screen, and displayed at the bottom right of the screen.

The ECG Module can provide four error messages: "NO ECG", "LEAD OFF", "ECG ERROR" and "BAD ELECTRODE". These messages are displayed in red, in the place of Heart Rate when they occur.

- | | |
|--|--|
| <input type="checkbox"/> NO ECG: | ECG not connected or connected wrongly |
| <input type="checkbox"/> LEAD OFF: | clamps are defective or not correctly placed on the patient |
| <input type="checkbox"/> BAD ELECTRODE: | clamps are defective or not connected |
| <input type="checkbox"/> ECG ERROR: | when a failure happens in the ECG software module. Freeze, then unfreeze the system to work out the problem. |

The Trigger mode allows the synchronization of 2D image. The softkey Trigger Off/1/1+2 is used to disable/enable one or two triggers.

The ECG On/Off preference can be selected for each probe and saved in each probe setup.

3.17 EasyPrint Options

These options are:

- EasyPrint™ B & W for SIGMA 110 systems; this option requires CINE Option.
- EasyPrint™ Color for SIGMA 330 systems.

The EasyPrint™ Options allow the user to print Patient Reports and ultrasound images. The images must be previously saved on a memory card before printing. The printing process is done while the system can continue to perform other tasks. This allows the user to work during the images are printed.

3.17.1 Printing of images

3.17.1.1 Selection of images for printing

- Store the images to be printed on a memory card (SRAM), see Chapter 3.11.1, “Image Storage and Freeze Menu”, on page 3-51.
- View the Panel of 16 images (thumbnails), see Chapter 3.11.2, “Archive: Display of Stored Images”, on page 3-52.

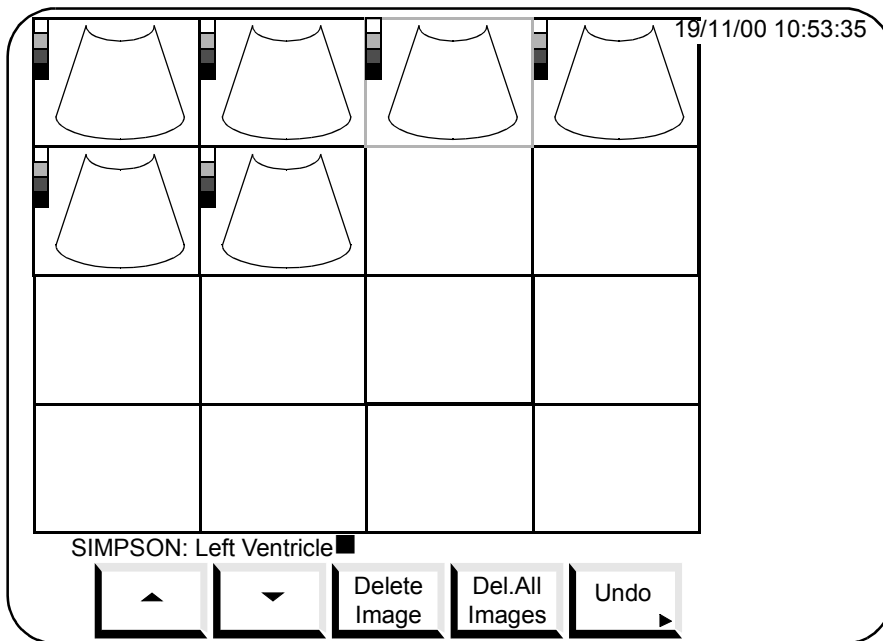

- Select each image to print with the trackball and by pressing the “SELECT” key; the number of selected images is displayed over the thumbnail; it defines also the position of the image on the printed page.
- You can also press directly on the PRINT2 key: all the images from the current patient will be selected and printed.

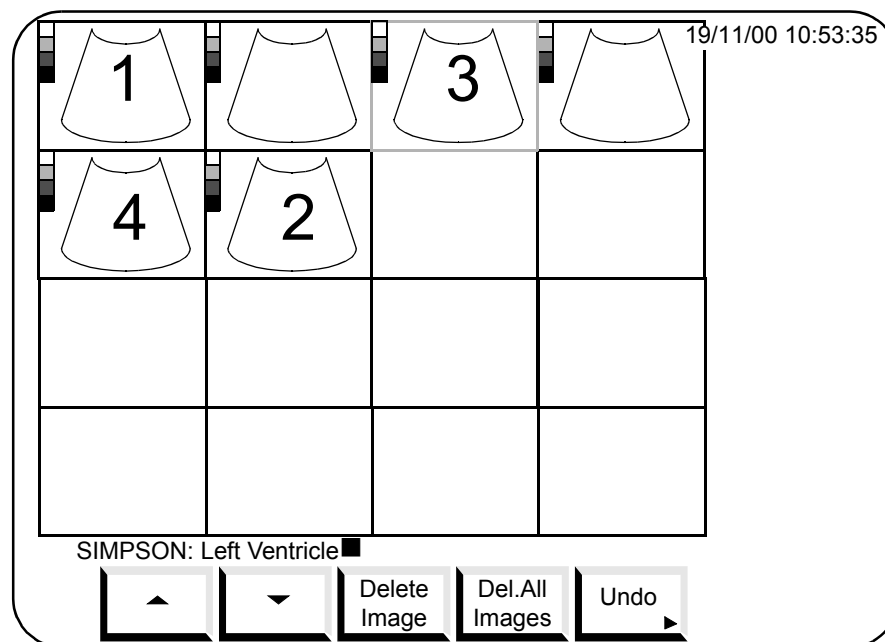

- An image can be removed from the list at any time: just press on the “SELECT” key again when it is highlighted (use the trackball). If the user unselects the image labelled “2”, the thumbnail page is updated as shown below:

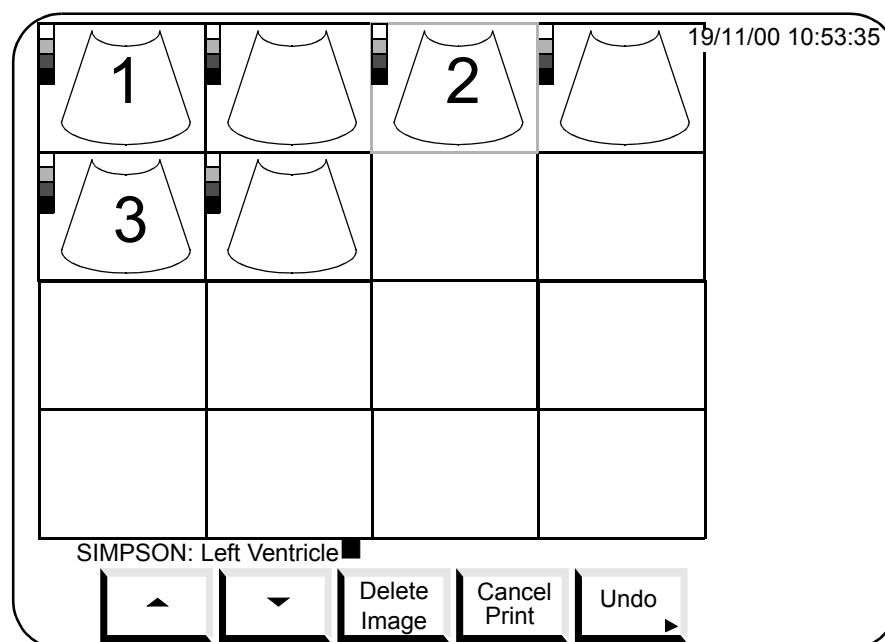

- To print the selected images, press on PRINT2.
Note that the image title is always printed when available.

Be careful, do not remove the memory card during this process; otherwise the print process will be cancelled.

3.17.1.2 Print Deletion

The “Delete All Images” menu item is changed into “Cancel Print” during the print process. When this key is selected, a confirmation dialogue box is displayed first. The print is cancelled if the user validates it.

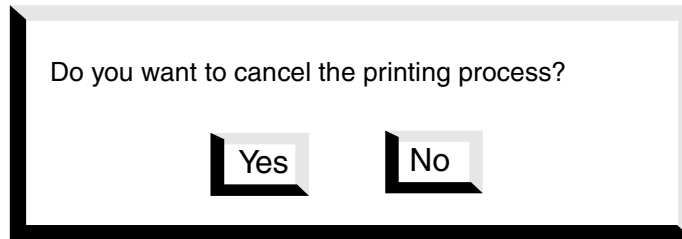

Moreover, if the flashcard is removed while the print is in progress, the print is automatically cancelled and an error message is displayed. See Chapter 5.5.17, “Error 16: Flashcard removed while printing”, on page 5-21.

3.17.2 Printing of Report

Printing of Patient Report is available from the Report menu.

3.18 USB-LinkTM Option

3.18.1 Overview

The USB-LinkTM option allows the connection of the ultrasound scanner to a computer, and so extends the KIPRISM capabilities. With USB-LinkTM, the SRAM memory card is recognized by the computer as if it was a removable hard-disk. All the images, report and patient information saved on it can be read from the computer.

Note that no more PCMCIA card reader is required to archive the SRAM memory card content on a personal computer.

3.18.2 Compatibility

The USB-LinkTM option is compliant with:

- MacOS 9 or upper,
- Microsoft[®] Windows[®] 2000 with Service Pack 3 installed

Please contact your local KONTRON MEDICAL representative for more information about system requirements.

3.18.3 Usage example with Windows^B 2000

3.18.3.1 Device identification

When the SIGMA and the computer are not connected together, typically you may have the following view from your file Explorer.

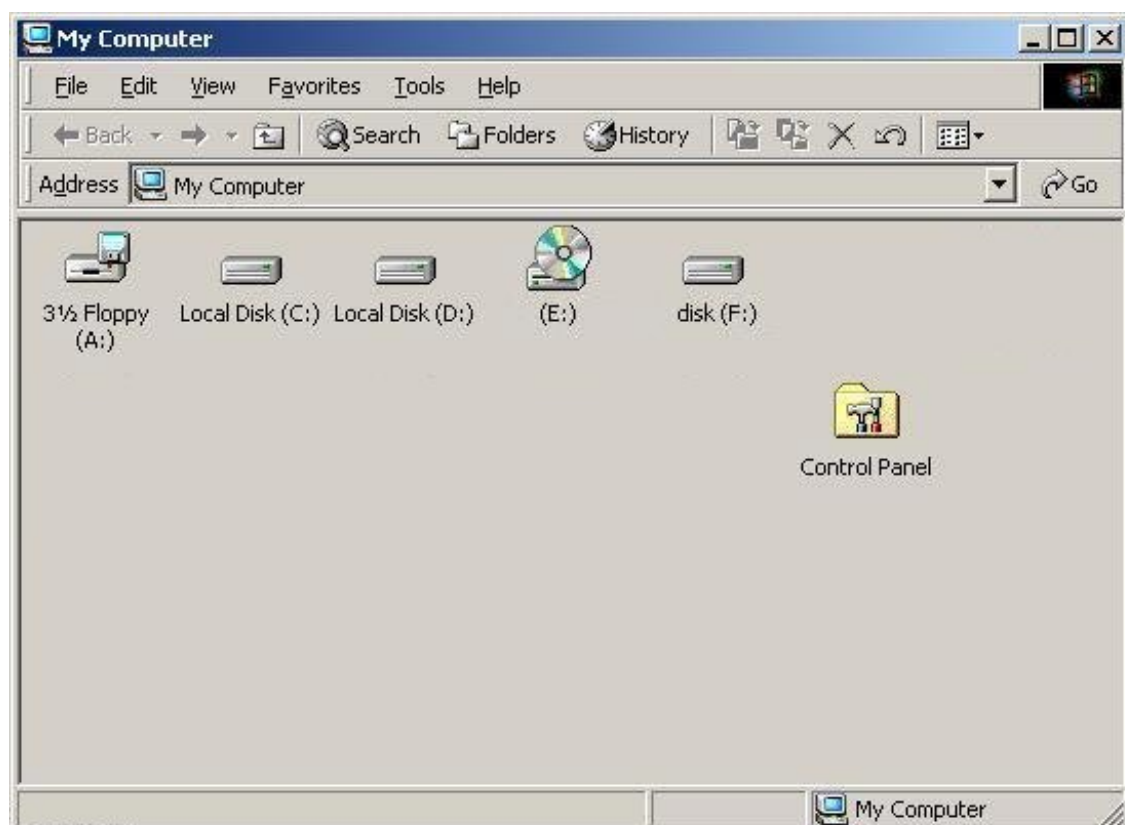

When the computer and the SIGMA are connected together, the SIGMA is recognized as a removable device.

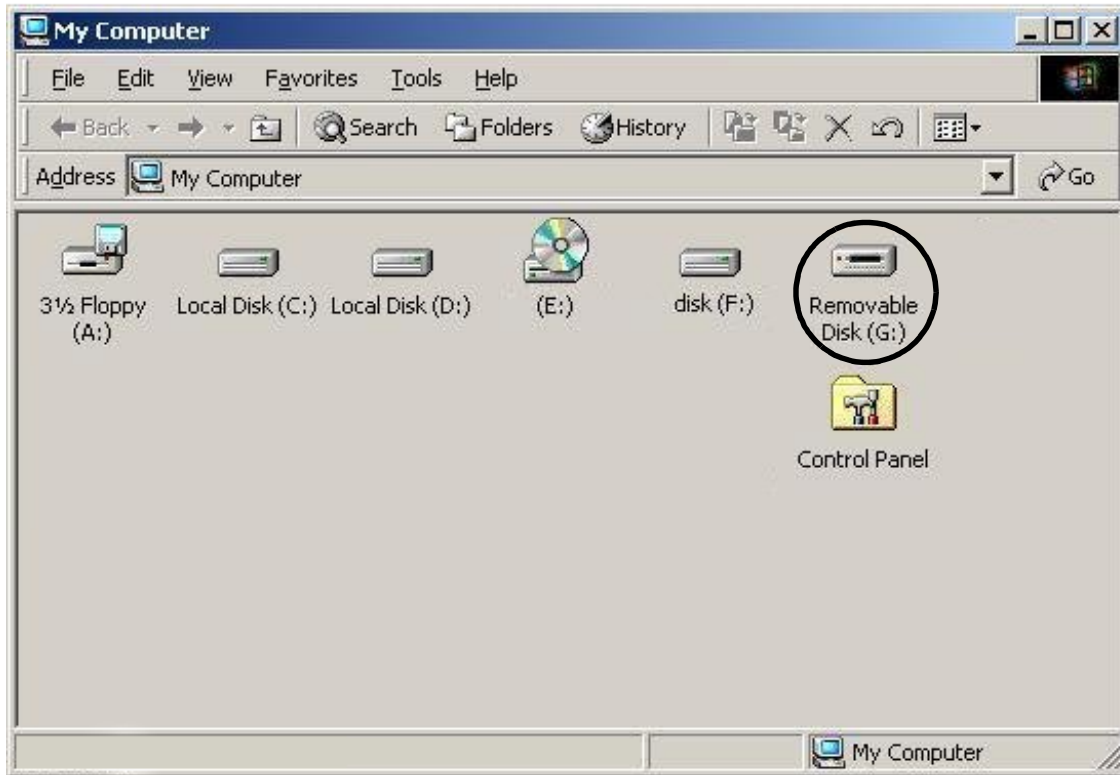

3.18.3.2 List flashcard content

If clicking on the removable disk device whereas no flashcard is plugged in the SIGMA, the following message is displayed:



When a flashcard is plugged, its content is displayed, as shown below:

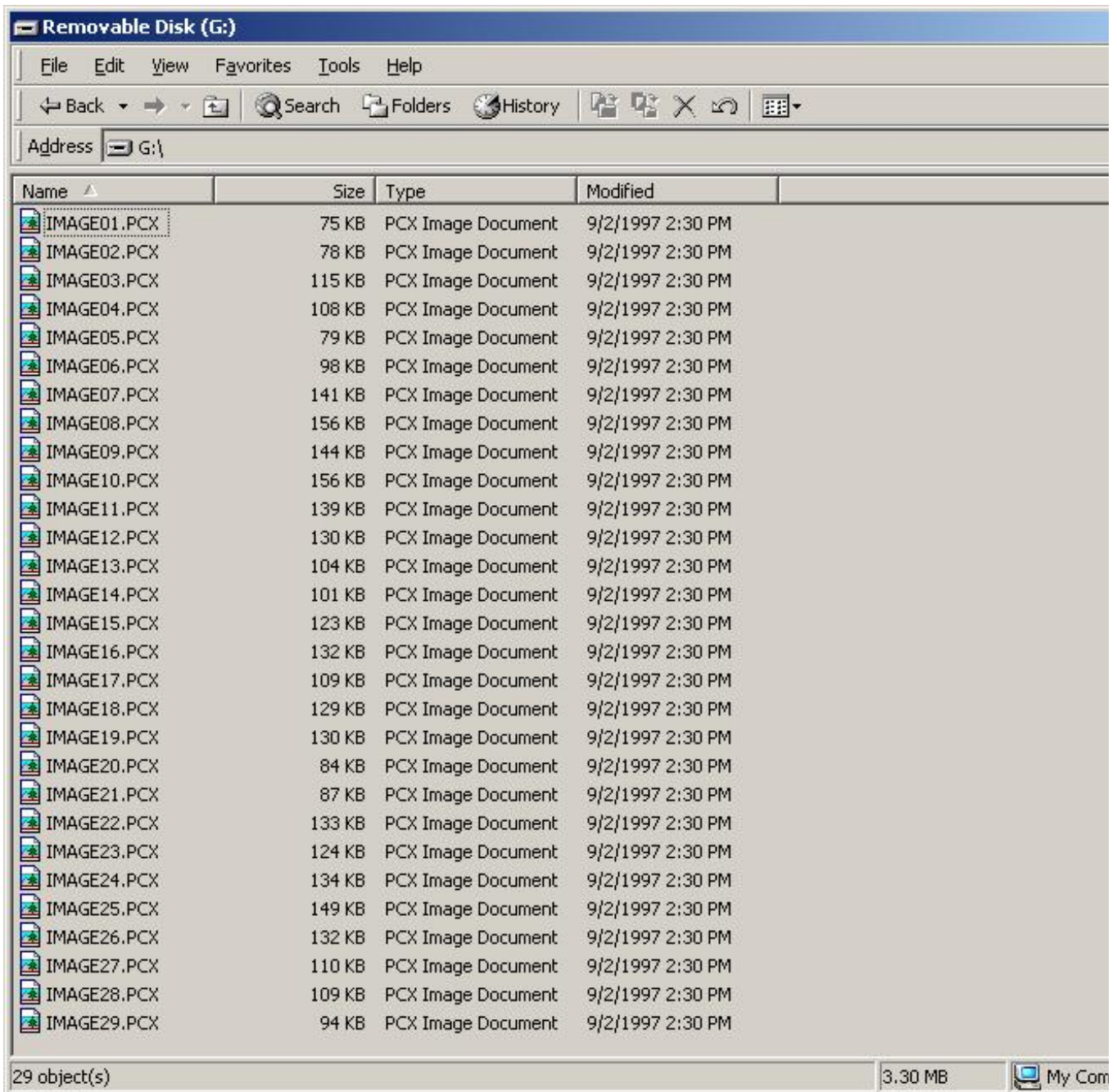

3.18.4 Read data from a computer

Once the flashcard has been recognized as a removable hard disk, any PCX or TXT file can be read from the computer:

- from the file explorer, double-click on a file to open it.
- from a standard image viewer (Imaging) or a text editor (Notepad), open a file with the File ->Open menu.

3.18.5 Copy data to the computer

To copy images and text files from the flashcard to the computer, just drag-and-drop the files to copy from the file Explorer to the destination directory.

3.18.6 Interface with PACS

PACS can be interfaced with SIGMA 110 or SIGMA 330 when using USB-Link™. In this case, data stored on the flashcard are imported and processed by the PACS. For more information about the PACS software refer to the User Manual of the PACS software delivered with the system.

Please contact your local KONTRON MEDICAL representative for information about supported PACS.

3.18.7 Limitations

Only read accesses are allowed. In consequence, the following are forbidden from the computer:

- no flashcard format,
- no file can be modified, or deleted,
- no file can be created or copied,
- no file can be renamed,
- no directory can be created,

The flashcard organization must be solely managed by the SIGMA. If one of the above listed actions are done anyway, then the SIGMA will not recognize these data and the PACS may not import them. Therefore, the flashcard must be formatted from the SIGMA: saved data are then lost.

The user will be responsible to preserve the flashcard content (no changes must be done from the computer, only read and copy operations are allowed).

All the files the SIGMA writes on the flashcard are read-only. But, if the user intends to modify or delete a file, the Operating System just warns him that the file is write protected, but the user can delete or modify it anyway.

3.19 SonoWin^B Lite and SonoWin^B Basic PACS

3.19.1 Overview

3.19.1.1 SonoWin^S Lite

SonoWin[®] Lite PACS¹ software offers the following features:

- ❑ Transfer of patient information data and images between the SIGMA 110/330 and the PACS
- ❑ Transfer of images in digital format (no loss of quality contrary to a frame grabber)
- ❑ Powerful database for fast patient sorting regardless the number of patients and images,
- ❑ Intuitive user interface and research criteria,
- ❑ Export and import of most commonly used image formats (.bmp, .pcx, .jpg, etc.),
- ❑ Fast access to images by a double click on images,
- ❑ Selectable backup frequency,
- ❑ Very reliable backup (impervious to dust, magnets, moisture, and shock) thanks to the Magneto Optical Disk drive and disk delivered with the software.



1. Picture Archiving and Communication System.

3.19.1.2 SonoWin^S Basic

In addition to SonoWin[®] Lite features, SonoWin[®] Basic PACS software offers:

- ❑ Transfer of calibration data and measurement between the SIGMA 110/330 and the PACS
- ❑ Flexible configurable report templates for reduced working time,
- ❑ Simple drag and drop to include images into a report.

3.19.1.3 Advanced features

Additionally, following options are available:

- ❑ Post Measurement Module for doing measurements on archived images
- ❑ DICOM-int for importing DICOM images
- ❑ DICOM-ext for exporting DICOM images

Please contact your local KONTRON MEDICAL representative for more information.

3.19.2 Start a Study

The correct assignment of individual data to a particular patient is based on a patient ID. This unique identification is entered in the host ultrasound device under the “FOLDER N” field of the patient ID page.



The simplest way to set up a new patient is to always create a patient record in SonoWin[®] first. Then, before starting a new study on the ultrasound device, it is essential to press the “New patient” icon  (this will reset all the biometry and patient fields) and store the generated patient ID in the “FOLDER N” field. The other patient data, such as name, date of birth etc., are then automatically and correctly assigned in SonoWin[®] and do not have to be entered again in the ultrasound device.

3.19.3 Save images, reports and patient information

During an examination, the operator can store patient data, report and images on a formatted PCMCIA SRAM. Images are stored when the “Store” key is pressed in any freeze menu.



Reports and patient information are stored from any biometry page or from the patient ID page when the “Store” key is pressed.



3.19.4 Transfer data to SonoWin^B

Once relevant data have been stored on the PCMCIA SRAM, the transfer can be done. As previously mentioned, SonoWin[®] supports two modes of operation: data transfer via PCMCIA SRAM card or via USB cable connection.

3.19.4.1 Transfer via a PCMCIA SRAM

When this operating mode is used, the SRAM must be inserted in the PCMCIA drive located on the computer. When SonoWin[®] is running, the system reads the relevant data on the card and the KIPRISM data are automatically stored in the correct SonoWin[®] records. When the PCMCIA SRAM is inserted again in the SIGMA, the memory card content is automatically erased.

Note that if certain measurements cannot be assigned automatically to SonoWin[®] measurement records (e.g. in case of user-defined measurements), the assignment can be performed manually. Please refer to “SonoWin[®]-2000 User’s Manual”.

3.19.4.2 Transfer via a USB connection

This operating mode is based on a USB cable connection between the ultrasound device and the computer. Unlike the operating mode described above, the SRAM card remains in its drive on the ultrasound device all the time.

There are several ways to start a transfer from the SIGMA to SonoWin[®]:

- press on the “Transfer” key in any freeze menu



The data currently stored on the memory card are transferred to SonoWin[®].

- start a new patient study: press on the new patient icon from the patient ID page



The data relevant to the previous patient are automatically transferred.

- power off the SIGMA: if KIPRISM data are stored on the SRAM, the operator is prompted to transfer data.



As soon as SonoWin[®] has successfully read all the information stored on the card, the input data will be automatically deleted from the SRAM card by the ultrasound device. If individual measurements cannot be assigned automatically, the procedure for the manual assignment is the same in this operating mode as in the mode described above.

Note that the following error message may be displayed by SonoWin[®] after having started.



This means that SonoWin[®] can not work because it has not full accesses to the PCMCIA card. The setup on PCMCIA card accesses must be modified in the preferences menu (“Setup”>”Prefs”>”System”>”PCMCIA card”) and the option “Full accessed” must be selected.



Selecting this option is absolutely essential otherwise (option “Read only accessed” is selected) the data transfer between the ultrasound device and the PC via a USB cable connection is not possible.

3.19.5 Data Assignment

This chapter is only valid for the Basic version of SonoWin[®].

Important note: any SonoWin[®] user with administrator privileges can change any data assignment and so this document may not be up to date compared to modified settings. Here only the default settings are described.

3.19.5.1 Assignment of KIPRISM data to existing SonoWin^S parameters

KIPRISM data are assigned to SonoWin[®] parameters using a conversion table. To check which values are assigned and which ones are ignored during this process, click on the KIPRISM icon  in the SonoWin[®] main window or select the menu item “Window” – “Kiprism”.

This opens a window displaying the results of the assignment process. Please refer to “SonoWin[®]-2000 User’s Manual” for more details.

3.19.5.2 Assignment of KIPRISM data to user-defined SonoWin^S parameters



Some KIPRISM data are not assigned to SonoWin[®] parameters. The user can assign them to an existing parameter in an existing chapter (see Section 3.19.5.1 on page 109), or create a specific chapter and/or a specific parameter. To do so, select the menu item “Window” – “Measured Values” or click on the corresponding icon  in the SonoWin[®] main window, and then select “Configuration” in the system menu.

Please refer to “SonoWin[®]-2000 User’s Manual” for more details.

3.19.5.3 Multiple Assignment of KIPRISM data to SonoWin^S parameters

One SonoWin[®] parameter may be mapped to more than one KIPRISM data (see Appendix K for a detailed list). The assignment of some measurements from SIGMA to the same SonoWin[®] value is intended, because mostly only one of these is used.

If, in rare case, there is a need for a customer to use two or more of these values simultaneously, he can assign them to user-defined measurements, and proceed as described below:

- Open the measurement table (click )
- Open “Configuration” in the system menu
- Mark the chapter where an item has to be add, or create a new chapter
- Add the item(s)
- Close this window.
- Assign the transferred values to the newly defined measurements, by clicking on  .

Please refer to “SonoWin[®]-2000 User’s Manual” for more details.

3.20 Integrated PC (SIGMA 330 Excellence)

3.20.1 Overview





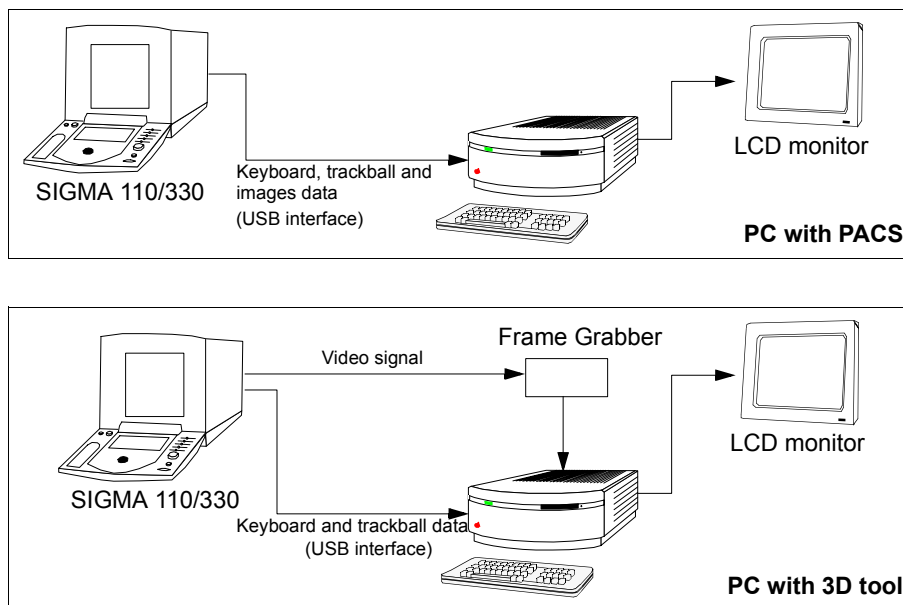

The SIGMA 330 Excellence includes a high-end PC running Microsoft® Windows® 2000 Professional; the keyboard and trackball of the SIGMA can be used as a standard PC keyboard and PC mouse; the Universal Serial Bus (USB) interface is used to perform the communication link between the SIGMA system and the integrated PC.

The following drawings show the PACS configuration and 3D tool configuration:



3.20.2 SAFETY PRECAUTIONS

Please review the information in this section before using the Integrated PC. Please also review the information in the user manuals of the 3D and/or PACS software.

-  Maintenance, service, changes of the device, installation, upgrades, setups may only be performed by KONTRON MEDICAL trained and authorized personal. Warranty might be void.
-  Technical documentation is worthless without adequate training. Please contact KONTRON MEDICAL for further information.
-  DO NOT INSTALL ANY OTHER SOFTWARE. Contact your local KONTRON MEDICAL representative if you want to install software.
-  Do only use accessories and replacements which are recommended by KONTRON MEDICAL.
-  Do not remove disks from the disk drive (optional) during disk read and write operations (when the disk drive light is on). Removing a disk during read and write operations can cause incomplete storage of data files, resulting in data loss.
-  KONTRON MEDICAL is not responsible for problems attributable to unauthorized changes, additions or deletions to KONTRON MEDICAL software or hardware, or unauthorized installation of third party software.
-  KONTRON MEDICAL is not responsible for loss of data; KONTRON MEDICAL recommends that you back up regularly your data.

3.20.3 Entering PC remote control mode

In standard mode, SIGMA keyboard and trackball control the ultrasound system. A specific key sequence has to be entered on the keyboard of the SIGMA to remote control the PC: **SHIFT+SELECT**.

Once in PC remote control mode, trackball actions and most of the keyboard actions are sent to the PC like a standard mouse/keyboard. When the user switches to PC mode keyboard, a specific menu is displayed on the SIGMA screen.

3.20.4 PC remote control features description

The trackball emulates a three buttons mouse.

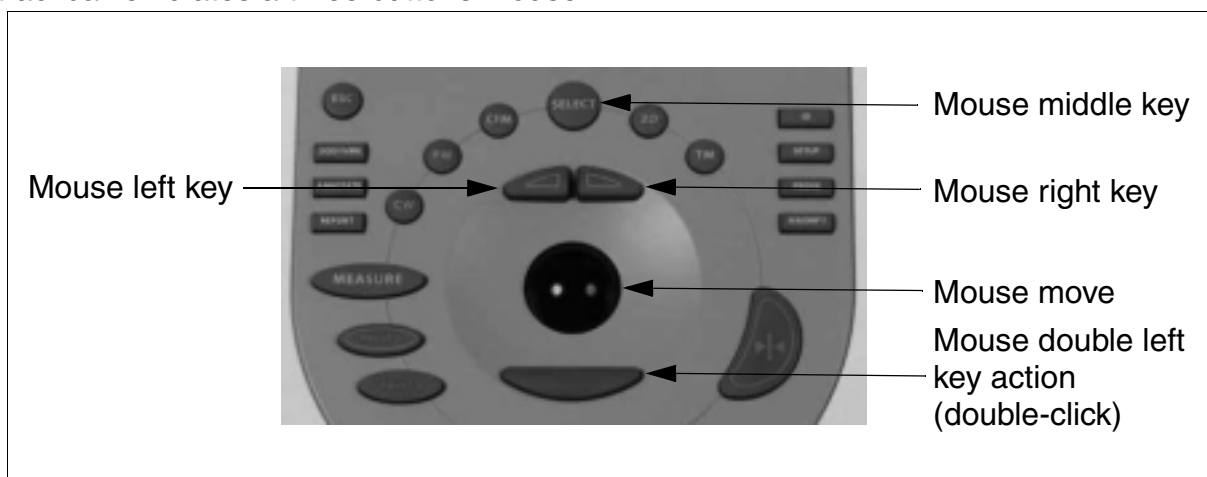

3.20.5 Leaving PC remote control mode

PC remote control can be left at any time by pressing **SHIFT+SELECT, F5** or **FREEZE**.

3.20.6 Keyboard in PC mode

3.20.6.1 Introduction

This section defines the use of the SIGMA keys in PC mode. In PC mode the SIGMA keyboard becomes a PC one, but some keys are still affected to SIGMA functions.

3.20.6.2 SIGMA keys

The following keys remain assigned to the SIGMA:

- ❑ Sliders,
- ❑ B-gain, D-gain,
- ❑ DEPTH,
- ❑ PRINT 1,
- ❑ FREEZE,
- ❑ MENU and POWER OFF

3.20.6.3 PC keys

Four set of keys can be distinguished:

- ❑ standard keys as letters and digits.
- ❑ control keys as CTRL, ALT.
- ❑ “menu keys” allowing access to function keys and some special characters.
- ❑ trackball keys and events.

The following scheme shows a SIGMA keyboard with, in white, the keys used for the PC keyboard and trackball, and their affectation. The keys in grey are not used for the PC keyboard and trackball but for the SIGMA as usual.

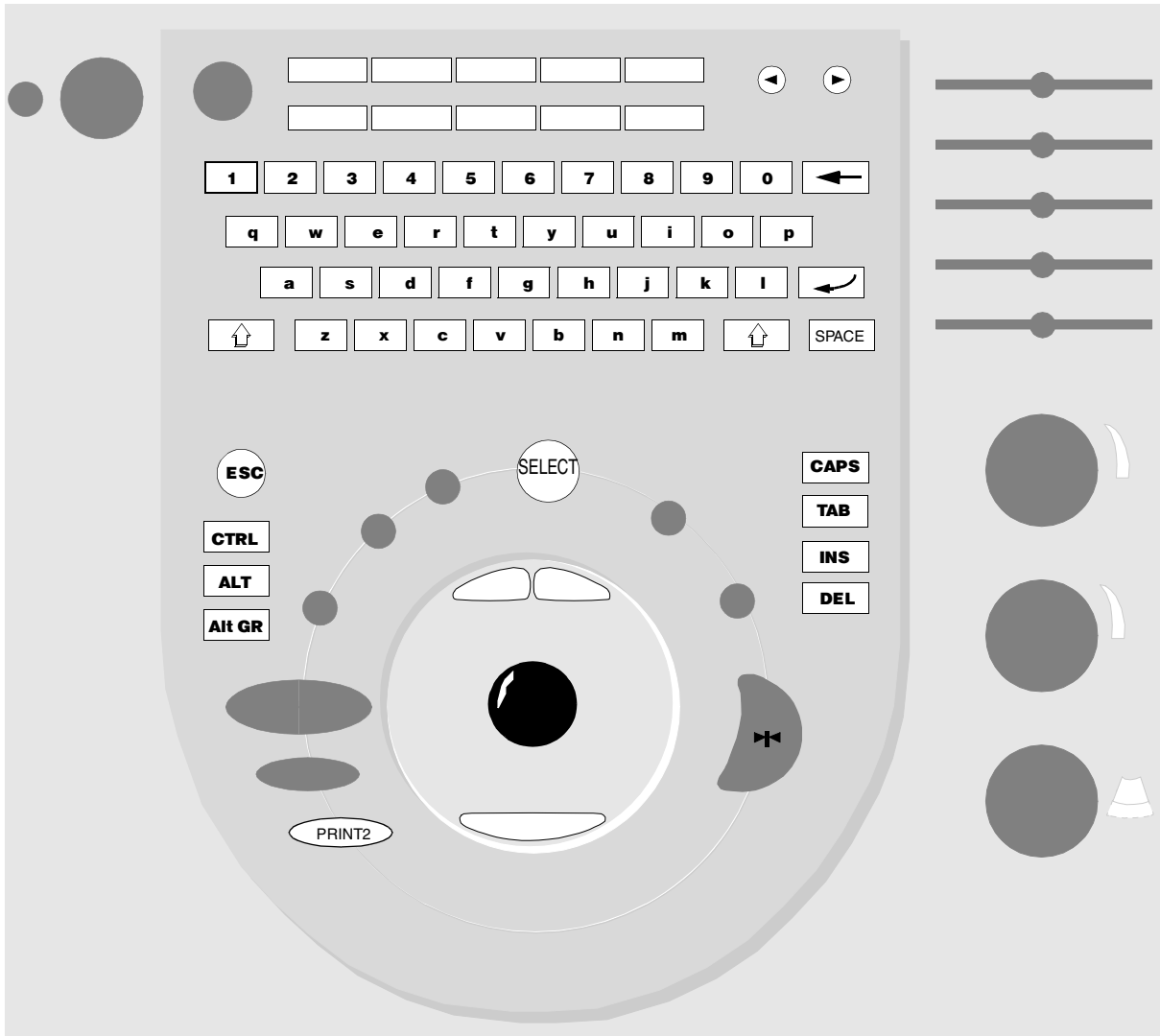

Menu keys

The menu keys allow to access the keys which are not accessible directly from the SIGMA keyboard or are not intuitive enough. They allow also to hide such application specific key combinations.

They are presented on 2 menu pages:

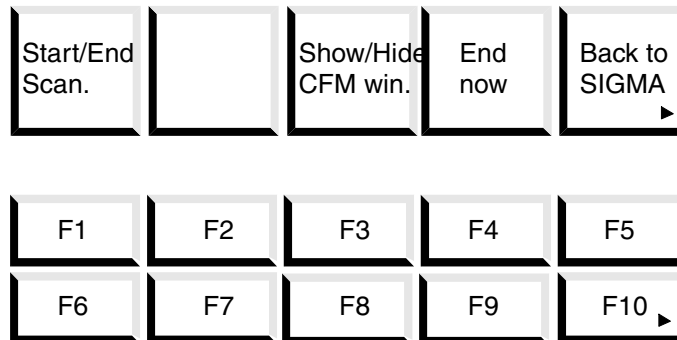

Application specific menu key can help the user by allowing direct access to complex key sequences or specific controls. These specific keys are:

- Start / stop scan, Used by 3D software
- Show/hide CFM window. Hide or show CFM window and wall filter marker.
- End now Ends the shut down process without waiting for the PC shut-down (only valid in a shut down sequence).

WARNING: use this key with care. Hard disk of the PC can be damaged and open files will not be saved.

Shift keys

Using shift key combination allows access to country specific codes.

Lower, upper case

Usually, we use the shift key combination to select an upper case character. Here on the SIGMA keyboard the user must press **CAPS LOCK** key to select upper case mode and then press it again to go back on lower case mode.

Print 2 key

This key is affected in PC mode to send a print command to the active application.

3.20.6.4 Stickers for Keyboard

Keys as CTRL and ALT are frequently used in a PC user interface, so they have to be found easily on the keyboard. Their affectation is indicated on the keyboard by using stickers as shown below.



3.20.7 Errors and warnings

When the user intends to enter the PC mode and when no PC has been detected on the USB port a warning message is displayed. For more information, refer to Chapter 5.4.4.16, "Warning 25: No PC connected to USB port", on page 5-17.

3.20.8 PC power on

The integrated PC starts automatically when the system is powered on. When the following window is shown the user has to press on **CTRL+ALT+DEL** and enter his user name and password in



the LOGIN window. The default user name is "sigma" with the "sigma" password.



Please contact your local KONTRON MEDICAL representative to change the user name and/or the password or to log on the system as "Administrator".

3.20.9 PC power off

During the shut down process requested by the user, commands are sent throughout the USB interface. SIGMA sends a **CTRL+ALT+DEL** key sequence to the PC and then waits for the PC shut down completion. At this moment the user is responsible of closing and saving his documents. He can use the SIGMA keyboard and trackball which are automatically affected to PC mode. Select "Shutdown" in the different dialogues displayed.



When the PC has finished its shutdown process, the SIGMA system is automatically powered off.

3.20.10 3D VascularView and 3D FetalView

The settings have been specially adapted to easily control the 3D software directly from the SIGMA, using menu keys or the footswitch. This chapter describes only these shortcuts.

For more information about the 3D software refer to the User Manual of the 3D software delivered with the system.

3.20.10.1 Menu keys

Refer to “Menu keys” on page 3-113.

3.20.10.2 Foot switch

The foot switch allows the user to send some commands to the SIGMA. In PC mode the two buttons are affected according to the following:

- acquisition mode:
 - left button -> nothing
 - right button press event -> start scan and stop scan
- review mode (when acquisition is stopped):
 - short step (< 1 second) on the right button -> open save dialogue,
 - long step (> 1 second) on the right button -> open delete dialogue,
 - step on the right button -> OK
 - step on the left button -> CANCEL

3.20.11 PACS option

For more information about the PACS software refer to the User Manual of the PACS software delivered with the system.

3.20.12 Connection to a Network

The SIGMA 330 Excellence provides a RJ-45 10/100 Mbps Ethernet connector. Please contact your local KONTRON MEDICAL representative to change the parameters of the Network connection.



Never connect Network (RJ-45) directly to the system; use a medical grade network isolator which must comply with IEC 601-1 specifications. Wrong connections may compromise the electrical safety of the system. KONTRON MEDICAL provides a medical grade isolator on request, see Chapter 6.3, Accessories, on page 6-5 for ordering.

3.20.13 Installation of peripherals

Please contact your local KONTRON MEDICAL representative to install peripherals on the system.



Never connect additional peripherals directly to wall outlets; use the outlet available in the cart or a medical grade isolating transformer which must comply with IEC 601-1 specifications. Wrong connections may compromise the electrical safety of the system. KONTRON MEDICAL provides a medical grade isolating transformer on request, see Chapter 6.3, Accessories, on page 6-5 for ordering.

This page is intentionally left blank

4. MAINTENANCE

4.1 Cleaning

4.1.1 Probes

It is recommended that all probes be cleaned, adequately disinfected between patients. Gently clean the probe with a very mild detergent solution and a slightly dampened cloth. Do not apply pressure.

Never immerse the probe in any liquid, except for disinfection (see Chapter 4.2, “Disinfection”, on page 4-5).

4.1.2 TV Monitor

Caution, TV Monitor screen includes an anti-reflecting coating.

For cleaning, spray anti-static screen cleaner (e.g. cleaning products for computer), wiping with soft wiper.

4.1.3 EYE-Q 300M Monitor

- For cleaning monitor cover it is recommended to use Johnson Glass Clue; it is possible to use Alkaline cleaner or IPA (Isopropylalcohol).
- For cleaning monitor panel it is recommended to use Sanwa CD-41NT.
- For cleaning monitor air filter any IPA can be used.

4.1.4 Keyboard

The top grid and the silicon layer of the keyboard and the trackball can be easily removed for cleaning; they are washable.

To remove the grid, press it as shown in figure 4-1, “Keyboard Cleaning”, on page 4-3 and pull it forward. Then, the silicon layer and the trackball are accessible.



Figure 4-1: Keyboard Cleaning

4.1.5 Instrument

Clean the surface of the SIGMA 110/330 with a dry cloth. If more extensive cleaning is required, switch off the instrument and disconnect the power cord. Use a slightly dampened soft cloth and very mild detergent solution to clean exterior surfaces.

Never use strong solvents, slosh water on the instrument, or immerse any part of the instrument in any liquid.

Never remove the protective covers of the SIGMA 110/330. Hazardous voltage levels exist.

If more extensive cleaning is required, contact your Customer Service Representative.

4.2 Disinfection

It is recommended that all probes be cleaned, adequately disinfected between patients.

All probes may be disinfected with Cidex[®] 1.

The recommended duration for disinfection is 10 minutes.

For detailed information on disinfection of probes and duration of disinfection refer to the probes manufacturer's recommendations.

For special applications and specific transducers refer to their proper Operating Manual.

The following figure shows the immersible part for the different probe types

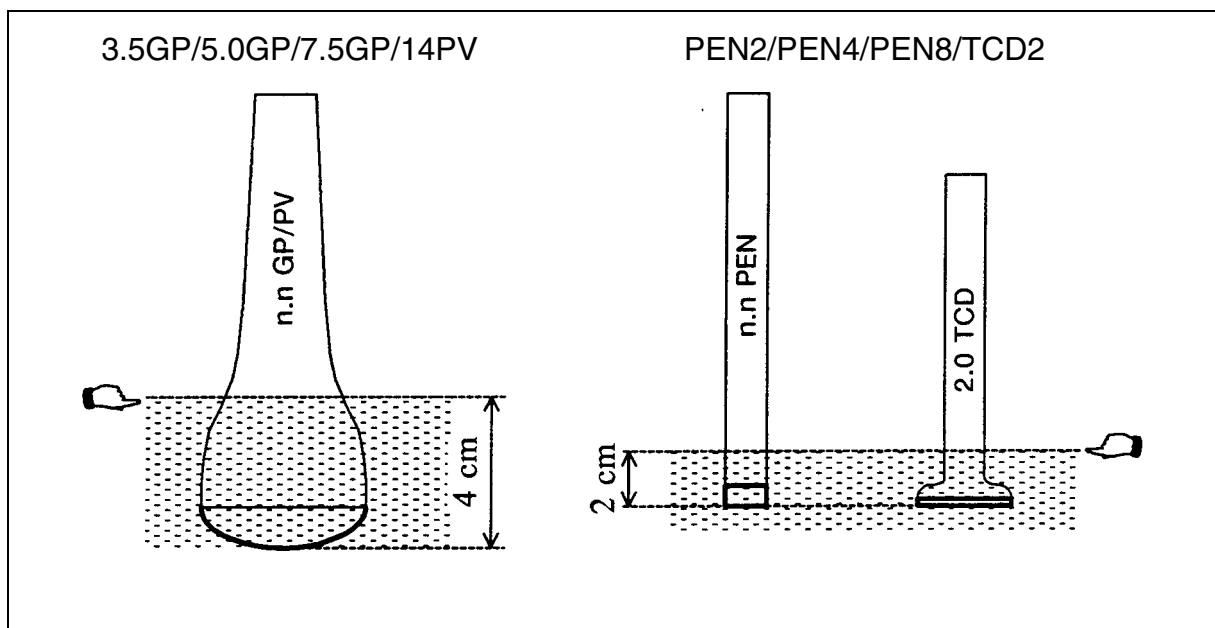

Figure 4-2: Immersion limit of Annular Sector and Pencil probes

1. Cidex[®] is a Trademark of Johnson & Johnson

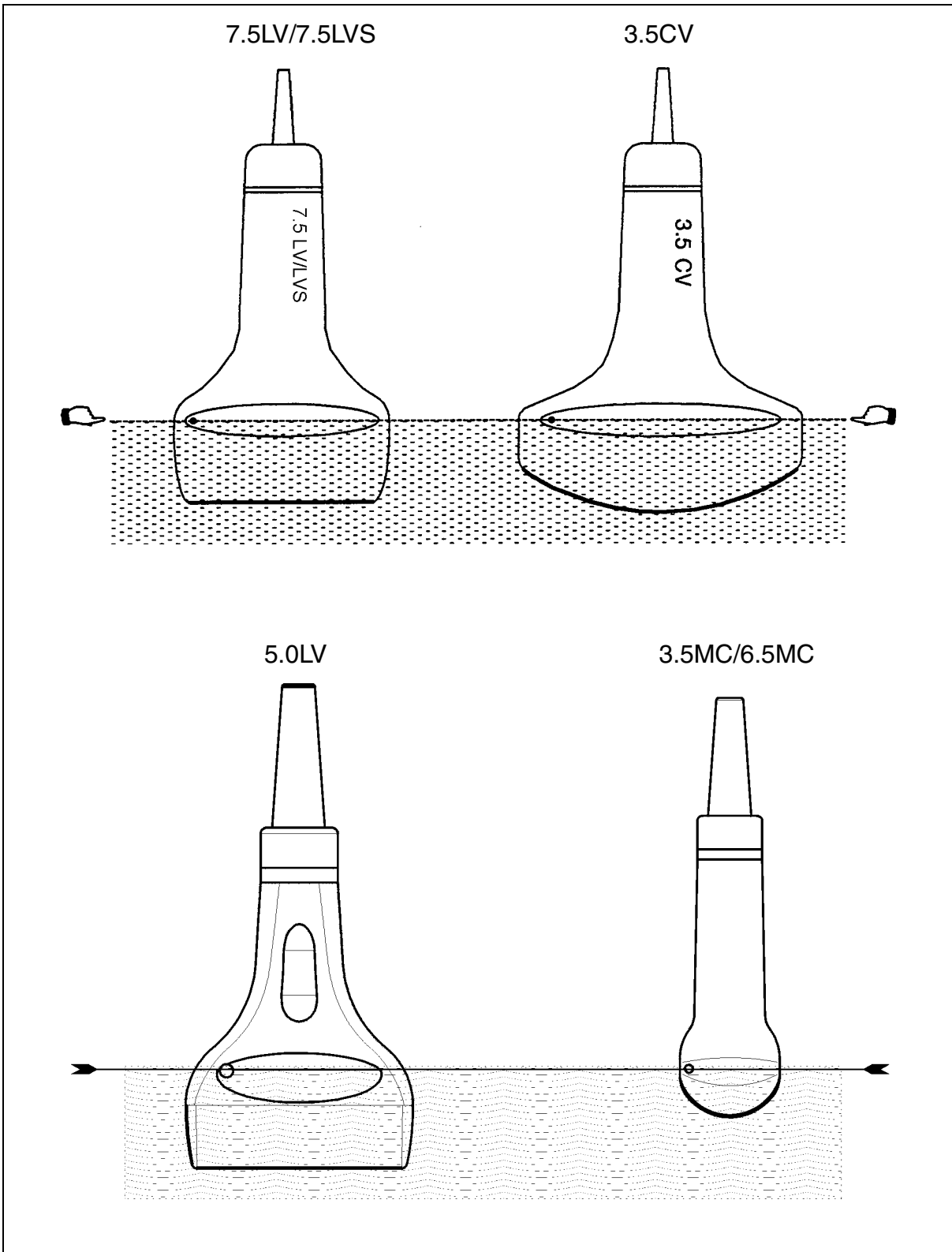

Figure 4-3: Immersion limit of Linear/Convex probes

6.5MR/6.5VMC/6.5EV

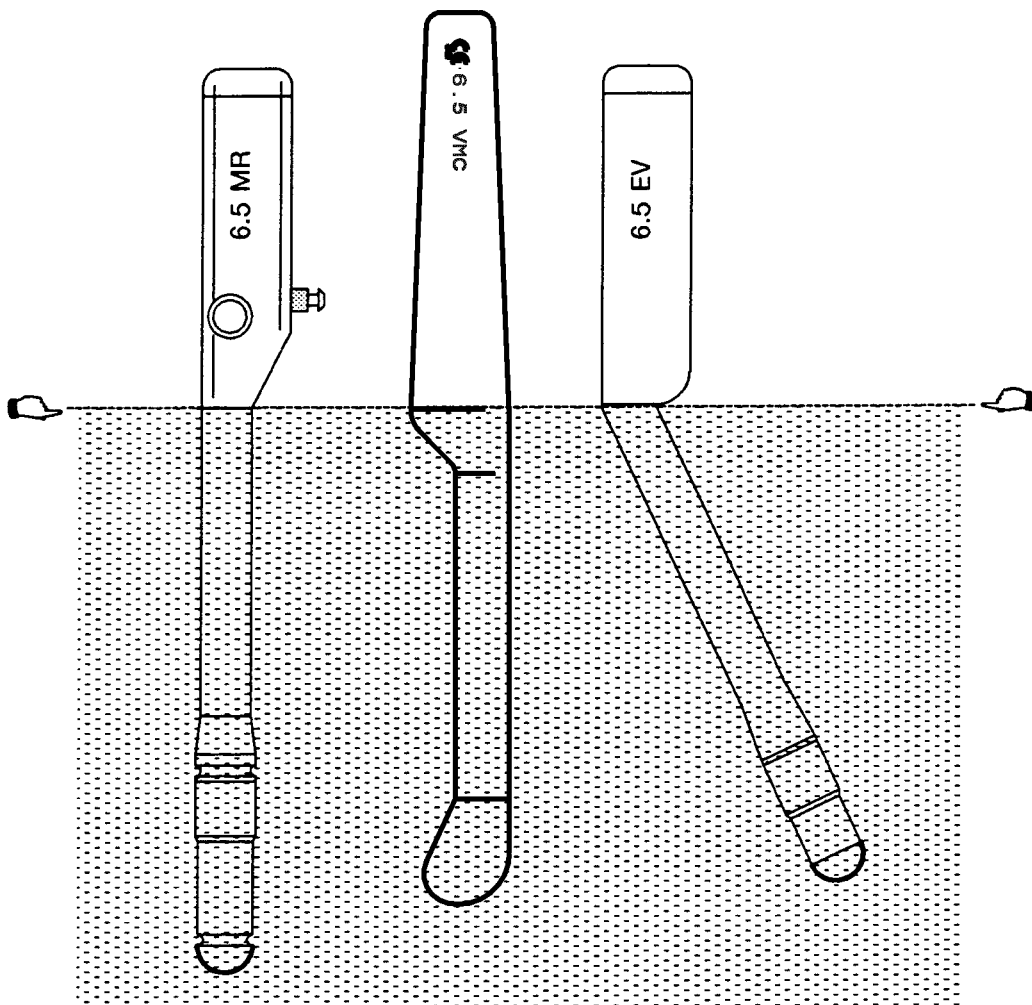

Figure 4-4: Immersion limit of endocavitary probes

4.3 Repairs and Maintenance

The SIGMA 110/330 system is designed to be maintained by factory-trained Customer Service Representatives.

The manufacturer, assembler, installer or importer considers himself responsible for the effects on safety, reliability and performance of this product only if:

- Assembly operations, extensions, readjustments, modifications or repairs are carried out by personnel authorized by the Manufacturer.
- The electrical installation of the facility where the product is used complies with the IEC requirements or Electrical Codes of the country.
- The product is used in accordance with the instructions of use.

4.3.1 User Maintenance

The user of SIGMA 110/330 units can do some maintenance by himself.

4.3.1.1 Air filter replacement

Depending on the system configuration and on the environmental conditions, it is necessary to replace the air filter more or less regularly:

- When working in non polluted environments, the air filter must be replaced twice a year.
- When working in very polluted environments, it must be replaced every month.

It is mandatory to replace the air filter when the "Warning 18" is displayed.

Note that a worn and cleaned filter will never be as efficient as a new one.

It is recommended to replace the filter by the KONTRON MEDICAL genuine part (PN: 471059).

The air filter is located on the backside of the instrument. To replace it:



Figure 4-5: Air filter replacement

- Pull on the air filter grid as shown on the figure 4-5 to remove it.
- Remove the used filter.
- Place the new one.

- Position back the air filter grid.

4.3.1.2 *Remote Control Unit*

The Remote Control Unit is powered by two "LR03.AAA.MN 2400" batteries. Replace batteries only with batteries of the same type.

4.3.2 Manufacturer Maintenance

A yearly maintenance visit is advisable. It should be carried out by personnel authorized by the Manufacturer.

4.4 Product Recycling and Disposal

The SIGMA 110 and SIGMA 330 contains electronic boards, batteries and tubes.

Before you dispose the system, these boards, batteries and tubes must be removed and discarded according to local regulations or recycled where facilities exist. Contact your local KONTRON MEDICAL company or agent for further informations.

For battery disposal contact your local waste disposal facility.

5. TROUBLESHOOTING

5.1 Handle Error and Warning Messages

This troubleshooting procedure lists the checks for remedying simple defects. Extensive troubleshooting is explained in the technical service manual and is only performed by the local service engineer.

Points to check by the user to avoid Error and Warning Messages:

- Check control settings. Incorrect control settings may suggest a fault that does not exist. If there is any question about the correct function of any control, consult Sections 2 and 3 of this manual.
- Check connections and fuses.
- Check cables for proper interconnection.
- Disconnect the unit from the power source and check the fuses in the power source receptacle (if the receptacle is fused).
- Check monitor operation.

5.2 Introduction and Rules

This chapter contains a description of the different warnings and errors managed by SIGMA 110/330.

5.2.1 Rules

Warnings and Errors messages are written:

- in a dialogue box

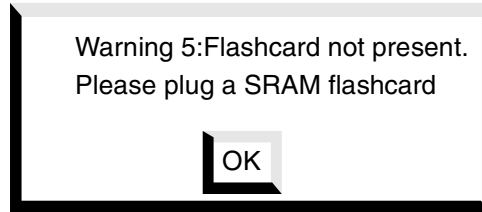

- directly on the screen (in red on colour monitors)
example: NO ECG is written on the bottom right side of the screen

5.2.2 Definition

Different terms to qualify the displayed messages are used in this document:

- Status messages: have no effect on the system, but inform the user of a bad manipulation.
- Warnings: signify to the user that the system is in an incorrect state, or that the user has performed a non authorized action.
- Errors: inform the user of a system failure due to hardware problems (broken board) or software failure.

5.2.3 Remarks

- The different messages (warnings and errors) are displayed in English.
- Doppler board is either SP_DOP or COL_DOP board

5.3 Status Messages

5.3.1 ECG

When ECG mode is active different error cases can be detected: the different ECG warning messages are always displayed on the bottom right side of the screen in red.

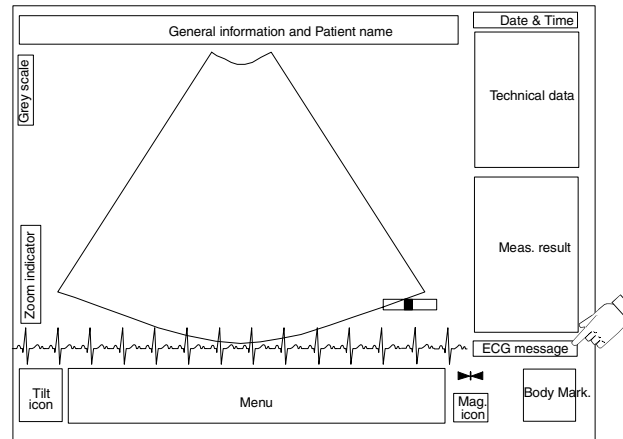

5.3.1.1 ECG Activation

There are two ways to activate the ECG mode the user should:

- load the cardio setup for the current probe
- switch the ECG ON via the PREF menu

5.3.1.2 NO ECG Message

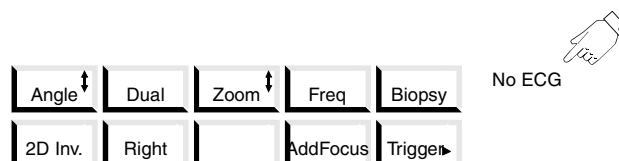

NO ECG is displayed when ECG mode is active and

- ECG is not connected or not correctly connected
- there is a defect serial port on the SIGMA
- there is a defect ECG

To correct this problem the user should verify the ECG connection, if the problem persists he should call the service team.

5.3.1.3 LEAD OFF Message

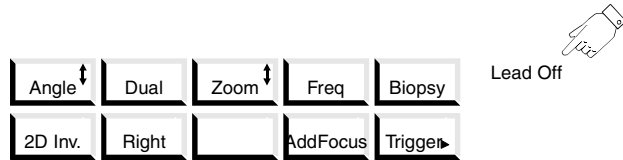

LEAD OFF is displayed when ECG mode is active and

- clamps are defective
- clamps are not correctly set on the patient
 - Red clamp on right arm
 - Yellow clamp on left arm
 - Black clamp on right leg

To correct this problem verify the clamps position on the patient or verify the clamps, or call the service team, if the problem persists.

5.3.1.4 BAD ELECTRODE Message

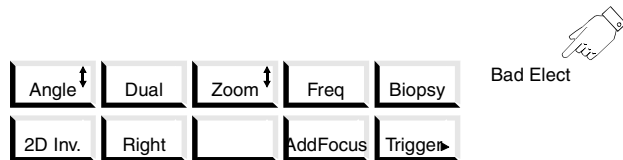

BAD ELECTRODE is displayed when ECG mode is active and

- clamps are defective
- clamps are not connected

To correct this problem connect the clamps to the patient or verify the clamps, or call the service team, if the problem persists.

5.3.1.5 ECG ERROR Message

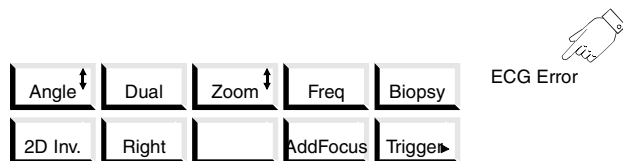

ECG ERROR is displayed when ECG mode active and a failure in the ECG software module happens.

To correct this problem, freeze and unfreeze the system. Call the service team, if the problem persists.

5.3.2 Measurement and Biometry

5.3.2.1 Invalid Results

Software performs checking of measurements for proper range before displaying results.

- Out of range measurement result
The “out of range” result is displayed with question marks (?) or sharp marks (#).

1 D	###.## mm
BDP	11.5 mm
EFA	??w?d

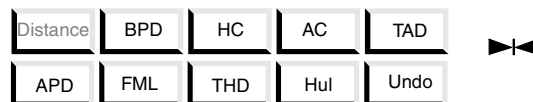
In this case the user restarts the current measurement, to have a valid result (denominator equal to 0, or too high measurement result).

- Out of range Ob/Gyn biometry result
The current measurement result is out of range for the foetal age computation.

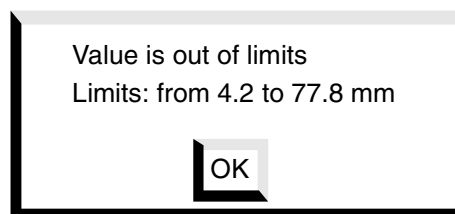

In this case the user restarts the current measurement, to have a valid result.

- Invalid biometry result
An invalid result (negative computed mass, invalid date, ...) is displayed as ###.## or ### according to the result type.

5.3.2.2 Other Cases

When restoring users preferences from flash card, the compliance of the restored data is checked. In case of incompatibility (inconsistent values restored) the following message is displayed:

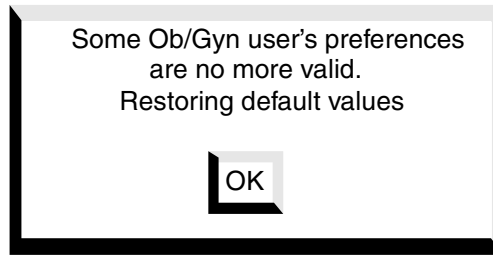

5.3.3 Transmit Voltage Indicator

This symbol message (TVI) warns the user that the Transmit High Voltage for probes is out of range. If the message persists, contact your local service representative.

In live mode, the system continuously checks the probe high voltage in all modes except in CFM while the probe voltage continuously changes from the 2D voltage to the Doppler voltage.

When the Probe high voltage is outside the limits, the high voltage warning icon is displayed on screen.

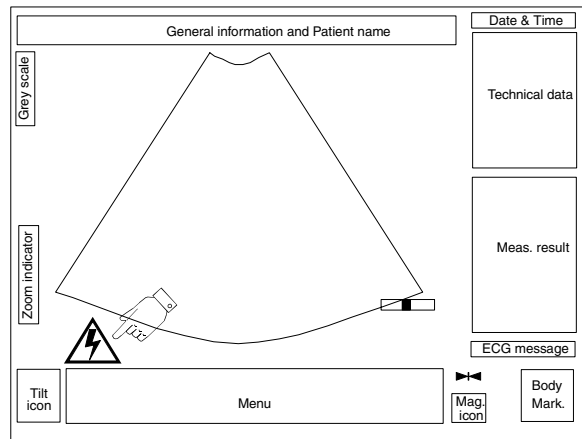

The first time the problem occurs the **Warning 24: Transmit Voltage is not under control** is displayed (see page 5-16)

5.4 Warnings

5.4.1 Start-up checks

5.4.1.1 Transducer Check

At system start-up or for each transducer change, the current plugged transducers codes are checked according to the current recognised transducers list.

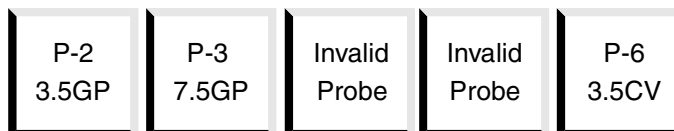

If one of the plugged transducer is not included in this list, on the probe menu “Invalid Probe” is displayed instead of the current probe name, or the transducer name is displayed in grey.

- Transducer name is displayed in grey, when:
 - the user wants to use a pencil probe without a Doppler board
 - a PEN 2 MHz transducer is plugged without the Cardio option.
- “Invalid Probe” can be displayed if:
 - the current probe is not recognised by the system (transducer no more or not currently available)
 - bad transducer code is read due to probe or transducer cable defect
 - the connector on the system is broken or has contact problems
 - LA DSP sends bad transducers codes

If one of the both message persists, the user must inform the service team.

5.4.1.2 Warning 0: NOVRAM reset

After a software upgrade the non volatile RAM (NOVRAM) is reset to guarantee its content. So before upgrading the software, the current configuration will be saved on the delivered flash card or SRAM (menu <SETUP>, <PCMCIA CARD>, <BACKUP CONFIG>), and restored after software upgrade (menu <SETUP>, <PCMCIA CARD>, <RESTORE CONFIG>).

Note: the restore operation can not be done for a version below V5.00 (i.e. V2.50) to a V 5.XX version (*Chapter 5.5.2, Error 1: Can not restore backed up configuration* on page 5-18)

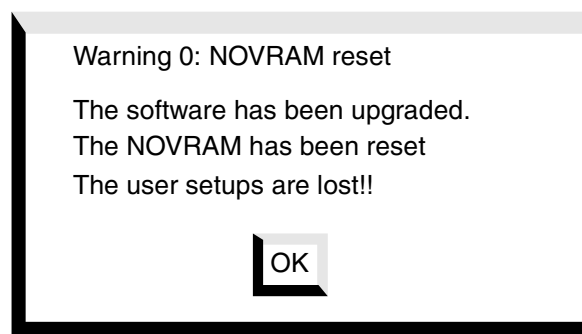

5.4.1.3 Warning 1: Backed up RAM reset

Two different cases can involve a backed up RAM (NOVRAM) reset:

- the backed up RAM content is corrupted (checked at system start-up)
- failure in the backed up RAM battery

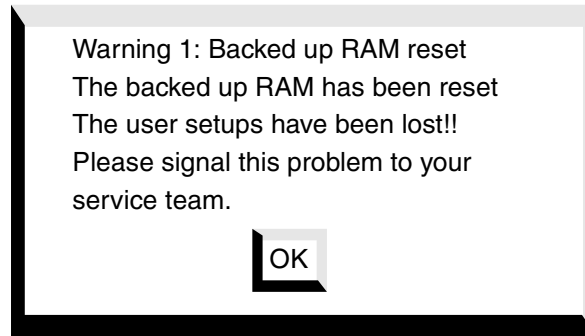

5.4.1.4 Warning 2: Transducer handling advise

Unplugging a transducer in live mode may generate some damages on the transducer or on the board, so when the user unplugs the current transducer in live mode the following message is displayed and the system is frozen.

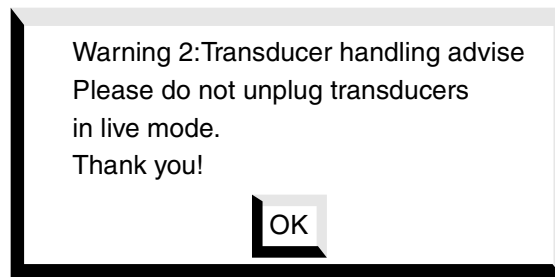

Remark: this message can be displayed when the transducer cable is broken (can not read the transducer code).

5.4.2 System Configuration Check

5.4.2.1 Warning 3: Hardware board version

During system start-up a check of the different available boards revision (software version dependant) is made. If one of the board (VLCUS, LA, COL_DOP/SP_DOP) is not in the list of the current available board revision, a warning message is displayed just after system start-up to inform the user that one or more of the board should not be used with this software version.

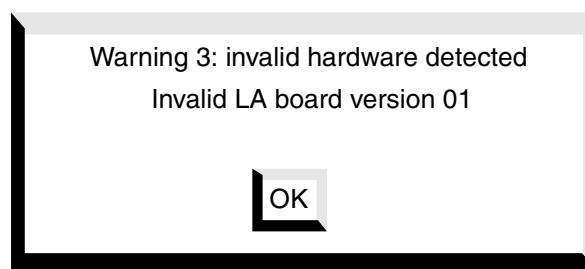

By pressing on any key, the dialogue box disappears.

This message is displayed at each system start-up until the invalid board is modified or replaced by the service team.

5.4.2.2 *Warning 4: Invalid system configuration*

For each type of system a list of the available boards is defined. At system start-up, the different boards are checked according to the current type, if some boards are found that are normally not included in this system type, a warning is displayed.

e.g: system type: SIGMA 110 Light on which no COL_DOP board should be connected

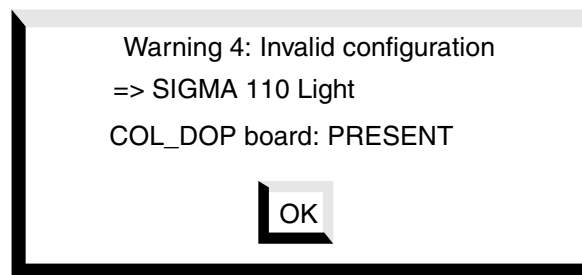

This message is displayed at each system start-up until the non authorized hardware is removed by the service team.

5.4.3 **Flash card and SRAM**

5.4.3.1 *Warning 5: Flash card not present*

Displayed when trying to store images without a flashcard plugged. A SRAM should be plugged

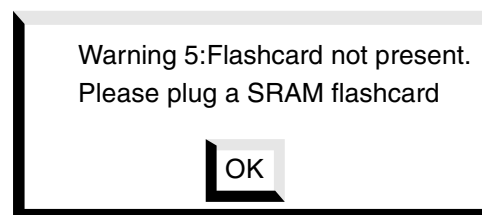

5.4.3.2 *Warning 6: Flash card is write protected*

The current plugged flash card is write protected, the user should change the flash card or remove the write protection.



5.4.3.3 Warning 7: SRAM battery status

The SRAM battery state is checked when the user plugs a SRAM. If the SRAM battery is low or empty, one of the following message is displayed and the user should replace the battery

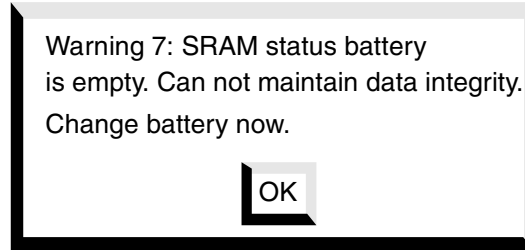
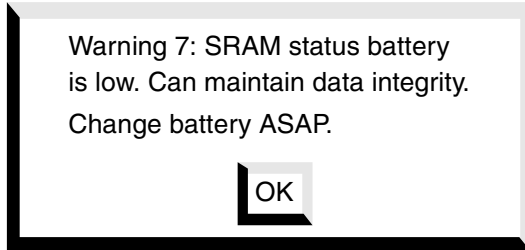

When the second message is displayed (empty battery), the saved data could be lost. The battery state can also be checked, via the PCMCIA menu.

5.4.3.4 Warning 8: No data to restore

This warning is displayed when the user tries to restore a configuration from an empty flashcard.

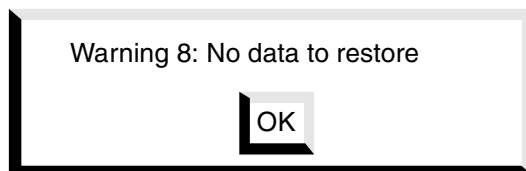

5.4.3.5 Warning 9: Invalid flashcard for archive

A formatted flashcard is plugged instead of a SRAM and the user wants to archive images. A SRAM must be plugged.

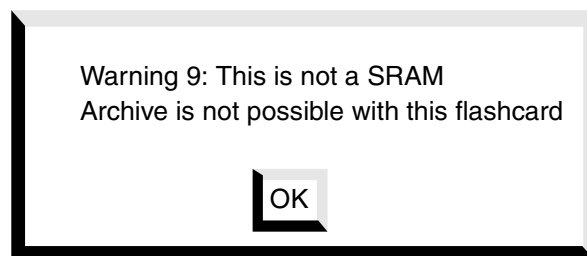

5.4.4 Miscellaneous checks

5.4.4.1 Warning 10: Invalid VLCUS serial number

This warning message is displayed at start-up if the serial number of the VLCUS board is not correct.

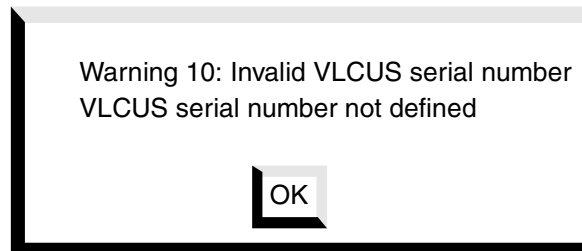

If the message persists, the user must inform the service team.

5.4.4.2 Warning 11: Printer not responding

This message is displayed when the printer is not responding. The user must check the printer (broken printer, printer Off, ...), the printer cable.

If the problem persists, the user must inform the service team.

5.4.4.3 Warning 12: Invalid configuration key

This message is displayed when the user enters an invalid configuration key from the preference menu.

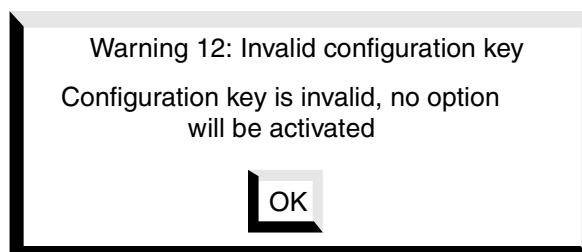

5.4.4.4 Warning 13: Name for a label list already exists

This message is displayed when the user enters a label list name that already exists.

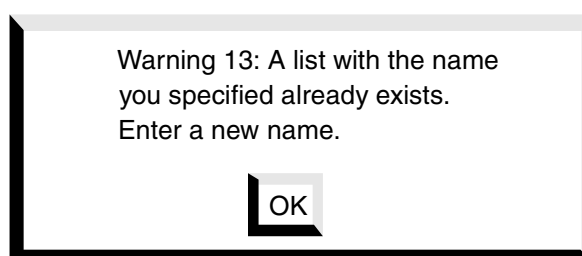

5.4.4.5 *Warning 14: EasyPrint option is no more available*

This message is displayed when the EasyPrint option has been temporary set (with a service dongle) and is no more available. This message is displayed after the start-up.

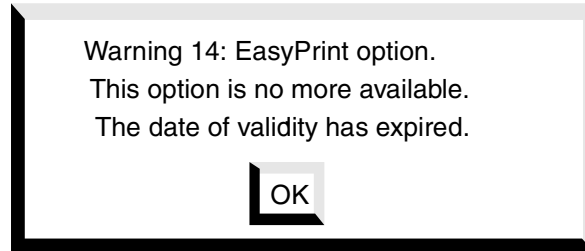

5.4.4.6 *Warning 15:*

This message is displayed when anyone tries to change the date of any “not for sale” version. A checksum to test software data integrity has been implemented to prevent hazardous modifications.

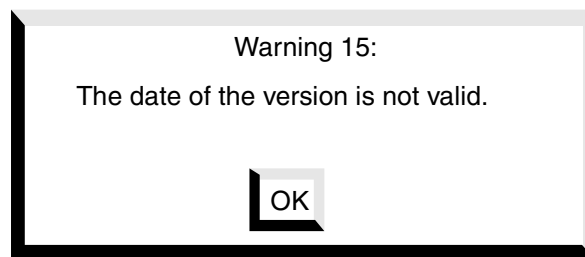

5.4.4.7 *Warning 16: Invalid time renting key*

This message is displayed when an invalid time renting key is entered.

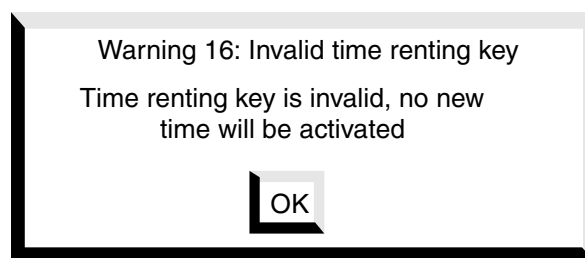

5.4.4.8 *Warning 17: Invalid time or date*

At start-up, the system check the date and the time. If one of both is invalid then this message is displayed to indicate that the date and time must be updated.

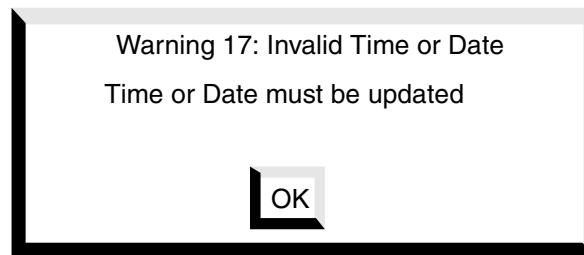

5.4.4.9 *Warning 18: Internal temperature too high*

Periodically, the system checks for its internal temperature. If a too high temperature is measured for a long period the following message will be displayed..

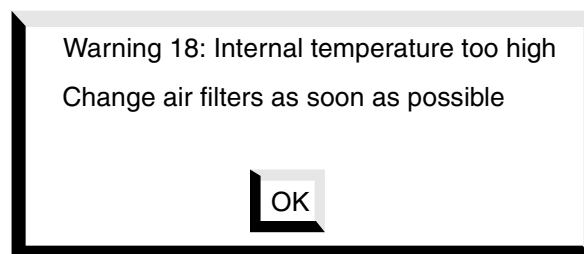

It is displayed each 5 minutes until the internal temperature returns to a acceptable temperature (below 65°C). This message is also displayed at system power up, if the internal temperature is too high (65°C or more)

5.4.4.10 *Warning 19: Time renting usage has expired*

The following message is displayed when the usage duration has expired: the system is locked until the user contacts the sales service to buy new hours.

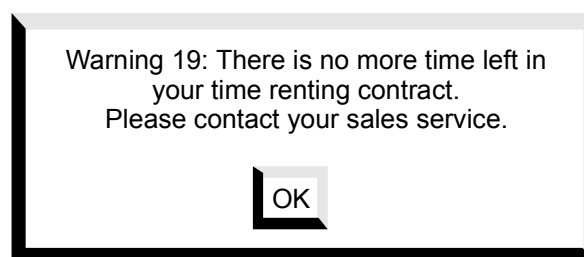

5.4.4.11 *Warning 20: Internal temperature too low for mechanical transducers*

To prevent damages on mechanical transducer, this warning is displayed if internal temperature is too low (below 16°C).

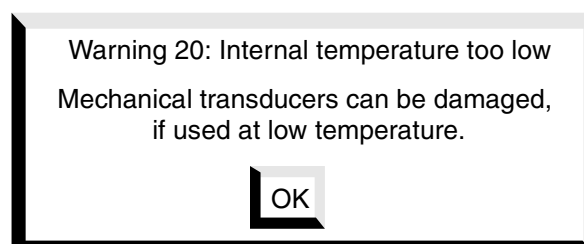

Note: the system temperature is displayed in the System Info.->Boards window.

5.4.4.12 *Warning 21: File is too long*

This warning is displayed when the image file to save on the flashcard is too long (greater than 192 kB).

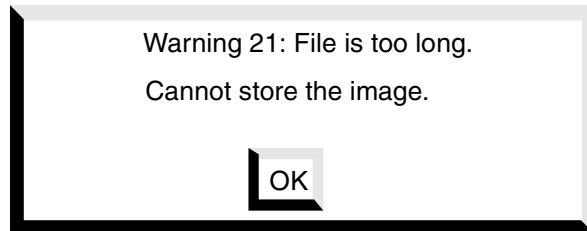

5.4.4.13 *Warning 22: Not enough place on SRAM*

This warning is displayed when there is no more room on the flashcard to save a file (image, report save, ...).

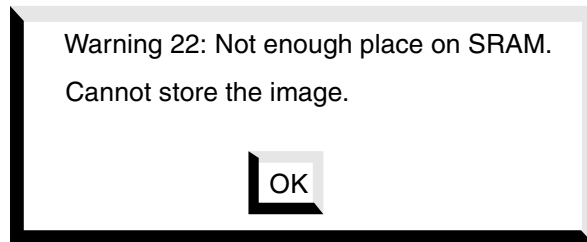

5.4.4.14 *Warning 23: Undefined Patient Name*

This warning can be displayed only when the KIPRISM option is on. It is displayed the first time an image is saved with an undefined patient name.

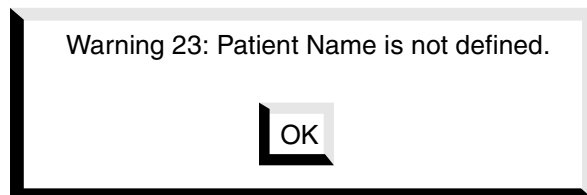

5.4.4.15 *Warning 24: Transmit Voltage is not under control*

This warning is displayed the first time the probe high voltage check fails (see Chapter 5.3.3, "Transmit Voltage Indicator", on page 5-8).

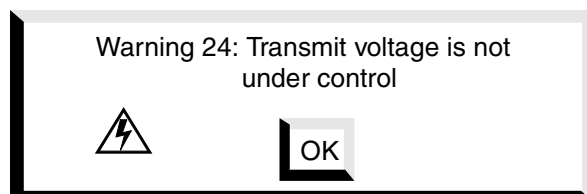

5.4.4.16 Warning 25: No PC connected to USB port

When the user intends to enter the PC mode and when no PC has been detected on the USB port the following warning message is displayed.

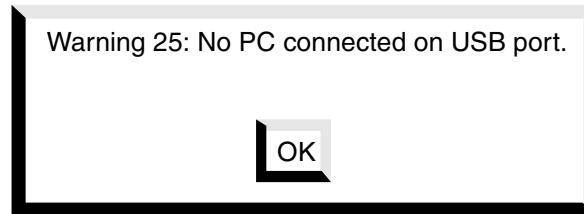

5.5 General Failures and Errors

A system general failure can be caused by hardware, software or transducer failure. All the errors described below are the most important errors which could happen during the system use. For some of them a restart of the system is involved.

Remark: the user should press on any key to acknowledge the message.

5.5.1 Error 0: Internal unexpected interrupt

Internal and unexpected CPU errors are displayed with a generic “Fatal Error” dialogue box.

This error is displayed when an unexpected interrupt raise or when an internal protected mode violation is detected. CPU registers and interrupt number are displayed in the dialogue box.

If this message is displayed, the user must send this information (video printout,...) to the service team. This will help the development team to correct the problem.

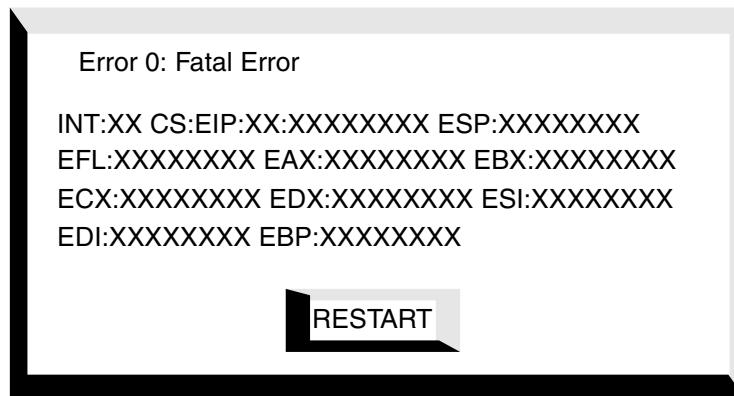

5.5.2 Error 1: Can not restore backed up configuration

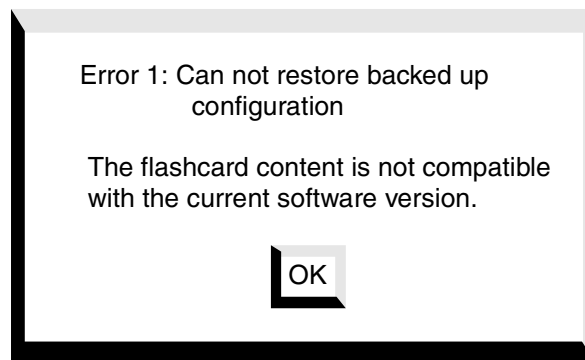

This message is displayed when the user tries to restore from a flashcard a backed up configuration that is not compatible with the current software version.

The configuration must be set manually by the user and saved again on the flashcard.

5.5.3 Error 2: Tracking problem - Fatal error

In case of a fatal error due to a transducer or a hardware problem, the following message is displayed and the system will be shut down after the user acknowledges the message.

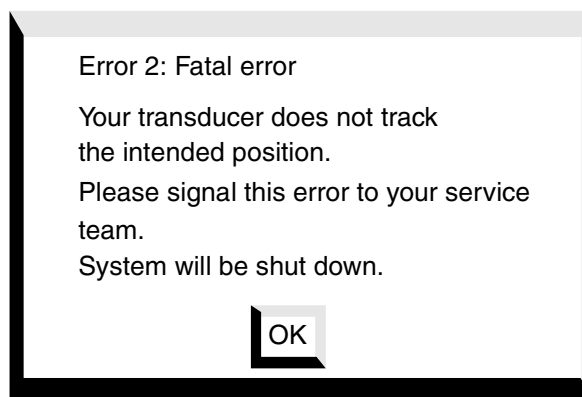

Different causes can produce this error:

- Endocavity probe temperature exceed 41° C: cool the transducer and restart the system
- Mechanical transducer broken or locked: e.g transducer motor problems
Call service to signal probe problem
- Problem on probe cable
- Problem on VLCUS board

5.5.4 Error 3: Memory allocation error - Fatal error

The memory allocation error message do not cause a lock of the system, but the current action (e.g add new annotation) can not be performed. If the user wants to use this function, he should restart the system.

If the problem persists, the user should inform the service team.

5.5.5 Error 4: Divide by 0 - Fatal error

The divide by 0 error message is displayed when a divide by 0 happens in the software (e.g corrupted stack, corrupted data by stack overflow, ...). When its happens the system is locked and the user should restart it by using the switch ON/OFF button.

If the problem persists, the user should inform the service team.

5.5.6 Error 5: Communication error

An error has occurred on the COM1 serial port. If the problem persists, the user should inform the service team.

5.5.7 Error 6: Flash card read error

The content of the flashcard can not been read, it may be broken. The user should change the flashcard. If the problem persists, the user should inform the service team.

5.5.8 Error 7: Flash card write error

The system can not write on the current plugged flashcard:

- the flashcard is write protected, the user should remove the write protection
- the flashcard is broken, the user should change the flashcard.

If the problem persists, the user should inform the service team.

5.5.9 Error 8: Invalid flash card type

The current plugged flashcard is not recognised by the system. The user should use a recommended flashcard. (see Chapter 6.3, “Accessories”, on page 6-5).

5.5.10 Error 9: Ob/Gyn restore error

When restoring users preferences from flashcard, the compliance of the restored data is checked. In case of incompatibility (inconsistent values restored) the following message is displayed:

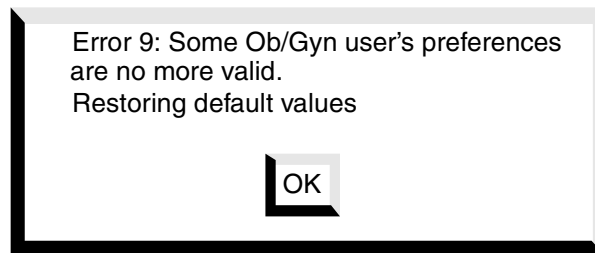

5.5.11 Error 10: Flashcard not correctly formatted

The SRAM format failed, or there is a problem with the current SRAM (archive). Re-format SRAM. If problem persists, SRAM is broken and should be changed

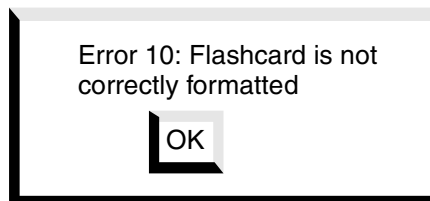

5.5.12 Error 11: Internal Communication - Fatal error

Internal communication error happens when the host does not receive message acknowledgement from one of the DSPs. After a time out, the “internal communication” error message is displayed. To acknowledge this message the user presses on any key and a message informs the user that the system will be powered off.

This error can happen when one of the DSPs has been reset due to software or hardware problems. If this problem persists, the user should call the service team.

To help the service team to find the cause of this problem, the user must press on the <H> key (when dialogue is displayed), and printout the current displayed screen. This screen contains information concerning the last sent messages.

5.5.13 Error 12: Cannot program TMPAVG

The TMPAVG (temporal average) is programmed at system start-up. If an error is detected (broken flash PROM, contact problems on it, etc., this error message can be displayed:

- when a new software is downloaded
- when the system is re-configured (with a new configuration key)

If this message is displayed, the user must inform the service team, its system may have a hardware problem.

5.5.14 Error 13: CFM Frame Filter LUT Error

At start-up, the frame filter LUT content is checked and updated if needed.

This error is displayed when the LUT can not be reprogrammed; this is usually due to a hardware problem.

If this message is displayed, the user must inform the service team.

5.5.15 Error 14: CFM Function LUT Error

At start-up, the function LUT content is checked and updated if needed.

This error is displayed when the LUT can not be reprogrammed; this is usually due to a hardware problem.

If this message is displayed, the user must inform the service team.

5.5.16 Error 15: CFM LUT programming time out error

This error is displayed when one of the LUT located on COL_DOP board can not be reprogrammed, usually due to a hardware problem.

If this message is displayed, the user must inform the service team

5.5.17 Error 16: Flashcard removed while printing

The following error is displayed if the flashcard is removed while the SIGMA is printing images on a printer.

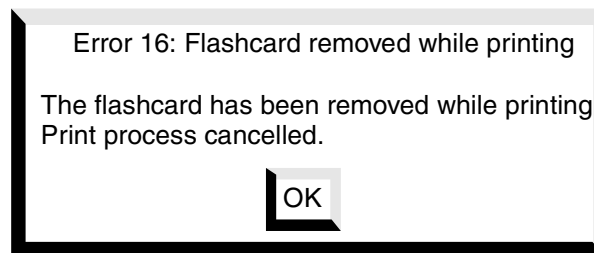

5.5.18 Error 17: Internal communication - Fatal error

This internal communication error is similar to the Error 11, but it happens when the host does not receive message acknowledgement from the processor located on the SUBSI board. In this case, the “internal communication” error message is displayed. To acknowledge this message the user presses on any key and a message informs the user that the system will be powered off. This error can happen when the SUBSI processor has been reset due to software or hardware problems. If this problem persists, the user should call the service team.

To help the service team to find the cause of this problem, the user must press on the <H> key (when dialogue is displayed), and printout the current displayed screen. This screen contains information concerning the last sent messages..

This page is intentionally left blank

6. OPTIONS AND ACCESSORIES

6.1 Options

SIGMA 110 Options:	
450 847	Cine Mode Option
483 281	ECG Option (including set of clamp electrodes)
483 311	Spectral Doppler Option
472 204	Bolero Cart Option
483 184	IR Remote Control Unit Option - ENG
483 176	IR Remote Control Unit Option - FRE
483 168	IR Remote Control Unit Option - GER
483 141	IR Remote Control Unit Option - ITA
483 133	IR Remote Control Unit Option - SPA
483 125	IR Remote Control Unit Option - CYR
481 068	Footswitch
482 765	Ext. Switch box for Master
485 926	Ext. Switch box for Bolero Cart
486 523B	EasyPrint™ Black & White
488 852	USB-Link™ option
487 260	VHS option
486531EN/486531GE/486531FR/486531SP	SonoWin Lite™ (English/German/French/Spanish version)
488798EN/488798GE/488798FR/488798SP	SonoWin Basic™ (English/German/French/Spanish version)
486 345	Flat LCD 15" screen repetition monitor + Holder Kit

Table 6-1: SIGMA 110 Options

SIGMA 330 Options:	
480 908	Colour Flow Mapping Option
483 281	ECG Option (including set of clamp electrodes)
481 068	Footswitch
482 765	Ext. Switch box for Master
485 926	Ext. Switch box for Bolero Cart
486 523	EasyPrint™ Color
488 852	USB-Link™ option
487 260	VHS option
486728EN/486728GE/486728FR/486728IT	3D-FetalView™ (English/German/French/Italian version)
486191EN/486191GE/486191FR/486191IT	3D-VascularView™ (English/German/French/Italian version)
486531EN/486531GE/486531FR/486531SP	SonoWin Lite™ (English/German/French/Spanish version)
488798EN/488798GE/488798FR/488798SP	SonoWin Basic™ (English/German/French/Spanish version)
486 345	Flat LCD 15" screen repetition monitor + Holder Kit

Table 6-2: SIGMA 330 Options

6.2 List of Probes

Reference No.	Probe Type
Convex Linear Probes	
471 933	3.5 MHz CV
484 385	3.5 MHz MC
485 497	6.5 MHz MC
Linear Probes	
484 474	5.0 MHz LV
474 460	7.5 MHz LV
483 656	7.5MHz LVS
Endocavitarian Probes	
469 017	6.5 MHz EV
469 025	6.5 MHz MR
479 101	6.5 MHz VMC
Mechanical Sector Probes	
469 041	3.5 MHz GP
469 068	5.0 MHz GP
469 076	7.5 MHz GP
469 033	14 MHz PV
Doppler Pencil Probes	
478 733	2.0 MHz PEN
468 517	4.0 MHz PEN
468525	8.0 MHz PEN
468 509	2.0 MHz TCD

Table 6-3: List of Probes

6.3 Accessories

Reference No.	Designation
100 250	250 ml bottle of ultrasound gel
469 122	Alkaline Battery 1.5 V for Remote control
477 729	Memory card (PCMCIA - SRAM 4 M)
480 266	Memory card (PCMCIA - SRAM 8 M)
485 055	Memory card (Flash 4 M) for backing up
481 068	FREEZE/PRINT Footswitch
503 126	Fuse 5 X 20 mm, T 8 A
528 129	Fuse 5 X 20 mm, T 6.3 A
717 150	Fuse 5 X 20 mm, T 4 A
524 204	Fuse 5 X 20 mm, T 2 A
411 353	Power cable EURO/D CEE 22
487 848	Power cable North American Hospital Grade
412 139	Power cable CEE22M/CEE22F (for integrated peripherals)
488 364	Power cable CEE22M/French female (for peripherals)
481 033	Remote control cable for Video Printer
862 169	Coaxial cable (75 Ohm, BNC/BNC, L = 2m)
486 434	VCR adapter for SVHS
481 076	Cable for S-VHS VCR
487 252	Cable for VHS VCR
485 659	Single S-VHS cable for color printer
479 764	Cable for Sony colour monitor or colour video printer
479 772	Mitsubishi colour monitor cable
485 861	CABEL colour monitor cable
479 802	Patient cable for ECG
430 706	Cable for equalization potential
487 163	USB Cable
485 519	Matrox/Orion Video Cable
487 155	VGA Video Cable
487 309	Keyboard Sticker "CTRL-ALT-ALTGR"
487 368	Keyboard Sticker "CAPS-DEL"
490 199	Cable D-Sub 25 M/F L = 1.5 m
489 859	Printer port isolator
488 542	S-Video isolator
490 024	S-Video distributor
488 550	BNC Video Isolation Amplifier
489 689	Adaptor S-VHS F/F mini DIN
487 732	Medical Grade isolating transformer (max. 750 VA)
DOC31001EN	Operator Manual SIGMA 110/330 - English
DOC31002EN	Service Manual SIGMA 110/330 - English
DOC31004EN	Operator Manual 3D-Vascular/Fetal View - English

Table 6-4: Accessories

Reference No.	Designation
462 489	Medical Ultrasound Safety Guide
870072	Printer cable Par. Bi-direct Subd 25M - Centronic 36M L= 1.8 m
488 216	RJ-45 Network isolator
482 951	Handle (for SIGMA 110 and SIGMA 330 Master)
462 519	Wall shelf
489 336	External FireWire 1.3 GB Magneto-Optical Disk Drive
489 506	Re-writable 1.3 GB Magneto-Optical Disk
488 763	Kit of 10 air filters
NA	HEWLETT PACKARD Deskjet 990Cxi (local purchasing)
NA	B & W Video Printer MITSUBISHI P91E (local purchasing)
NA	B & W Video Printer SONY UP890MD (local purchasing)
NA	Colour Video Printer MITSUBISHI CP700E (local purchasing)
NA	B & W VHS VCR (local purchasing)
NA	Additional B & W Monitor (local purchasing)

Table 6-4: Accessories

7. APPENDICES

Appendix A: Overview

A.1 Entering the Biometry

To enter the Biometry, press <REPORT> key. The image is automatically frozen if needed, and according to the current medical application (Radio, ObGyn,...) and current mode (2D, TM,...), a specific biometry screen is displayed.

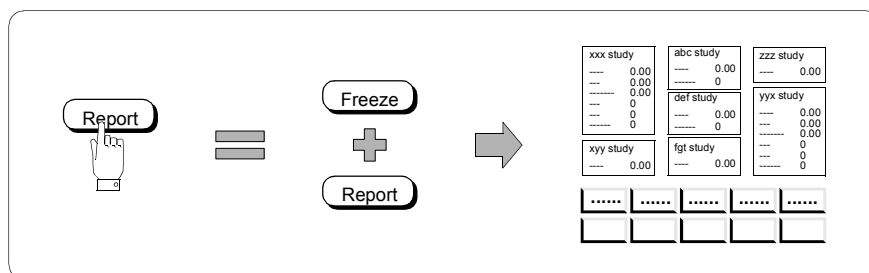

A.2 Exiting the Biometry

There are several means to exit the biometry:

- using the <REPORT> key, the user returns to the frozen image,

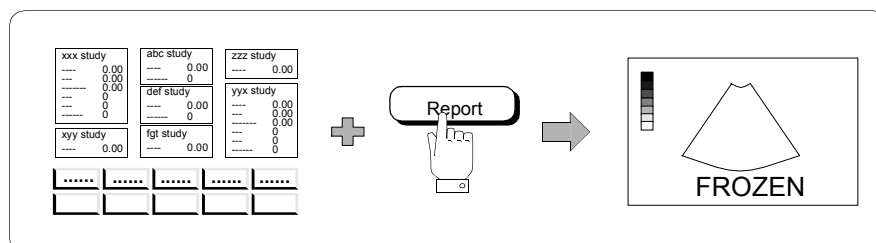

- using the <ESCAPE> key is the same as using the <REPORT> key
- using the <FREEZE> key, the user returns to a live image
- using the <MEASUREMENT> key, the user returns to a frozen image with the measurement menu active.
- using the <ANNOTATION> key, the user returns to a frozen image with the annotation menu active.
- using the <PROBE> key, the user returns to a frozen image with the probe menu active.
- using the <MAGNIFY> key, the user returns to a frozen magnified image when the current mode is the single 2D.

A.3 Make a Measurement from Report

The  represents the cursor used to select an object (measurement field or information field). This arrow can be moved with the trackball. When this arrow is over a valid object, the selected field is displayed in inverted video. To enter the selection, the user presses on the <ENTER> or <SET> key. When the selected field is a main field, the sigma switches to the frozen ultrasound

image and the measurement associated with the selection is automatically started. The user has now the possibility to:

- *finish the measurement*: the sigma switches then to the report screen and automatically updates the selected field and if needed, updates results fields and computed fields.
- *abort the measurement and return to the report screen*: the user aborts the measurement by pressing on the <ESCAPE> key.
- *abort the measurement and exit the biometry*: the user presses on the <FREEZE> key. The sigma returns then to the live mode.









A.4 Importing Measurements in Report

After having done a measurement, the user wants to insert it in the report; he selects the suitable report sheet and moves the trackball cursor on the fields of interest. When a relevant field is pointed, it highlights to indicate the insertion is possible. The user then presses on the CURSOR SET key to insert the last measurement. All the related results and computed fields are automatically updated if all data are available.

Note: to activate the import mode, the measurement menu must be displayed before entering the report.

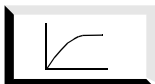
Appendix B: Report Menu

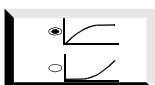
The meaning of the icons present in the different report menus are explained hereunder:

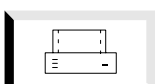
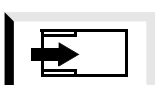
	Select a new medical application
	Go to next page
	Go to previous page
	Reset the selected field to zero
	View the selected ObGyn curve
	View printable report preview
	Start a new study; erase all the biometry fields
	Display setup screen for ObGyn
	Validate the user's choice on the displayed sl
	Exit current sheet Return to the previously displayed sheet
	Print the report on the printer
	Save the report on the flashcard

By pressing the  icon, the user changes the medical application. This modification concerns only the biometry study (the medical application of the probe does not change). After this operation a new biometry page (according to the current medical application) is proposed.

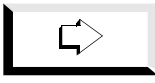
The  icon is only displayed when the current medical application study has more than one page. Pressing on this key displays the next page of the study.

Note : the report sheets are organized as a circular list :

first page +  = last page

last page +  = first page

The  icon is used in the print preview menu. Pressing on this key displays the previous page of the study. When the first page or the last page is displayed, the following rule is applied:

first page +  = last page

last page +  = first page

The  icon is used to delete a field. Pressing this key will delete the selected field (video inverted field)

By selecting the  icon, the user displays the printable report of his measurement.

The  icon is used to print the report on an external printer.

The  icon display the currently selected ob/gyn curve (i.e. the curve corresponding to the selected field in the master ob/gyn page or the selected curve from the Ob/gyn setup page).

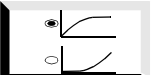
The  icon is used to change the working set of ob/gyn growth curves.

Before starting a new study with a new patient, the user must press on the  icon. Doing so, all the fields will be reset to zero.

The  is used to validate user's choice in setup and user setup pages. Doing so, all the user's changes are recorded in NoVRAM. If the user doesn't need to save his changes, he exists the displayed sheet using the <ESCAPE> key on keyboard.

The  is used to exit the print preview and return to the previous screen.

Appendix C: Patient Information

C.1 First Page

C.1.1 Description

The user enters this page when he presses on the <PATID> key while an ultrasound image is displayed.

14/02/01 08:30:31

LABORATORY INFORMATION Page 1

LAB. :
 PHYSICIAN :
 OPERATOR :

PATIENT INFORMATION

EXAM.N : FOLDER N : TAPE :

NAME :
 ADDRESS :
 PHONE :

HEIGHT : ... cm WEIGHT : ... kg BSA : m2
 BIRTHDATE :/..../.... SEX : ... HR : ... b/mn

OB/GYN STUDIES

LMP :/..../.... NWA : wk EBD:

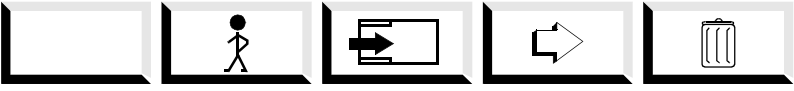

Note: the LMP, NWA and EBD information are always displayed on start page.

The  icon is used to reset the whole study.

For more details on report menu, see *Appendix B, "Report Menu", on page 7-5.*

C.1.1.1 Laboratory Information :

LAB. : Laboratory
 PHYSICIAN : Physician name
 OPERATOR : Operator name

C.1.1.2 Patient Information :

EXAM. N : Exam Number
 FOLDER N : Folder Number

TAPE : Tape
NAME : Patient Name
ADDRESS : Patient Address
PHONE : Phone Number
HEIGHT : Height in cm
WEIGHT : Weight in kg
BSA : Body Surface Area in m2
BIRTHDATE : Patient birth date
SEX : Patient sex
HR : Patient Heart Rate in beats per minute.
This field is unused in computations, it is only an information field.

The three following fields are useful for obstetrician:

LMP : Last Menstrual Period
NWA : Number of Weeks of Amenorrhea
EBD : Estimated Birth Date

C.1.2 Equation

- Body Surface Area in m2 (BSA) from Dubois and Dubois

$$BSA = 71,84 \cdot 10^{-4} \cdot W^{0,425} \cdot H^{0,725}$$

- W: weight in kg
H : height in cm

C.2 Second Page

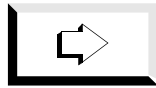

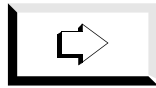
If the user presses on the  icon of first patient information page, the following sheet is displayed. If the user presses the same icon from the second patient information page, the first page is displayed again. For more details on report menu, see *Appendix B, "Report Menu"*, on page 7-5.

14/02/01 08:30:31

_____ PATIENT INFORMATION _____ Page 2 _____

REF. PHYS. :

.....

EXAMINATION REASONS :

.....

.....

.....

TREATMENT :

.....

.....

COMMENTS :

.....

.....

.....

.....

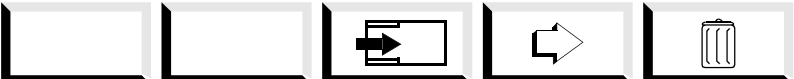

REF. PHYS : Referring physician
 EXAMINATION REASONS
 TREATMENT
 COMMENTS

This page is intentionally left blank

Appendix D: Cardiology Study

The cardiology report sheets are ordered according to the studied function (left ventricle, mitral valve, aortic valve, right ventricle ...). The following drawing locates the main studied functions:

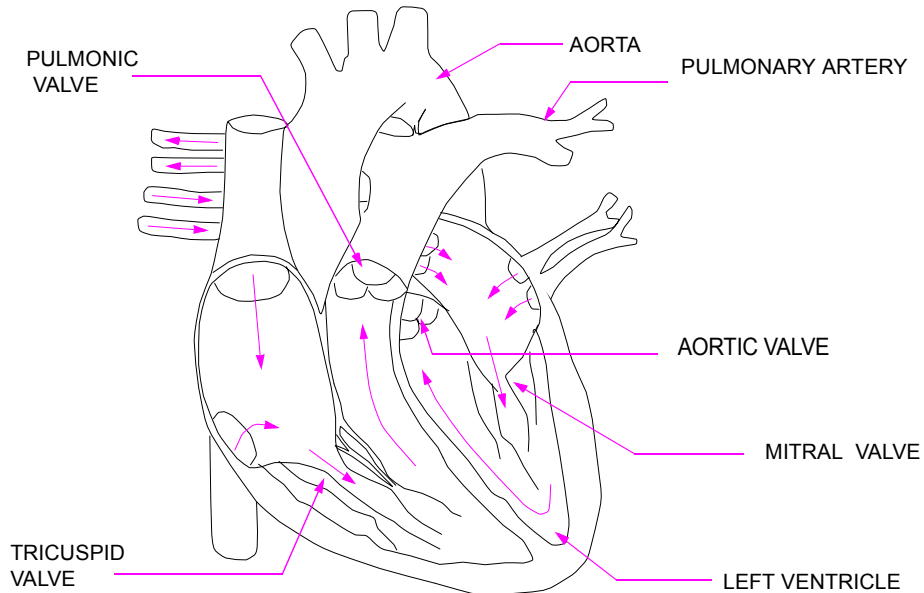

Hereunder, the functions and measurements available in the cardio study sheet are described.

D.1 Left Ventricle Study

D.1.1 Description

This sheet owns three parts as described here under:

		14/01/98 08:30:31
LAB.	:
OPER.	:
NAME	:
EXAM.N:	SEX:.....H:...cm W:...kg AGE: y BSA: m2 HR:...b/mn
CARDIOLOGY STUDIES : LEFT VENTRICLE		
LEFT VENTRICLE (TM)	->CO[l/mn]	LV SIMPSON (2D)
RVDd[cm] _____	->CI[l/mn/m2]	SAA1d[cm2] _____
IVSd[cm] _____	->H/R	SAA2d[cm2] _____
*LVDD[cm] _____		LALd[cm] _____
*PLVWd[cm] _____	LEFT VENTRICLE (2D)	SAA1s[cm2] _____
*IVSs[cm] _____	LALd[cm] _____	SAA2s[cm2] _____
*LVDS[cm] _____	LAAd[cm2] _____	LALs[cm] _____
*PLVWs[cm] _____	LALs[cm] _____	->VOLd[cm3] _____
LVET[s] _____	LAAs[cm2] _____	->VOLs[cm3] _____
->VOLd[cm3] _____	->VOLd[cm3] _____	->EF[%] _____
->VOLs[cm3] _____	->VOLs[cm3] _____	->SV[ml] _____
->SF[%] _____	->EF[%] _____	->SI[ml/m2] _____
->LVM[g] _____	->SV[ml] _____	->CO[l/mn] _____
->LVMI[g/m2] _____	->SI[ml/m2] _____	->CI[l/mn/m2] _____
->VCF[cm/s] _____	->CO[l/mn] _____	
->EF[%] _____	->CI[l/mn/m2] _____	HEART RATE
->SV[ml] _____		HR[b/mn] _____
->SI[ml/m2] _____		

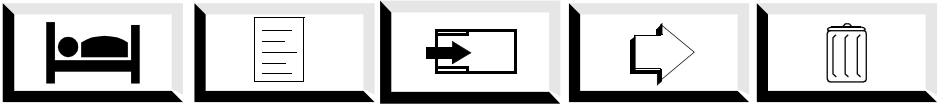

D.1.1.1 Left Ventricle Study

a) 2D measurements

- LALd : Long Axis Length at diastole in cm
- LAAd : Long Axis Area at diastole in cm²
- LALs : Long Axis Length at systole in cm
- LAAs : Long Axis Area at systole in cm²
- >VOLd : Diastolic Volume in cm³
- >VOLs : Systolic Volume in cm³
- >EF : Ejection Fraction in percent
- >SV : Stroke Volume in millilitres
- >SI : Stroke Index in millilitres
- >CO : Cardiac Output in litres per minute
- >CI : Cardiac Index in litres per minute per square meters

b) TM measurements

- RVDd : Right Ventricle Diameter at diastole in cm
- IVSd : Inter Ventricular Septal Thickness at diastole in cm

*LVDD	: Left Ventricle Diameter at diastole in cm
*PLVWd	: Posterior Left Ventricular Wall at diastole in cm
*IVSs	: Inter Ventricular Septal Thickness at systole in cm
*LVDs	: Left Ventricle Diameter at systole in cm
*PLVWs	: Posterior Left Ventricular Wall at systole in cm
LVET	: Left Ventricle Ejection Time in second
->VOLd	: Diastolic Volume (Teichholz formula) in cm ³
->VOLs	: Systolic Volume (Teichholz formula) in cm ³
->SF	: Shortening Fraction in percent
->LVM	: Left Ventricle Mass in grams
->LVMI	: Left Ventricle Mass Index in grams per square meters
->VCF	: Velocity of Circumferential Fibre Shortening in circumference per second
->EF	: Ejection Fraction in percent
->SV	: Stroke Volume in millilitres
->SI	: Stroke Volume Index in millilitres per square meters
->CO	: Cardiac Output in litres per minute
->CI	: Cardiac Output Index in litres per minute per square meter
->H/R	: Ratio Left Ventricular Wall (diastole) on Left Ventricle Radius (diastole)

D.1.1.2 Left Ventricle Study (Simpson)

SAA1d	: Short Axis Area 1 at Diastole in cm ²
SAA2d	: Short Axis Area 2 at Diastole in cm ²
LALd	: Long Axis Length at Diastole in cm
SAA1s	: Short Axis Area 1 at Systole in cm ²
SAA2s	: Short Axis Area 2 at Systole in cm ²
LALs	: Long Axis Length at Systole in cm
->VOLd	: Diastolic Volume in cm ³
->VOLs	: Systolic Volume in cm ³
->EF	: Ejection Fraction in percent
->CO	: Cardiac Output in litres per minute
->CI	: Cardiac Index in litres per minute per square meters
->SV	: Stroke Volume in millilitres
->SI	: Stroke Index in millilitres

D.1.1.3 Heart Rate (TM and SP Measurement)

HR	: Heart rate in beats per minutes measured on Left Ventricle. This field is used for the computation of the left ventricle study sheet
----	--

D.1.2 Equations

D.1.2.1 General Information

- Body Surface Area in m² (BSA) from Dubois and DuboisW: weight in kg

$$BSA = 71,84 \cdot 10^{-4} \cdot W^{0,425} \cdot H^{0,725}$$

W	: weight in kg
H	: height in cm

D.1.2.2 Left Ventricle Study

a) 2D study:

- End Diastolic Volume in cm³ (VOL_d)

$$VOL_d D \frac{8 \cdot LAA_d^2}{3 \cdot \pi \cdot LAL_d}$$

LAA_d : Long Axis Area at diastole in cm²
 LAL_d : Long Axis Length at diastole in cm

- End Systolic Volume in cm³ (VOL_s)

$$VOL_s D \frac{8 \cdot LAA_s^2}{3 \cdot \pi \cdot LAL_s}$$

LAA_s : Long Axis Area at systole in cm²
 LAL_s : Long Axis Length at systole in cm

- Ejection Fraction in percent (EF)

$$EF D \frac{VOL_d - VOL_s}{VOL_d} \cdot 100$$

VOL_d : End diastolic Volume in cm³
 VOL_s : End systolic Volume in cm³

- Stroke Volume in millilitres (SV)

$$SV D VOL_d - VOL_s$$

VOL_d : End diastolic Volume in cm³
 VOL_s : End systolic Volume in cm³

- Stroke Volume Index in square meters (SI)

$$SI D \frac{SV}{BSA}$$

SV : Stroke Volume in millilitres
 BSA : Body Surface Area in m²

- Cardiac Output in litres per minute (CO)

$$CO D \frac{SV \cdot HR}{1000}$$

SV : Stroke Volume in millilitres
 HR : Heart Rate in beats per minute

- Cardiac Output Index in litres per minute per square meters (CI)

$$CI \text{ D } \frac{CO}{BSA}$$

CO : Cardiac Output in litres per minute
 BSA : Body Surface Area in m²

b) TM study

- End Diastolic Volume in cm³ with Teichholz (VOLd)

$$VOLd \text{ D } \frac{7 \cdot LVDd^3}{2,40 LVDd}$$

LVDd : Left Ventricle Diameter (diastole) in cm

- End Systolic Volume in cm³ with Teichholz (VOLs)

$$VOLs \text{ D } \frac{7 \cdot LVDs^3}{2,40 LVDs}$$

LVDs : Left Ventricle Diameter (systole) in cm

- Shortening fraction in percentage (SF)

$$SF \text{ D } \frac{LVDd - LVDs}{LVDd} \cdot 100$$

LVDd : Left Ventricle Diameter (diastole) in cm
 LVDs : Left Ventricle Diameter (systole) in cm

- Left Ventricle Mass in grams (LVM)

$$LVM \text{ D } 1,04 \cdot [(IVSd - LVDd) \cdot PLVW]^3 \cdot LVDd^3 \cdot 13,6$$

IVSd : Inter Ventricular Septal thickness (diastole) in cm
 LVDd : Left Ventricle Diameter (diastole) in cm
 PLVWd : Left Ventricular posterior wall (diastole) in cm

- Left Ventricle Mass Index in grams per square meters (LVMI)

$$LVMI \text{ D } \frac{LVM}{BSA}$$

LVM : Myocardial Mass in grams
 BSA : Body Surface Area in m²

- Left Ventricle circumferential in circumference per second (VCF)

$$VCF D \frac{LVDd \square LVDs}{LVDd \cdot LVET}$$

LVDd : Left Ventricle Diameter (diastole) in cm
 LVDs : Left Ventricle Diameter (systole) in cm
 LVET : Left Ventricle Ejection Time in second

- Ejection Fraction in percent (EF)

$$EF D \frac{VOLd \square VOLS}{VOLd} \cdot 100$$

VOLd : End diastolic Volume in cm³ (Teichholz)
 VOLS : End systolic Volume in cm³ (Teichholz)

- Stroke Volume in millilitres (SV)

$$SV D VOLDs \square VOLSs$$

VOLD : End diastolic Volume in cm³ (Teichholz)
 VOLS : End systolic Volume in cm³ (Teichholz)

- Stroke Volume Index in millilitres per square meters (SI)

$$SI D \frac{SV}{BSA}$$

SV : Stroke Volume in millilitres
 BSA : Body Surface Area in m²

- Cardiac Output in litres per minute (CO)

$$CO D \frac{SV \cdot HR}{1000}$$

SV : Stroke Volume in cm³
 HR : Heart Rate in beats per minute

- Cardiac Output Index in litres per minute per square meters (CI)

$$CI D \frac{CO}{BSA}$$

CO : Cardiac Output in litres per minute
 BSA : Body Surface Area in m²

- Ratio Left Ventricular Wall at diastole on Left Ventricle Radius at diastole (H/R)

$$H/R D \frac{IVSDd \square PLVWd}{LVDd}$$

IVSDd : Inter Ventricular Septal Thickness at diastole
 PLVWd : Posterior Left Ventricular Wall at diastole
 LVDd : Left Ventricle Diameter at diastole

D.1.2.3 Left Ventricle Study (Simpson)

- End Diastolic Volume in cm³ (VOLd)

$$VOLd = D \left(SAA1d \left(\frac{2 \cdot SAA2d}{3} \right) \cdot \left(\frac{LALd}{2} \right) \right)$$

SAA1d : Short Axis Area 1 at diastole in cm²
 SAA2d : Short Axis Area 2 at diastole in cm²
 LALd : Long Axis Length at diastole in cm

- End Systolic Volume in cm³ (VOLs)

$$VOLs = D \left(SAA1s \left(\frac{2 \cdot SAA2s}{3} \right) \cdot \left(\frac{LALs}{2} \right) \right)$$

SAA1s : Short Axis Area 1 at systole in cm²
 SAA2s : Short Axis Area 2 at systole in cm²
 LALs : Long Axis Length at systole in cm

- Ejection Fraction in percent (EF)

$$EF = D \frac{VOLd - VOLs}{VOLd} \cdot 100$$

VOLd : End diastolic Volume in cm³
 VOLs : End systolic Volume in cm³

- Cardiac Output in litres per minute (CO)

$$CO = D \frac{SV \cdot HR}{1000}$$

SV : Stroke Volume in millilitres
 HR : Heart Rate in beats per minute

- Cardiac Output Index in litres per minute per square meters (CI)

$$CI = D \frac{CO}{BSA}$$

CO : Cardiac Output in litres per minute
 BSA : Body Surface Area in m²

- Stroke Volume in millilitres (SV)

$$SV = D VOLd - VOLs$$

VOLd : End diastolic Volume in cm³
 VOLs : End systolic Volume in cm³

- Stroke Volume Index in millilitres per square meters (SI)

$$SI = D \frac{SV}{BSA}$$

SV : Stroke Volume in millilitres
BSA : Body Surface Area in m²

D.2 Mitral Valve Study

D.2.1 Description

14/01/98 08:30:31

LAB. :
OPER. :
NAME :
EXAM.N:..... SEX:....H:...cm W:...kg AGE: y BSA: m² HR:...b/mn
___ CARDIOLOGY STUDIES : MITRAL VALVE _____

MV ANNULUS (2D)	MITRAL VALVE (SP)	MITRAL VALVE EOA
MVD[cm] _____	VTI [cm] _____	*CONTINUITY EQUATION
MVA[cm ²] _____	*PkV[m/s] _____	SAD[cm] _____
	*PkG[mmHg] _____	->SAA[cm ²] _____
	*MnG[mmHg] _____	VTI _{sa} [cm] _____
MITRAL VALVE (TM)	PkVE[m/s] _____	VTI _{mv} [cm] _____
EFsl [cm/s] _____	PkVA[m/s] _____	->EOA[cm ²] _____
ESd [cm] _____	IVRT[s] _____	
	->E/A _____	*PHT
HEART RATE	->SV[ml] _____	PHT[ms] _____
HR[b/mn] _____	->SI[ml/m ²] _____	*PkVE[m/s] _____
	->CO[l/mn] _____	->EOA [cm ²] _____
	->CI[l/mn/m ²] _____	

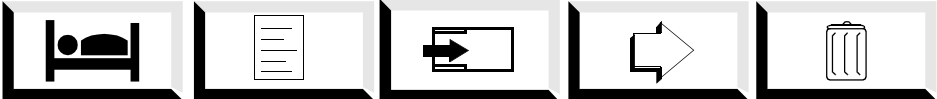

D.2.2 2D measurements

MVD : Mitral Valve Diameter in cm
MVA : Mitral Valve Area in cm²

a) TM measurements

EFsl : Slope between E- and F-waves in cm/s
ESd : Distance from E-wave to septum in cm

b) SP measurements

VTI : Velocity Time Integral in cm
*PkV : (VTI) Peak Velocity in m/s
*PkG : (VTI) Peak Gradient in mmHg

- *MnG : (VTI) Mean Gradient in mmHg
- PkVE : Peak Velocity for the E-wave in m/s
- PKVA : Peak Velocity for the A-wave in m/s
- IVRT : IsoVolumetric Relaxation Time in second
- >E/A : Ratio Peak Velocity E-wave on Peak Velocity A-wave (PkVE/PkVA)
- >SV : Stroke Volume in millilitres
- >SI : Stroke Volume Index in millilitres per square meters
- >CO : Cardiac Output in litres per minute
- >CI : Cardiac Output Index in litres per minute per square meters

c) Heart rate (TM or SP measurement)

- HR : Patient heart rate in beats per minutes on mitral valve.
This field is used for the computation of the mitral valve study sheet

d) Mitral Valve Effective Opening Area

- Continuity Equation

- SAD : Sub Aortic Diameter in cm
- >SAA : Area in cm² computed from DiamAOV
- VTIaov : Sub Aortic Velocity Time Integral in cm
- VTImv : Velocity Time Integral at Mitral Valve in cm
- >EOA : Mitral Valve EOA in cm² computed from VTIaov and VTImiv

- Pressure Half Time

- PHT : Pressure Half Time in millisecond
- *PkVE : Peak Velocity for E-wave in m/s
- >EOA : Valve Area in cm² computed from Pressure Half Time

D.2.3 Equations

a) SP study

- Velocity Time Integral (VTI) in cm

$$VTI = \sum V_i \cdot \Delta t$$

$$V D \frac{D_f \cdot C}{2 \cdot f_0 \cdot \cos \alpha}$$

- V_i : Velocity (in m/s) during each Dt (in s) of measured spectral area
- D_f : Doppler frequency in Herz
- C : Sound velocity (1540 m/s)
- f₀ : Ultrasound frequency in Herz
- α : Angle between the ultrasound beam and blood velocity

- Pressure Time Integral in seconds per mmHg (PTI)

$$PTI = \sum P_i \cdot \Delta t$$

P_i : Pressure (in mmHg) during each Δt (in s) of the velocity spectrum
 Computed from simplified Bernouilli equation.
 v : Velocity in m/s

- Mean Gradient in mmHg (MnG)

$$MnG = \frac{PTI}{Time}$$

PTI : Pressure Time Integral
 Time : Duration flow in seconds

- Pressure Half Time in millisecond (PHT)

$$PHT = \frac{PV \cdot (1 \pm \sqrt{2})}{S}$$

PV : Peak Velocity in metres per millisecond
 S : Slope in metres per square seconds

- Mitral Valve Area in cm² (EOA) computed from PHT

$$EOA = \frac{220}{PHT}$$

PHT : Pressure Half Time in milliseconds

- Cardiac Output in litres per minute (CO)

$$CO = \frac{SV \cdot HR}{1000}$$

SV : Stroke Volume in millilitres
 HR : Heart Rate in beats per minute

- Cardiac Output Index in litres per minute per square meters (CI)

$$CI = \frac{CO}{BSA}$$

CO : Cardiac Output in litres per minute
 BSA : Body Surface Area in square meters

- Stroke Volume in millilitres(SV)

$$SV = MVA \cdot VTI$$

$$MVA = \frac{\pi \cdot MVD^2}{4}$$

VTI : Velocity Time Integral in cm
 MVD : Mitral Valve Diameter in cm

- Stroke Index Volume in millilitres per square metres (SI)

$$SI = \frac{SV}{BSA}$$

SV : Stroke Volume in millilitres
 BSA : Body Surface Area in square meters

b) Continuity equation

- Area in cm² computed from SAD (SAA)

$$SAA = \frac{\pi \cdot SAD^2}{4}$$

SAD : Sub Aortic Diameter in cm

- Mitral Valve EOA in cm² computed from velocities time integral (EAO)

$$EAO = \frac{SAA \cdot VTIsa}{VTImv}$$

VTIsa : Sub Aortic Velocity Time Integral in cm
 VTImv : Mitral Valve Velocity Time Integral in cm

D.3 Aortic Valve Study

D.3.1 Description

14/01/98 08:30:31

LAB. :
 OPER. :
 NAME :
 EXAM.N:..... SEX:....H:...cm W:...kg AGE: y BSA: m2 HR:... b/mn

 CARDIOLOGY STUDIES : AORTIC VALVE _____

AORTIC VALVE (2D)	AORTIC VALVE (TM)	LVOT (SP)
AVD[cm] _____	AoD[cm] _____	VTI[cm] _____
AVA[cm ²] _____	LAD[cm] _____	*PkV[m/s] _____
AORTIC VALVE (SP)	AVO[cm] _____	*PkG[mmHg] _____
VTI[cm] _____	LVET[s] _____	*MnG[mmHg] _____
*PkV[m/s] _____	LVPEP[s] _____	->SV[ml] _____
*PkG[mmHg] _____	->LAD/AoD _____	->SI[ml/m ²] _____
*MnG[mmHg] _____	->LVPEP/LVET _____	->CO[l/mn] _____
PHT[ms] _____		->CI[l/mn/m ²] _____
LVPEP[s] _____	HEART RATE	AORTIC VALVE EOA
->SV[ml] _____	HR[b/mn] _____	LVOTD[cm] _____
->SI[ml/m ²] _____		*LVOTA[cm ²] _____
->CO[l/mn] _____	LVOT (2D)	VTI _{lvot} [cm] _____
->CI[l/mn/m ²] _____	LVOTD[cm] _____	VTI _{ao} [cm] _____
DESCENDING AORTA(SP)	LVOTA[cm ²] _____	->EOA[cm ²] _____
VTI _s [cm] _____		V _{lvot} [m/s] _____
VTI _d [cm] _____		V _{ao} [m/s] _____
->VTI _d /VTI _s _____		->EOA[cm ²] _____

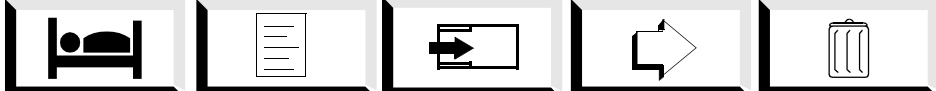

D.3.2 Aortic Valve

a) 2D study

AVA : Aortic Valve Area in cm²
 AVD : Aortic Valve Diameter in cm

b) SP study

VTI : Velocity Time Integral in cm
 *PkV : (VTI) Peak Velocity in m/s
 *PkG : (VTI) Peak Gradient in mmHg
 *MnG : (VTI) Mean Gradient in mmHg
 PHT : Pressure Half Time in millisecond
 LVPEP : Left Ventricle Pre Ejection Period in second
 ->SV : Stroke Volume in millilitres
 ->SI : Stroke Volume Index in millilitres per square meters
 ->CO : Cardiac Output in litres per minute
 ->CI : Cardiac Output Index in litres per minute per square meters

c) *TM study*

AoD : End diastolic Aortic Root diameter in cm
 LAD : Left Atrial end systolic diameter in cm
 AVO : Aortic Valve Opening in cm
 LVET : Left Ventricle Ejection Time in second
 LVPEP : Left Ventricle Pre-Ejection Period in second
 ->LAD/AoD : Ratio Left Atrial, Aortic Root Diameter
 ->LVPEP/LVET: Ratio Pre Ejection Period, Ejection Time

d) *Effective Opening Area Aortic Valve*

LVOTD : Left Ventricle Output Trunk Diameter in cm
 *LVOTA : Area in cm² computed from Divot
 Vlvot : Velocity at Left Ventricle Output Trunk in meters per second
 Vao : Velocity at Aortic Valve in meters per second
 VTllvot : Velocity Time Integral at Left Ventricle Output Trunk in cm
 VTI : Velocity Time Integral at Aortic Valve in cm
 ->EOA : Effective Opening Area of the Aortic Valve in cm². This area can be computed from VTllvot and VTlao, or from Vao and Vlvot.

D.3.2.1 *Left Ventricle Output Trunk*

a) *2D study*

LVOTD : LVOT Diameter in cm
 LVOTA : LVOT Area in cm²

b) *SP study*

VTI : Velocity Time Integral in cm
 *PkV : Peak Velocity in m/s
 *PkG : Peak Gradient in mmHg
 *MnG : Mean Gradient in mmHg
 ->SV : Stroke Volume in millilitres
 ->SI : Stroke Volume Index in millilitres per square meters
 ->CO : Cardiac Output in litres per minute
 ->CI : Cardiac Output Index in litres per minute per square meters

D.3.2.2 *Descending Aorta (SP Measurement)*

VTIs : Velocity Time Integral at Systole in cm
 VTId : Velocity Time Integral at Diastole in cm
 VTId/VTIs : Ratio VTI Diastole, VTI Systole

D.3.2.3 *Heart Rate (TM or SP Measurement)*

HR : Heart Rate in beat per minute on aortic valve
 This field is used for the computation of the aortic valve study sheet

D.3.3 Equations

a) SP study

- Velocity Time Integral (VTI) in cm

$$VTI = \sum V_i \cdot \Delta t$$

$$V D \frac{D_f \cdot C}{2 \cdot f_0 \cdot \cos \alpha}$$

V_i	: Velocity (in m/s) during each Δt (in s) of measured spectral area
D_f	: Doppler frequency in Herz
C	: Sound velocity (1540 m/s)
f_0	: Ultrasound frequency in Herz
α	: Angle between the ultrasound beam and blood velocity

- Pressure Time Integral in seconds per mmHg (PTI)

$$PTI = \sum P_i \cdot \Delta t$$

$$P D 4v^2$$

P_i	: Pressure (in mmHg) during each Δt (in s) of the velocity spectrum Computed from simplified Bernouilli equation
v	: Velocity in m/s

- Mean Gradient in mmHg (MnG)

$$MnG D \frac{PTI}{Time}$$

PTI	: Pressure Time Integral
Time	: Duration flow in seconds

- Pressure Half Time in millisecond (PHT)

$$PHT D \frac{PV \cdot (1 \square 0,707)}{S}$$

PV	: Peak Velocity in metres per millisecond
S	: Slope in metres per square seconds

- Cardiac Output in litres per minute (CO)

$$CO D \frac{SV \cdot HR}{1000}$$

SV	: Stroke Volume in millilitres
HR	: Heart Rate in beats per minute

- Cardiac Output Index in litres per minute (CI)

$$CI = \frac{CO}{BSA}$$

CO : Cardiac Output in litres per minute
 BSA : Body Surface Area in square meters

- Stroke Volume in millimetres (SV)

$$SV = area_{2D} \cdot VTI$$

$$area_{2D} = \frac{\pi \cdot D^2}{4}$$

VTI : Velocity Time Integral
 D : Diameter of vessel in centimetres

- Stroke Index Volume in millilitres per square metres (SI)

$$SI = \frac{SV}{BSA}$$

SV : Stroke Volume in millilitres
 BSA : Body Surface Area in square meters

b) Continuity equation

- Area in cm² computed from LVOTD (LVOTA)

$$LVOTA = \frac{\pi \cdot LVOTD^2}{4}$$

LVOTD : Left Ventricle Output Trunk Diameter in cm

- Effective Opening Area at Aortic Valve in cm² computed from velocities (EOA)

$$EOA = \frac{LVOTA \cdot V_{lvot}}{V_{ao}}$$

V_{lvot} : Velocity at Left Ventricle Output Trunk in m/s
 V_{ao} : Velocity at Aortic Valve in m/s

- EOA at Aortic Valve in cm² computed from velocities time integral (EOA)

$$EOA = \frac{LVOTA \cdot VTI_{lvot}}{VTI_{ao}}$$

VTI_{lvot} : Velocity Time Integral at Left Ventricle Output Trunk in cm
 VTI_{ao} : Velocity Time Integral at Aortic Valve in cm

D.4 Right Ventricle Study

D.4.1 Description

14/01/98 08:30:31

LAB. :
 OPER. :
 NAME :
 EXAM.N:..... SEX:....H:...cm W:...kg AGE: y BSA: m2 HR:... b/mn

 CARDIOLOGY STUDIES: RIGHT VENTRICLE _____

PULMONIC VALVE (2D)	TRICUSPID VALVE (TM)	CONTINUITY EQUATION
PAD[cm] _____	DEs1[cm/s] _____	Diam1[cm] _____
		*AREA1[cm2] _____
PULMONIC VALVE (SP)	TRICUSPID VALVE (SP)	VTI1[cm] _____
VTI[cm] _____	TRV[m/s] _____	VTI2[cm] _____
*PkV[m/s]	->RVRAGr[mmHg]	->Area2[cm2] _____
*PkG[mmHg]		VEL1[m/s] _____
*MnG[mmHg]		VEL2[m/s] _____
RVPEP[s] _____	HEART RATE	->AREA2[cm2] _____
->SV[ml]	HR[b/mn] _____	
->SI[ml/m2]		
->CO[l/mn]		
->CI[l/mn/m2]		

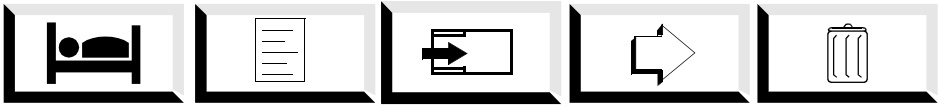

D.4.2 Pulmonic Valve

a) 2D measurements

PAD : Pulmonary Artery Diameter in cm

b) SP measurements

VTI : Velocity Time Integral in cm
 *PkV : (VTI) Peak Velocity in m/s
 *PkG : (VTI) Peak Gradient in mmHg
 *MnG : (VTI) Mean Gradient in mmHg
 PHT : Pressure Half Time in millisecond
 RVPEP : Right Ventricle Pre Ejection Period in second
 ->SV : Stroke Volume in millilitres
 ->SI : Stroke Volume Index in millilitres per square meters
 ->CO : Cardiac Output in litres per minute
 ->CI : Cardiac Output Index in litres per minute per square meters

D.4.2.1 Tricuspid Valve

a) TM measurements

DEs1 : Slope between D- and E-wave in cm/s

b) SP measurements

TRV : Tricuspid Regurgitation Velocity in m/s
 ->RVRAGr : Right Ventricular Right Atrial Gradient mmHg

D.4.2.2 Continuity Equation (Free Measurement)

a) 2D measurements

Diam : Diameter in cm
 ->AREA1 : Area 1 in cm² computed from Diam1

b) SP measurements

VTI1 : Velocity Time Integral 1 in cm
 VTI2 : Velocity Time Integral 2 in cm
 ->AREA2 : Area 2 in cm² computed from VTI1 and VTI2
 Vel1 : Velocity 1 in meters per second
 Vel2 : Velocity 2 in meters per second
 ->AREA2 : Area 2 in cm² computed from VEL1 and VEL2

D.4.2.3 Heart Rate (SP or TM Measurement)

HR : Heart rate in beats per minutes on right ventricle.
 This field is used for the computation of the right ventricle study sheet

D.4.3 Equations

D.4.3.1 Pulmonic Valve

- Velocity Time Integral (VTI) in cm

$$VTI = \sum V_i \cdot \Delta t$$

$$V D \frac{D_f \cdot C}{2 \cdot f_0 \cdot \cos \alpha}$$

V_i : Velocity (in m/s) during each Δt (in s) of measured spectral area
 D_f : Doppler frequency in Herz
 C : Sound velocity (1540 m/s)
 f_0 : Ultrasound frequency in Herz
 α : Angle between the ultrasound beam and blood velocity

- Pressure Time Integral in seconds per mmHg (PTI)

$$PTI = \sum P_i \cdot \Delta t$$

$$P D 4 v^2$$

P_i : Pressure (in mmHg) during each Δt (in s) of the velocity spectrum

v Computed from simplified Bernoulli equation
: Velocity in m/s

- Mean Gradient in mmHg (MnG)

$$MnG \propto \frac{PTI}{Time}$$

PTI : Pressure Time Integral
Time : Duration flow in seconds

- Pressure Half Time in millisecond (PHT)

$$PHT \propto \frac{PV \cdot (1 \div 0,707)}{S}$$

PV : Peak Velocity in metres per millisecond
S : Slope in metres per square seconds

- Cardiac Output in litres per minute (CO)

$$CO \propto \frac{SV \cdot HR}{1000}$$

SV : Stroke Volume in millilitres
HR : Heart Rate in beats per minute

- Cardiac Output Index in litres per minute (CI)

$$CI \propto \frac{CO}{BSA}$$

CO : Cardiac Output in litres per minute
BSA : Body Surface Area in square meters

- Stroke Volume in millimetres (SV)

$$SV \propto area_{2D} \cdot VTI$$

$$area_{2D} \propto \frac{\pi \cdot D^2}{4}$$

VTI : Velocity Time Integral
D : Diameter of vessel in centimetres

- Stroke Index Volume in millilitres per square metres (SI)

$$SI \propto \frac{SV}{BSA}$$

SV : Stroke Volume in millilitres
BSA : Body Surface Area in square meters

D.4.3.2 Tricuspid Valve

- Right Ventricular Right Auricular Gradient in mmHg (RVRAGr)

$$RVRAGR \approx 4 \cdot TRV^2$$

TRV : Tricuspid Regurgitation Velocity in meters per second

D.4.3.3 Continuity Equation

- Area in cm² computed from 2D diameter (AREA1)

$$AREA1 \approx \frac{\pi \cdot Diam^2}{4}$$

Diam :Diameter in cm

- Area in cm² computed from velocities (AREA2)

$$AREA2 \approx \frac{AREA1 \cdot Vel1}{Vel2}$$

Vel1 : Velocity 1 in m/s
 Vel2 : Velocity 2 in m/s

- Area in cm² computed from velocities time integral (AREA2)

$$AREA2 \approx \frac{AREA1 \cdot VTI1}{VTI2}$$

VTI1 : Velocity Time Integral 1 in cm
 VTI2 : Velocity Time Integral 2 in cm

This page is intentionally left blank

Appendix E: Vascular Study

E.1 Description

14/01/98 08:30:31

LAB. :
 OPER. :
 NAME :
 EXAM.N:..... SEX:....H:000cm W:000.0kg AGE: 0y BSA: 0m2 HR:000b/mn

VASCULAR STUDIES

STENOSIS PERCENTAGE	SPEC. BROA. INDEX	CONTINUITY EQUATION
Vel1[m/s] _____	VTI [cm] _____	Diam1 [cm] _____
Vel2[m/s] _____	*TAMX [m/s] _____	ÆAREA1 [cm2] _____
ÆS [%] _____	*PkV [m/s] _____	Vel1 [m/s] _____
STENOSIS INDEX	CARDIAC OUTPUT	RES.IND. PUL.IND.
VTI [cm] _____	VTI [cm] _____	PI _____
*TAMX [m/s] _____	Diam [cm] _____	*TAMX [m/s] _____
*PkV [m/s] _____	ÆSV [ml] _____	*VELs [m/s] _____
ÆSTI _____	ÆSI [ml/m2] _____	*VELd [m/s] _____
VOLUME	HEART RATE	ÆVELs/VELd _____
d1 [cm] _____	HR [b/mn] _____	RI _____
d2 [cm] _____	FREQUENCY	*VELs [m/s] _____
d3 [cm] _____	Freq [kHz] _____	*VELd [m/s] _____
ÆV [cm3] _____		ÆVELs/VELd _____
VOLUME FLOW		
MVI [cm] _____		
*TAV [m/s] _____		
Diam [cm] _____		
ÆBF [l/mn] _____		

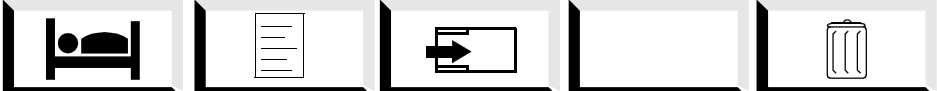

E.2 Stenosis Percentage

Vel1 : Velocity on the stenosis in m/s
 Vel2 : Velocity before or after the stenosis in m/s
 ÆS : Stenosis in percentage

a) Stenosis Index

VTI : Velocity Time Integral in cm
 *TAMX : Time Average Maximum Velocity in m/s
 *PkV : Peak Velocity in m/s
 ÆSTI : Stenosis Index

E.2.1 Volume

d1 : Distance 1 in cm
 d2 : Distance 2 in cm
 d3 : Distance 3 in cm

ÆV : Vascular Volume in cm³

E.2.2 Volume Flow

MVI : Mean Velocity Integral in cm
*TAV : Time Average Velocity in m/s
Diam : Diameter of the vessel in cm
ÆBF : Blood Flow in l/mn

E.2.3 Spectral Broadening Index

VTI : Velocity Time Integral in cm
*TAMX : Time Average Maximum Velocity in m/s (Mean Velocity)
*PKV : Peak Velocity in m/s
MVI : Mean Velocity Integral in cm
*TAV : Time Average Velocity in m/s
ÆSBI : Spectral Broadening Index

E.2.4 Cardiac Output

VTI : Velocity Time Integral in cm
Diam : Diameter of the vessel in cm
ÆSV : Stroke Volume millilitres
ÆSI : Stroke Volume Index in millilitres per square meters
ÆCO : Cardiac Output litres per minute
ÆCI : Cardiac Output Index in litres per minute per square meters

E.2.5 Frequency

Freq : Doppler frequency shift in kHz

E.2.6 Heart Rate (SP or TM measurement)

HR : Measured Heart rate in beats per minutes. This field is used for the computation of the aortic valve study sheet

E.2.7 Continuity Equations

Diam1 : Diameter 1 in cm
*AREA1 : Area 1 in cm²
Vel1 : Velocity 1 in m/s
Vel2 : Velocity 2 in m/s
ÆAREA2 : Area 2 with the Velocity in cm²
VTI1 : Velocity Time Integral 1 in cm
VTI2 : Velocity Time Integral 2 in cm
ÆAREA2 : Area 2 with the Velocity Time Integral in cm²

E.2.8 Resistance Index, Pulsatility Index

RI : Resistance Index
PI : Pulsatility Index
*Vels : Velocity at Systole in m/s
*Veld : Velocity at Diastole in m/s
*TAMX : Mean Velocity in m/s

$\frac{V_{systole}}{V_{diastole}}$: Ratio Velocity Systole/Diastole

The resistance index can be either deduced from the PI calculation or computed separately. Since it can be computed separately, some parameters are duplicated.

E.3 Equations

E.3.1 Velocity Time Integral

- Velocity Time Integral (VTI) in cm

$$VTI = \sum V_i \cdot \Delta t$$

$$V D \frac{D_f \cdot C}{2 \cdot f_0 \cdot \cos \alpha}$$

V_i	: Velocity (in m/s) during each Δt (in s) of measured spectral area
D_f	: Doppler frequency in Herz
C	: Sound velocity (1540 m/s)
f_0	: Ultrasound frequency in Herz
α	: Angle between the ultrasound beam and blood velocity

E.3.2 Stenosis Percentage

- Stenosis percentage (S)

$$S D \left(1 - \frac{Vel2}{Vel1} \right) \cdot 100$$

$Vel1$: Velocity on the stenosis in m/s
$Vel2$: Velocity before or after the stenosis in m/s

E.3.3 Stenosis Index

- Time Average Maximum Velocity in metres per second (TAMX)

$$TAMX D \frac{VTI}{Time}$$

VTI	: Velocity Time Integral
$Time$: Duration flow in seconds

- Stenosis Index (STI)

$$STI D \left(1 - \frac{TAMX}{PkV} \right) \cdot 0,9$$

$TAMX$: Time Average Maximum Velocity in m/s
PkV	: Peak Velocity at systole in m/s

E.3.4 Ellipsoid Volume

- Ellipsoid volume in cm³ (V)

$$V = D^{4/3} \cdot \pi \cdot \frac{D1 \cdot D2 \cdot D3}{8}$$

D1 : Distance 1
 D2 : Distance 2
 D3 : Distance 3

E.3.5 Spectral Broadening Index

- Time Average Velocity in metres per second (TAV)

$$TAV = D \frac{MVI}{Time}$$

MVI : Mean Velocity Time Integral
 Time : Duration flow in seconds

- Time Average Maximum Velocity in metres per second (TAMX)

$$TAMX = D \frac{VTI}{Time}$$

VTI : Velocity Time Integral
 Time : Flow duration flow in seconds

- Spectral broadening Index (SBI)

$$SBI = D \left(1 - \frac{TAV}{TAMX} \right) \cdot 100$$

TAV : Time Average Velocity in m/s
 TAMX : Time Average Maximum Velocity in m/s

E.3.6 Cardiac Output

- Stroke Volume in millilitres (SV)

$$SV = D \cdot area_{2D} \cdot VTI$$

$$area_{2D} = D \frac{\pi \cdot D^2}{4}$$

VTI : Velocity time integral
 D : Diameter of vessel in centimetres

- Stroke Index Volume in millilitres per square metres (SI)

$$SI = D \frac{SV}{BSA}$$

SV : Stroke Volume in millilitres
 BSA : Body Surface Area in square meters

- Cardiac Output in litres per minute (CO)

$$CO \text{ D } \frac{SV \cdot HR}{1000}$$

SV : Stroke Volume in millilitres
 HR : Heart Rate in beats per minute

- Cardiac Index in litres per minute per square metres (CI)

$$CI \text{ D } \frac{CO}{BSA}$$

CO : Cardiac Output in litres per minute
 BSA : Body Surface Area in square meters

E.3.7 Volume Flow

- Time Average Velocity (TAV)

$$*TAV \text{ D } \frac{MVI}{Time}$$

*TAV : Time Average Velocity in cm/s
 MVI : Mean Velocity Integral in cm (corrected according to the angle)
 Time : Duration flow in seconds

- Blood Flow using VMean (BF)

$$BF \text{ D } \frac{TAV \cdot 60 \cdot \frac{\pi}{4} \cdot D^2}{1000}$$

BF : Blood Flow in l/min.
 TAV : Time Average Velocity in cm/s
 D : Diameter of the vessel in cm

E.3.8 Continuity Equation

- Area in cm² computed from 2D diameter (AREA1)

$$AREA1 \text{ D } \frac{\pi \cdot Diam^2}{4}$$

Diam :Diameter in cm

- Area in cm² computed from velocities (AREA2)

$$AREA2 \text{ D } \frac{AREA1 \cdot Vel1}{Vel2}$$

Vel1 : Velocity 1 in m/s
 Vel2 : Velocity 2 in m/s

- Area in cm² computed from velocities time integral (AREA2)

$$AREA2 \propto \frac{AREA1 \cdot VT1}{VT2}$$

VT1 : Velocity Time Integral 1 in cm
 VT2 : Velocity Time Integral 2 in cm

E.3.9 Resistance Index, Pulsatility Index

- Time Average Maximum Velocity in metres per second (TAMX)

$$TAMX \propto \frac{VTI}{Time}$$

VTI : Velocity Time Integral
 Time : Duration flow in seconds

- Resistance Index from Pourcelot (RI)

$$RI \propto \frac{Vels - Veld}{Vels}$$

Vels : Velocity at systole m/s
 Veld : Velocity at diastole in m/s

- Pulsatility Index

$$PI \propto \frac{Vels - Veld}{TAMX}$$

Vels : Velocity at systole m/s
 Veld : Velocity at diastole in m/s
 TAMX : Time Average Maximum Velocity in m/s

Appendix F: Ob/Gyn Studies

F.1 2D Sheet

F.1.1 Description

14/03/01 08:30:31

LAB. :
 OPER. :
 NAME :
 EXAM.N:

___ OB/GYN STUDIES _____

LMP :/..../..... NWA : wk EBD :

	Meas (cm)	AGE	+/-	
CRL :	_____			ÆCI[%]
GES :	_____			ÆHC/AC[%]
ChD :	_____			ÆFML/AC[%]
BPD :	_____			ÆFML/BPD[%]
BOD :	_____			
OFD :	_____			WEIGHT[g]
HC :	_____			+/-[g]
TAD :	_____			AUA
APD :	_____			AEBD
AC :	_____			
THD :	_____			
FML :	_____			
HuL :	_____			
*AC :				
*HC :				

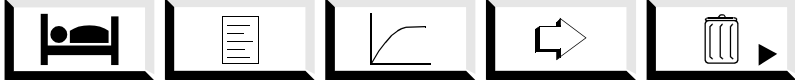

Second function keys page

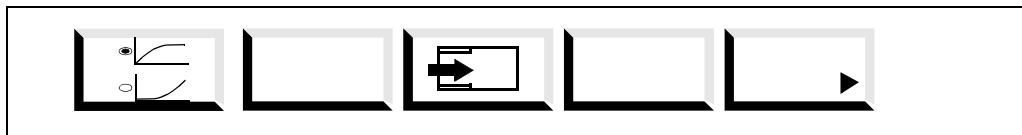

LMP : Last Menstrual Period
 EBD : Estimated Birth Date
 NWA : Number of Weeks of Amenorrhea

CRL : Crow Rump Length in cm
 GES : Gestational Sac in cm
 ChD : Chorion Diameter in cm
 BPD : Biparietal Diameter in cm
 BOD : Binocular Distance in cm
 OFD : Occipital Frontal Diameter in cm

HC	: Head Circumference in cm
TAD	: Transabdominal Diameter in cm
APD	: Anterior Posterior Diameter in cm
AC	: Abdominal Circumference in cm
THD	: Thoracic Diameter in cm
FML	: Femur Length in cm
HuL	: Humerus Length in cm
*AC	: Abdominal Circumference Calculated in cm
*HC	: Head Circumference Calculated in cm
ÆCI	: Cephalic Index (BPD/OFD) in percentage
ÆHC/AC	: Head Circumference / Abdominal Circumference
ÆFML/AC	: Femur Length / Abdominal Circumference
ÆFML/BPD	: Femur Length / Biparietal Diameter
WEIGHT	: Foetal Weight in kg
+/-	: Uncertainty in kg
AUA	: Average Ultrasound Age in week
AEBD	: Average Estimated Birth Date

F.1.2 Equations

- **Estimated Foetal Age (Age) and uncertainty(+/-)**

For each kind of measurement (BPD, FML,...), the foetal age and its uncertainty are estimated according to Ob/Gyn curves. For more details on Ob/Gyn curves, see *Appendix F.4, "Setup Sheet", on page 7-44.*

- **Estimated birth date (EBD)**

$$EBD = D LMP + 280 \text{ days}$$

LMP : Last Menstrual Period

- **Numbers of Weeks of Amenorrhea**

$$NWA = D CurrentDate - LMP$$

LMP : Last Menstrual Period

- **Ratios**

$$CI = D \frac{BPD}{OFD} \cdot 100 \quad \text{valid if } 14 \leq AUA \leq 40 \text{ weeks}$$

$$\frac{HC}{AC} \quad \text{valid if } 13 \leq AUA \leq 42 \text{ weeks}$$

$$\frac{FML}{AC} \cdot 100 \quad \text{valid if } 21 \leq AUA \leq 42 \text{ weeks}$$

$$\frac{FML}{BPD} \cdot 100 \quad \text{valid if } 23 \leq AUA \leq 40 \text{ weeks}$$

CI	: Cephalic Index
BPD	: Biparietal Diameter in cm
OFD	: Occipital Frontal Diameter in cm
HC	: Head Circumference in cm
AC	: Abdominal Circumference in cm

- **Calculated abdominal circumference in cm (*AC)**

$$*AC = \frac{\pi \cdot (APD + TAD)}{2}$$

APD : Anterior Posterior Diameter in cm
 TAD : Transabdominal Diameter in cm

- **Calculated head circumference in cm (*HC)**

$$*HC = \frac{\pi \cdot (BPD + OFD)}{2}$$

BPD : Biparietal Diameter in cm
 OFD : Occipital frontal Diameter in cm

- **Average ultrasound age in weeks and days (AUA)**

Average of non zero ultrasound age values calculated on BPD, FML, CRL, AC, HC values.

$$AUA = \frac{\sum_{i=1}^n UA_i}{n}$$

- **Average Estimated birth date (AEBD)**

$$AEBD = CurrentDate - 280 - AUA$$

AUA : Average Ultrasound Age in days

- **Foetal weight (Weight)**

Four methods are proposed: the Shepard and Campbell methods are useful for western population, while Hsieh and Woo methods are for asian people.

- **Shepard method**¹: dependency on Abdominal Circumference and Biparietal Diameter measurements:

$$\log_{10}(Weight) = 1,2508 + 0,166 \cdot BPD + 0,046 \cdot AC - \frac{2,646 \cdot AC \cdot BPD}{1000}$$

AC : Abdominal circumference in cm
 BPD : Biparietal Diameter in cm
 Weight : foetal weight in grams

1. Shepard, M. J. et al., "An Evaluation of Two Equations for Predicting Fetal Weight by Ultrasound", American Journal of Obstetrics and Gynaecology, 1982, Volume 142, Page 47

- **Campbell method¹** : dependency on Abdominal Circumference measurement
The foetal weight is accessed from the reference table shown below :

AC (cm)	Weight (g)	+/-
21	900	130
25	1510	210
31	2690	370
36	3640	490
38	3920	540
40	4100	580

AC : Abdominal circumference in cm

- **Woo method²**: dependency on Abdominal Circumference and Biparietal Diameter measurements:

$$\log_{10}(\text{Weight}) = 1,13 + 0,18 \cdot \text{BPD} + 0,05 \cdot \text{AC} + \frac{3,35 \cdot \text{AC} \cdot \text{BPD}}{1000}$$

AC : Abdominal circumference in cm
BPD : Biparietal Diameter in cm
Weight : foetal weight in gramms

- **Hsieh method³**: dependency on Abdominal Circumference and Biparietal Diameter-
measurements:

$$\log_{10}(\text{Weight}) = 5,6541 \cdot \frac{\text{AC} \cdot \text{BPD}}{1000} + 1,5515 \cdot \frac{\text{AC}^2 \cdot \text{BPD}}{10000} + 0,19782 \cdot \frac{\text{AC}^3}{100000} + 0,52594 \cdot \frac{\text{BPD}}{100} + 2,13153$$

AC : Abdominal circumference in cm
BPD : Biparietal Diameter in cm
Weight : foetal weight in gramms

1. Campbell, D. Wilkin, "Ultrasonic Measurement of Fetal Abdomen circumference in the estimation of fetal weight", British Journal of Obstetrics and Gynaecology, Sept. 1975, Volume 82, No 9, pages 689 to 697
2. "Clinical Validation of Two Equations in Antenatal Prediction of Chinese Fetal Weight by Ultrasonography", FM Chang, HC Ko, BL Yao, CH Wu (J. Formosan Med. Assoc. 1991; 90:1086-92)
3. "Clinical Validation of Two Equations in Antenatal Prediction of Chinese Fetal Weight by Ultrasonography", FM Chang, HC Ko, BL Yao, CH Wu (J. Formosan Med. Assoc. 1991; 90:1086-92)

F.2 TM/SP Sheet

F.2.1 Description

14/01/98 08:30:31

LAB. :
 OPER. :
 NAME :
 EXAM.N: HR : ... b/mn

___ OB/GYN STUDIES _____

HEART RATE: _ b/mn

Velocity: _____ m/s Frequency: _____ kHz





ARTERIES Uterine L. Uterine R. Umbilical Cerebral

PI

*TAMX[m/s]	_____	_____	_____	_____
*VELs[m/s]	_____	_____	_____	_____
*VELd[m/s]	_____	_____	_____	_____
ÆVELs/VELd	_____	_____	_____	_____

RI

*VELs[m/s]	_____	_____	_____	_____
*VELd[m/s]	_____	_____	_____	_____
ÆVELs/VELd	_____	_____	_____	_____

F.2.2 Second function keys page

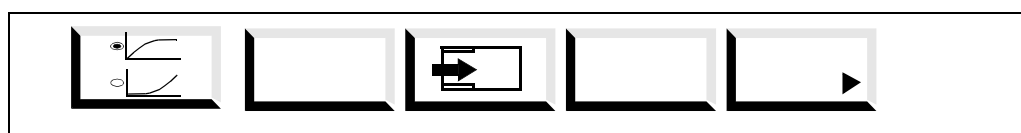

F.2.2.1 TM and SP Measurement

Heart Rate : Foetal Heart Rate in b/mn

F.2.2.2 SP Measurement

a) Velocity and Frequency measurement

Velocity : Velocity in m/s
 Frequency : Frequency in kHz

When one of these fields is measured, the others is automatically computed.

b) Resistance and Pulsatility Index:

Four groups of measurement are available: Uterine Left, Uterine Right, Umbilical and Cerebral. For each group the following measurements are available:

- *Vels : Velocity at Systole in m/s
- *Veld : Velocity at Diastole in m/s
- *TAMX : Mean Velocity in m/s
- RI : Resistance Index
- PI : Pulsatility Index
- ÆVels/Veld : Ratio Velocity Systole/Diastole

The resistance index can be either deduced from the PI calculation or computed separately. Since it can be computed separately, some parameters are duplicated.

F.2.3 Equation

- Time Average Maximum Velocity in metres per second (TAMX)

$$TAMX = \frac{VTI}{Time}$$

- VTI : Velocity Time Integral
- Time : Duration flow in seconds

- Resistance Index from Pourcelot (RI)

$$RI = \frac{Vels - Veld}{Vels}$$

- Vels : Velocity at systole m/s
- Veld : Velocity at diastole in m/s

- Pulsatility Index

$$PI = \frac{Vels - Veld}{TAMX}$$

- Vels : Velocity at systole m/s
- Veld : Velocity at diastole in m/s
- TAMX : Time Average Maximum Velocity in m/s

F.3 Foetal Information Sheet

To access this page, the user must select the



icon from one of the previous screens.

If the user selects the

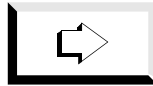

icon from the fetal information sheet, the 2D or SP/TM sheet will be displayed again, according to the current mode (2D, TM, ...)..

14/02/01 08:30:31

LAB. :

OPER. :

NAME :

EXAM.N:

___ PAROUS EXPERIENCE _____

GRAVIDITAS : ... PARA Term : ...

Prema : ...

Abortion : ...

Living : ...

___ FETAL DESCRIPTION _____

GENDER :

FETAL MOVEMENT :

FETAL BREATHING :





CARDIAC ACTIVITY :

.....

PRESENTATION :

.....

.....

Second function keys page

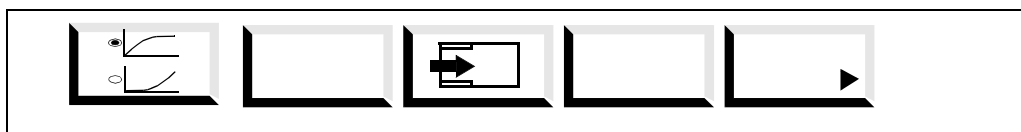

Information concerning Mother:

- GRAVIDITAS : Number of pregnancies
- Term : Number of birthes having reached time
- Prema : Number of premature birthes
- Abortion : Number of abortion
- Living : Number of alive infant at birth

Information concerning Foetus:

- FOETAL HEART RATE
- FOETAL MOUVEMENT
- FOETAL BREATHING
- GENDER : most likely sex made on 2D images
- PRESENTATION

F.4 Setup Sheet

F.4.1 Description

The calculations collected in the obstetric/gynaecology package are designed to estimate the age of a foetus according to the size of a specific body element (e.g., femur length, thoracic diameter,...). The age is subsequently determined, using a reference table, where a linear interpolation is made for each measurement which lies between two tabulated points. For each measurement, the user can use his personal table (see *Appendix F.5, "User Table Sheet", on page 7-47*), or a reference table.

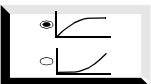
To select the curves he wants to work with, the user must enter the user setup sheet by selecting the  softkey. The following screen is then displayed.

- **First Page**

14/02/01 08:30:31

OB / GYN SETUP

<p><u>CRL</u></p> <p>÷Robinson</p> <p>Hohler</p> <p>Chev/Jean</p> <p>Hansmann</p> <p>Rempen</p> <p>User</p> <p><u>GES</u></p> <p>÷Ramzin</p> <p>Hellman</p> <p>Hansmann</p> <p>User</p>	<p><u>ChD</u></p> <p>÷Rempen</p> <p>User</p> <p><u>BPD</u></p> <p>÷Bessis</p> <p>Merz</p> <p>Hadlock</p> <p>Campbell</p> <p>Chev/Hobb</p> <p>Hohl/Sabb</p> <p>Hansmann</p> <p>Lai/Yeo</p> <p>User</p>	<p><u>BOD</u></p> <p>÷Jeanty</p> <p>User</p> <p><u>OFD</u></p> <p>÷Merz</p> <p>User</p> <p><u>HC</u></p> <p>÷Hadlock</p> <p>Merz</p> <p>Lai/Yeo</p> <p>User</p>
--	--	---

✓





The user selects a curve using the trackball and validates his choice with the <CURSOR_SET> key. A tick is displayed in front of the selected curve.

If the user wants to work with his own curves, he selects the "USER" item. A specific screen is displayed (see *Appendix F.5, "User Table Sheet", on page 7-47*).

The user can also display an ob/gyn curve; once the curve label is video inverted, he presses the  icon.

- Second page

14/02/01 08:30:31

OB / GYN SETUP

<u>TAD</u> †Merz User	<u>THD</u> †Hansmann User	<u>HuL</u> †Merz Lai/Yeo User
<u>APD</u> †Ramzin Bessis Merz User	<u>FML</u> †Bessis Hadlock Obri/Camp Jeanty Hohler Merz Hansmann Lai/Yeo User	<u>WEIGHT</u> †Shepard Campbell Hsieh Woo
<u>AC</u> †Hadlock Merz Lai/Yeo User		

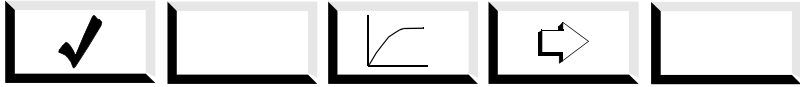

F.4.2 Short Description of Reference Tables

The following table summarizes the reference tables. For more information, see the related page in appendix 7.

Meas	Author	Sound velocity (m/s)	Meas range (cm)	Age range (wk)	Error range (wk)	
AC	Hadlock	1540	10-36.5	15.6-40.8	1.9-2.5	page 7-78
AC	Merz	1540	6.2-34.3	12.5-41.5	1.2-3.6	page 7-79
AC	Lai/Yeo	1540	8.7-34.1	15-41	0.8-2.1	page 7-80
APD	Bessis	1540	2.5-8.8	14-37.2	1.2-4.8	page 7-69
APD	Merz	1540	1.9-10.9	12.5-41.5	1.2-3.5	page 7-70
APD	Ramzin	1540	5.18-10	22-40	3.5-4.5	page 7-69
BOD	Jeanty	1540	1.5-6.5	10.4-40.1	0.7-2	page 7-84
BPD	Bessis	1540	1.9-9.7	11.6-39.9	0.8-4.5	page 7-49
BPD	Campbell	1540	2.3-9.8	13.1-40	0.2-2.2	page 7-50
BPD	Hadlock	1540	2-10	12.2-42	0.8-3.6	page 7-51
BPD	Hansmann	1600	1.6-9.8	11-39	1.2-5	page 7-52
BPD	Hobbins	1540	1-6.8	9.1-26.4	2.7-2.7	page 7-54
BPD	Hohler	1540	2-10	11.8-42.1	0-0	page 7-55
BPD	Merz	1540	2.5-9.8	12.5-41.5	1.2-5.5	page 7-53

BPD	Lai/Yeo	1540	2.5-9.6	14-41	0.8-3.3	page 7-56
ChD	Rempen	1540	0.2-7.3	4.86-14.14	0.8	page 7-57
CRL	Hansmann	1600	1.3-16.0	8-22	1.5-2.5	page 7-74
CRL	Hohler	1540	0.6-7.8	6.3-14	0.34-0.34	page 7-72
CRL	Jeanty	1540	0.6-5.4	6.6-12.1	0.7-0.7	page 7-73
CRL	Rempen	1540	0.2-7.8	6-13.71	1.4	page 7-75
CRL	Robinson	1540	0.42-7.78	6-14	0.6-0.8	page 7-71
FML	Bessis	1540	1.04-7.34	13-41	1.0-4	page 7-58
FML	Hadlock	1540	1-7.9	12.8-40.4	0.7-1.6	page 7-59
FML	Hansmann	1600	1.4-7.5	15-40	1.0-3.5	page 7-62
FML	Hohler	1540	1-8	12-40.8	0-0	page 7-61
FML	Jeanty	1540	1-8	12.6-40	1.4-1.4	page 7-60
FML	O'Brien	1540	1-4.6	12-23.5	0.5-0.5	page 7-60
FML	Merz	1540	0.9-7.7	12.5-41.5	0.25-4	page 7-63
FML	Lai/Yeo	1540	1.3-7.3	14-41	0.8-2.7	page 7-64
GES	Hansmann	1540	0.7-3.4	2.9-7	1.1-1.1	page 7-77
GES	Hellman	1540	0.4-4.7	4.7-10.3	1-1	page 7-76
GES	Ramzin	1540	0.77-5.71	5-12	1.2-1.2	page 7-76
HC	Hadlock	1540	8-36	13.4-41.6	1.3-3.4	page 7-81
HC	Merz	1540	9.2-35	12.5-41.5	1-5.8	page 7-82
HC	Lai/Yeo	1540	8.6-33	14-41	0.8-4	page 7-83
HuL	Merz	1540	0.8-6.7	12.5-41.5	0.7-4.5	page 7-65
HuL	Lai/Yeo	1540	1.9-6.1	16-41	1-4	page 7-66
OFD	Merz	1540	3-11.5	12.5-41.5	1-6.5	page 7-84
TAD	Merz	1540	2-11	12.5-41.5	1-3.5	page 7-67
THD	Hansmann	1540	3.1-10.8	15.5-41	1.9-4.1	page 7-68

F.5 User Table Sheet

14/01/98 08:30:31

OB / GYN SETUP

Sound velocity: 1540

	cm	wk	+/-
1.
2.
3.
4.
5.
6.
7.
8.
9.
0.







When the user selects the USER item in the setup sheet, this page is displayed.

The user can here enter his own curve. The default sound velocity is set to 1540 m/s (reference value). The user can enter a different value. In this case, the system automatically performs a ratio between the reference value and the user velocity before computing the interpolation.

If he presses the  icon, his curve is drawn on screen.

Note: the week and uncertainty values must be entered in week as a floating value (3 weeks and 2 days = 3.3 weeks).

F.6 Curve View



When the user presses on the  icon from one of the previous screens while a measurement field (BPD, FML,...) or a gestational curve (Bessis in BPD group) is highlighted, the corresponding curve is drawn on the screen. Others informations are also displayed as the measured length, the NWA, the age.

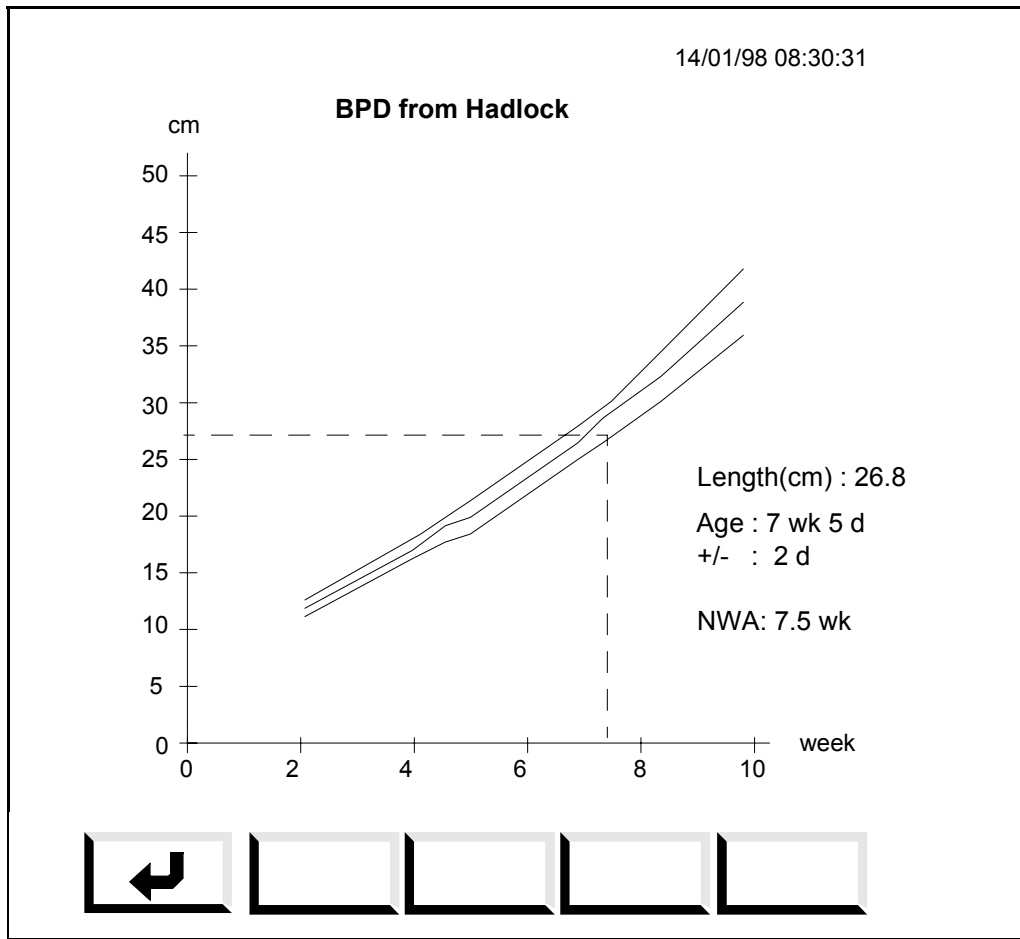

A point is displayed on the curve graph. This point matches the estimated information (Age, length) if the NWA is lower than 15 weeks. When NWA is equal or greater than 15 weeks, the displayed point matches the (NWA, length) information.

Appendix G: Reference Tables for Ob/Gyn

G.1 Biparietal Diameter (BPD)

G.1.1 BPD from Bessis

BPD (cm)	EBD (week)	+/-
1.9	11.6	0.8
2.35	13	0.8
3.65	17	0.8
4.9	21	1
6.05	25	1.3
7.2	29	1.7
8.15	33	2.6
8.75	37	4.5
9.7	39.9	4.5

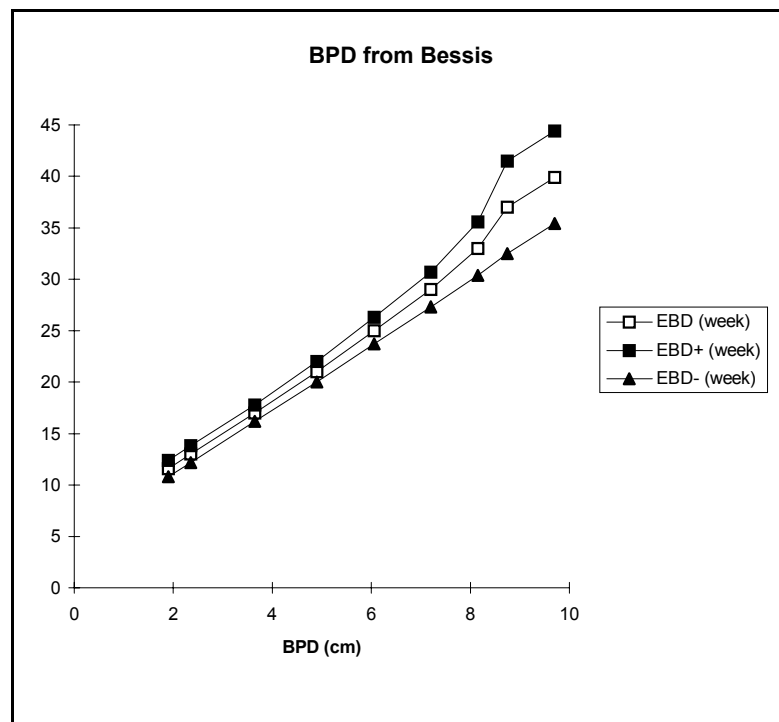

G.1.1.1 Source: The data are those provided by Dr. Bessis to M. Le Bel. (Same as SIGMA 20, see memo from Ch. Gähwiller dated, June 23, 1983)

G.1.2 BPD from Campbell

BPD (cm)	EBD (week)	+/-
2.3	13.1	0.2
3.4	15.2	0.4
5.7	22	0.4
6.4	23.9	0.5
7.5	27.7	0.6
8.9	33.2	1
9.5	37	1.9
9.8	40	2.2

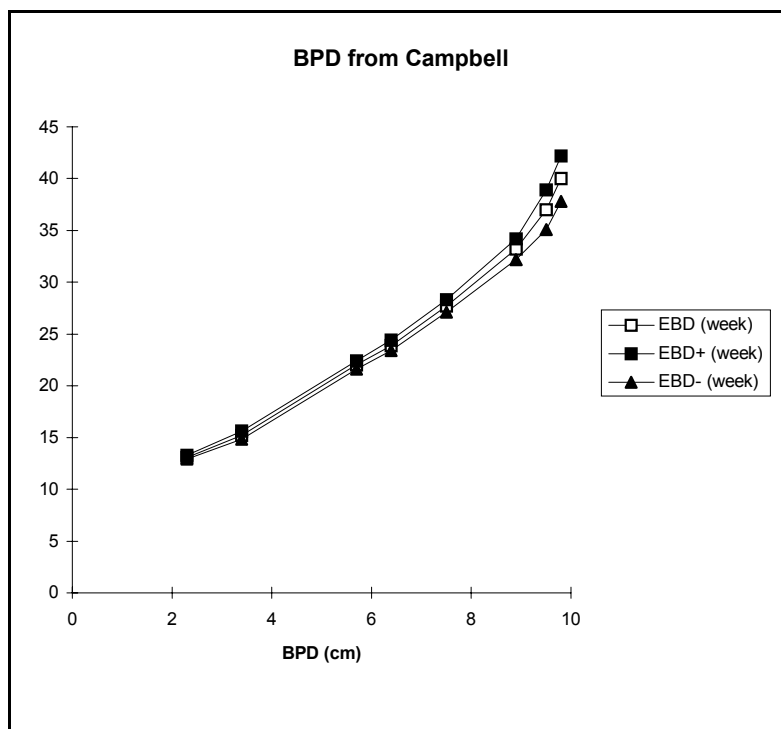

G.1.2.1 Source: S. Campbell; G.B. Newman. Growth of the fetal biparietal diameter during normal pregnancy. *The Journal of Obstetrics and Gynaecology of the British Commonwealth*. 78:513, June 1971.

G.1.3 BPD from Hadlock

BPD (cm)	EBD (week)	+/-
2	12.2	0.8
4	18	0.8
4.5	19.5	1.39
5	21.2	1.39
7	28.3	1.34
7.5	30.4	2
8.5	34.7	2
10	42	3.6

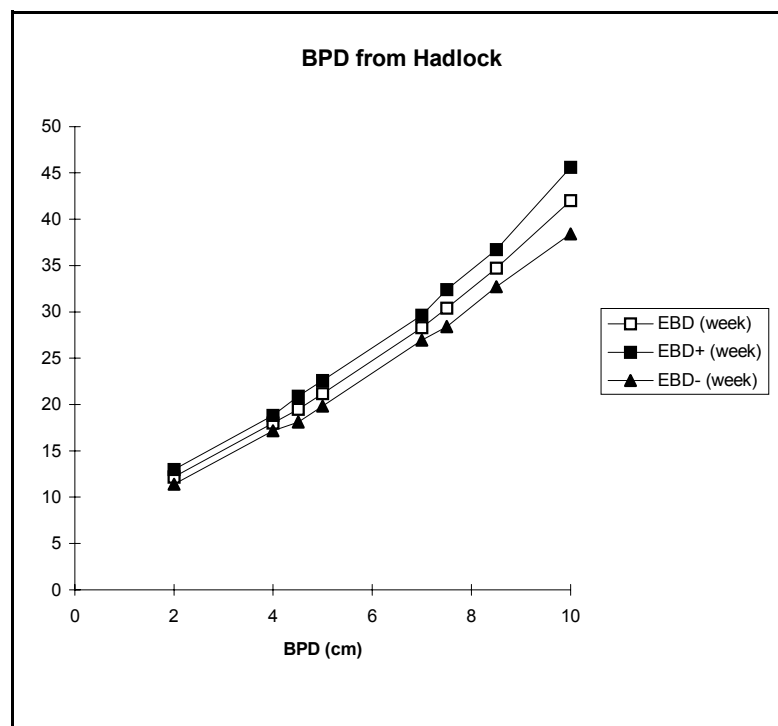

G.1.3.1 Source: Hadlock, F.P.: Deter, R.L.: Harist, B.: Park, S.K. Fetal Biparietal Diameter: A Critical Re-evaluation of the Relation to Menstrual Age by Means of Real-time Ultrasound. *J. Ultrasound Med.* 1:97, April 1982.

G.1.4 BPD from Hansmann

BPD (cm)	EBD (week)	+/-
1.6	11	1.2
2.4	13	1.2
3.8	17	1.2
5.2	21	1.5
6.5	25	2
7.7	29	3
8.5	32	3.5
9.5	37	5
9.8	39	5

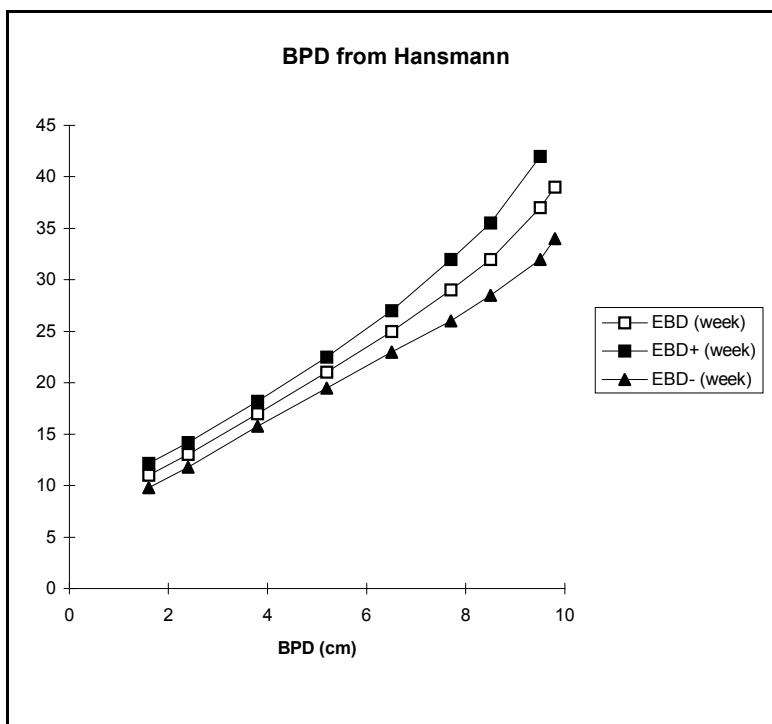

G.1.4.1 Source: The values provide from A. De Lavernette (Kontron France).
Author Dr. Hansmann

G.1.5 BPD from Merz

BPD (cm)	EBD (week)	+/-
2.5	12.5	1.5
3.5	16	1.2
4.6	19	1.2
5.7	22.5	1.5
6.7	25.5	1.6
7.7	29	2
8.5	32	2.5
9.2	35.5	4.2
9.6	38.5	4
9.8	41.5	5.5

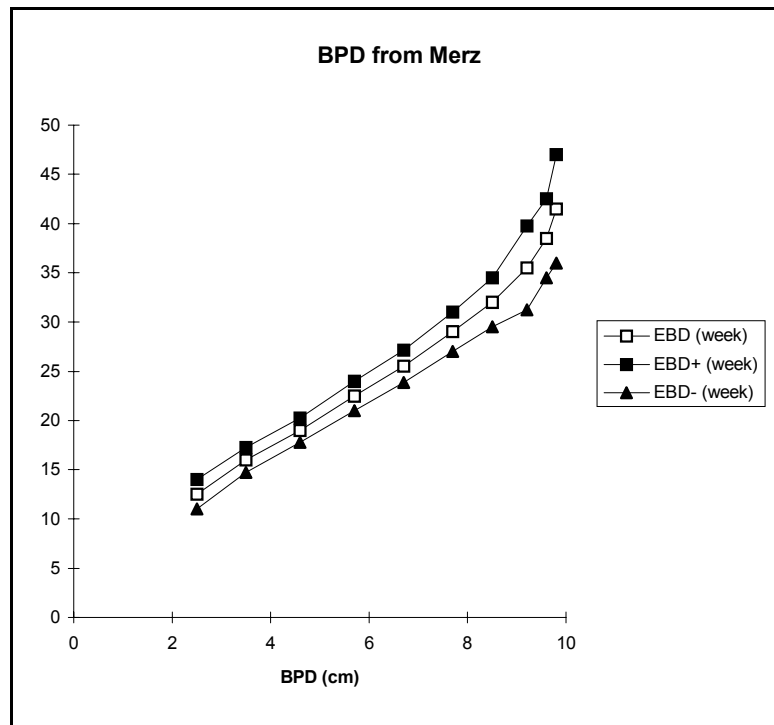

G.1.5.1 Source: Eberhard Merz "Ultrasound in Gynecology and Obstetrics", Textbook and Atlas, 1991, Georg Thieme Verlag

G.1.6 BPD from Hobbins

BPD (cm)	EBD (week)	+/-
1	9.1	2.7
2.6	13.4	2.7
4.6	19	2.7
5.6	22.1	2.7
6.8	26.4	2.7

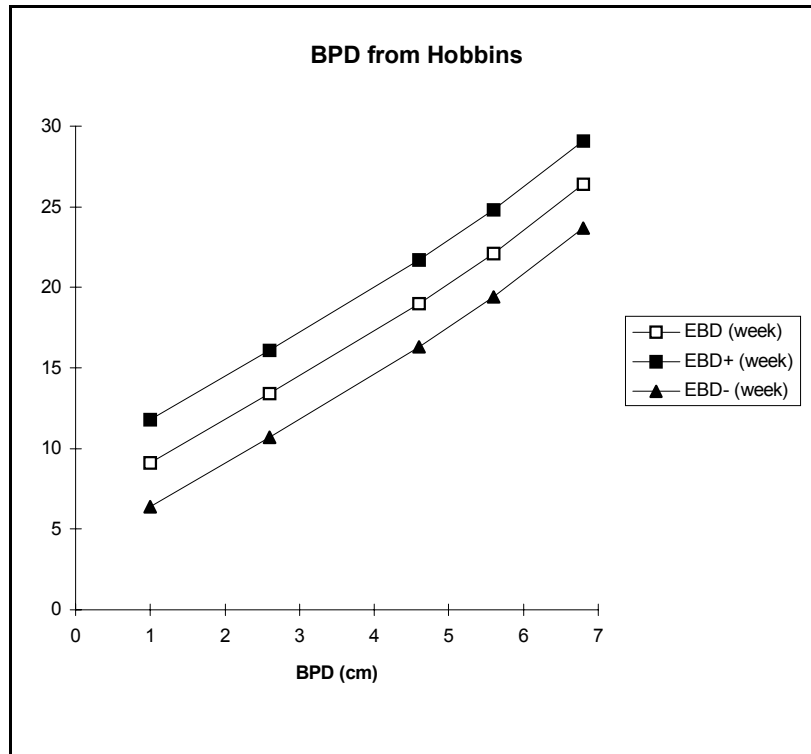

G.1.6.1 Source: Chervenak, F.A.: Jeanty, P.: Hobbins, J.C.: Current Status of Fetal Age and Growth Assessment.

G.1.7 BPD from Hohler

BPD (cm)	EBD (week)	+/-
2	11.8	0
4.5	17.3	0
5.5	22	0
7	27.3	0
8	31.3	0
9	36.1	0
10	42.1	0

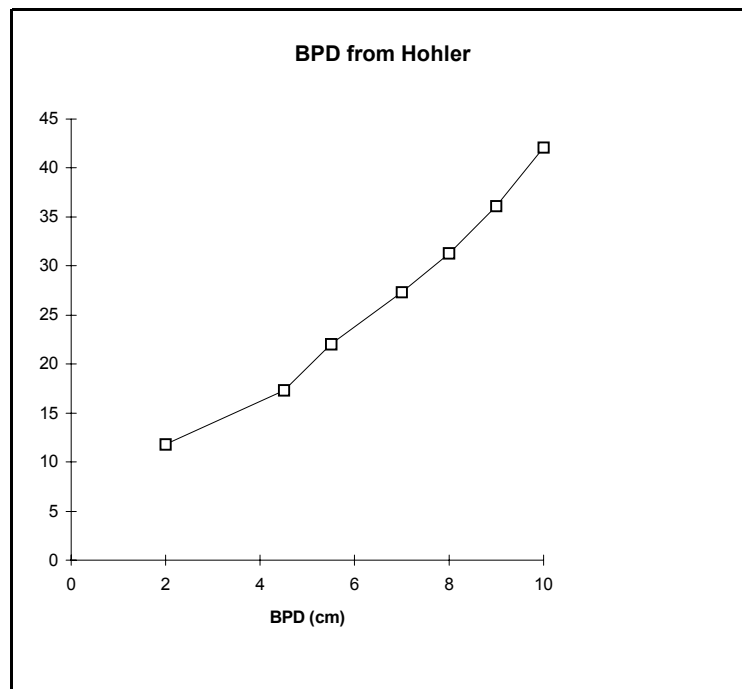

G.1.7.1 The table values have been adapted from Sabbagha by Hohler.

Sabbagha, R.E.: Hughey, F.&M. Standardization of Sonar Cephalometry and Gestational Age. *Obstet. Gynecol.* 52:402-406, 1978.

G.1.8 BPD from Lai/Yeo

BPD (cm)	EBD (week)	+/-
2.85	14.8	0.8
4.38	19.0	0.9
5.39	22.0	1.0
6.33	25.0	1.2
7.18	28.0	1.4
7.93	31.0	1.7
8.37	33.0	1.9
8.76	35.0	2.4
9.09	37.0	3.0
9.19	37.7	3.3

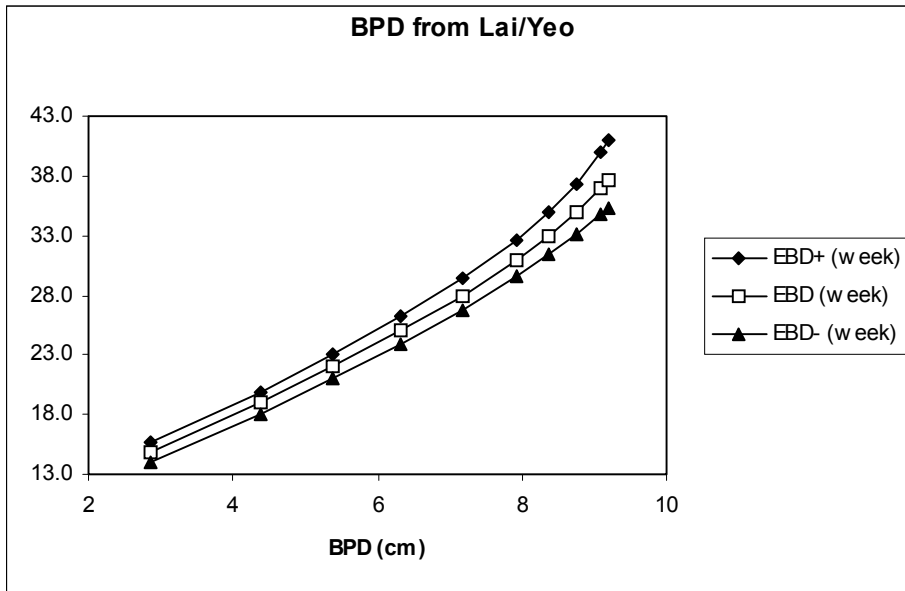

G.1.8.1 Source: F.M. Lai, G.S.H Yeo: Reference Charts of foetal biometry in Asian, Singapore Med J 1995; Vol 36: 628-636

G.2 Chorion Diameter (ChD) from Rempen

ChD (cm)	EBD (week)	+/-
0.2	4.86	1.4
1	5.71	1.4
1.8	6.72	1.4
2.6	7.55	1.4
3.4	8.59	1.4
4.2	9.69	1.4
5	10.73	1.4
5.8	11.85	1.4
6.6	13	1.4
7.3	14.14	1.4

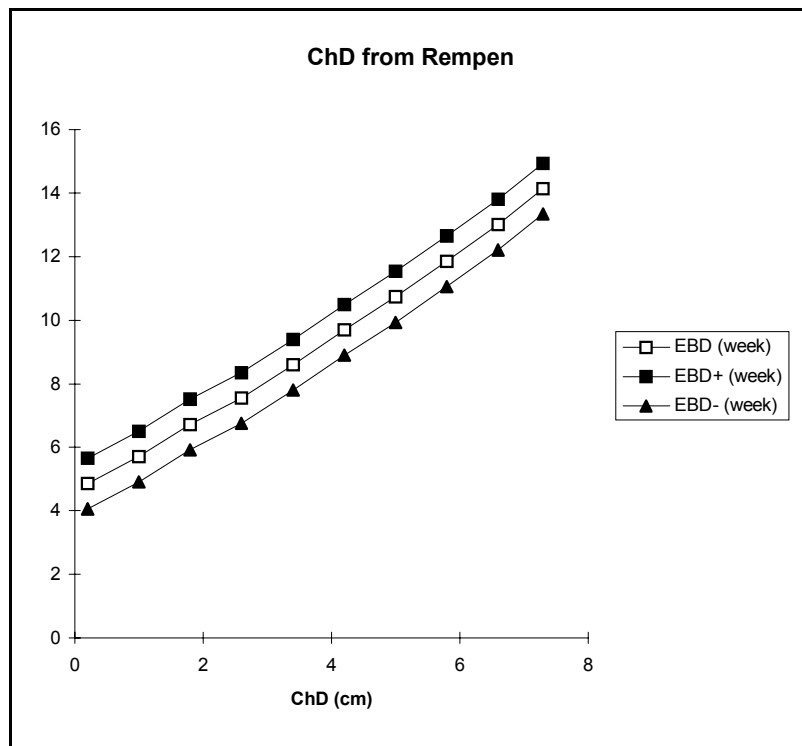

G.3 Femur Length (FML)

G.3.1 FML from Bessis

FML (cm)	EBD (week)	+/-
1.04	13	1
2.22	17	1.1
3.37	21	1.2
4.45	25	1.4
5.42	29	1.6
6.42	33	2.1
6.9	37	2.9
7.34	41	4

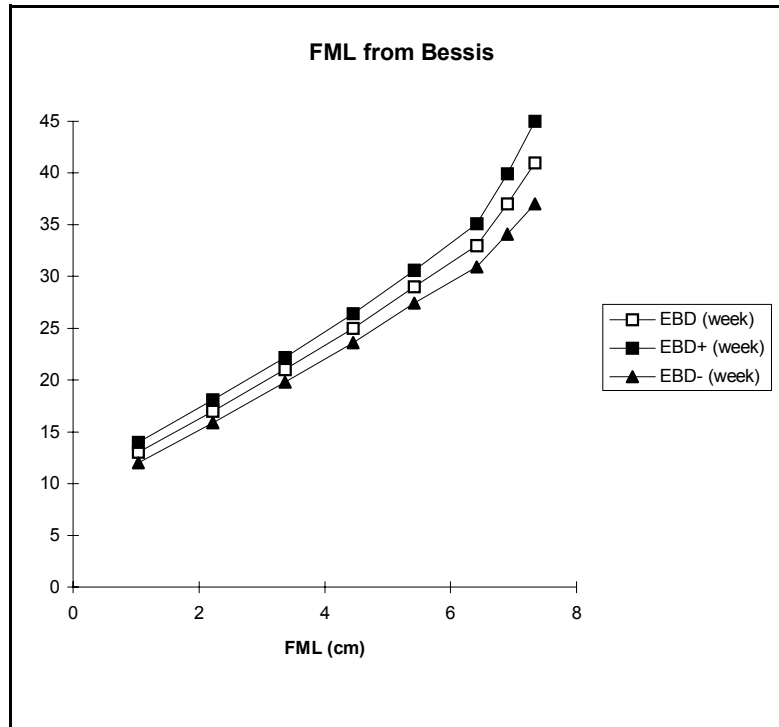

G.3.1.1 Source: The data are those provided by Dr. Bessis to M. Le Bel. (Same as SIGMA 20, see memo from Ch. Gähwiller dated, June 23, 1983)

G.3.2 FML from Hadlock

FML (cm)	EBD (week)	+/-
1	12.8	0.7
2	15.7	0.7
2.5	17.2	1.6
5	26.5	1.6
7.9	40.4	1.6

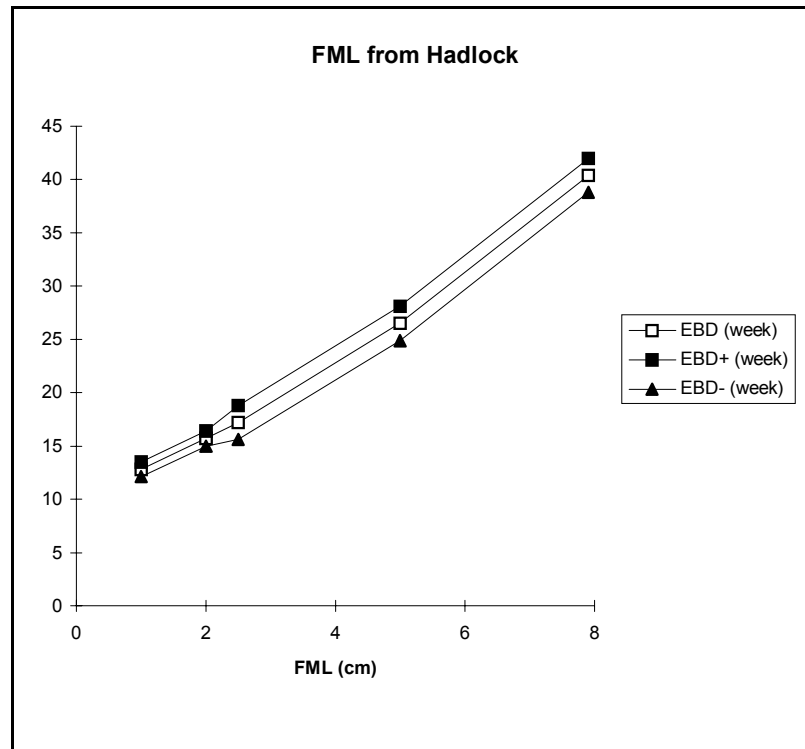

G.3.2.1 Source: publication

Title: *Fetal Femur Length as a Predictor of Menstrual Age: Sonographically Measured.*

Authors: *F.P. Hadlock, R.B. Harrist, R.L. Deter, S.K. Park*

Reference: *American Journal Roentgenology, Vol 138, May 1982*

G.3.3 FML from O'Brien

FML (cm)	EBD (week)	+/-
1	12	0.5
4.6	23.5	0.5

G.3.3.1 Source: Jeanty, P.: Rodesh, F.: Delbeke, D.: Dumont, J.: Estimation of Gestational Age from Measurements of Fetal Long Bones. *J. Ultrasound Med.* 3:75, 1984.

G.3.4 FML from Jeanty

FML (cm)	EBD (week)	+/-
1	12.6	1.4
2	15.9	1.4
3	19.4	1.4
4	23.1	1.4
5	27	1.4
6	31.1	1.4
7	35.5	1.4
8	40	1.4

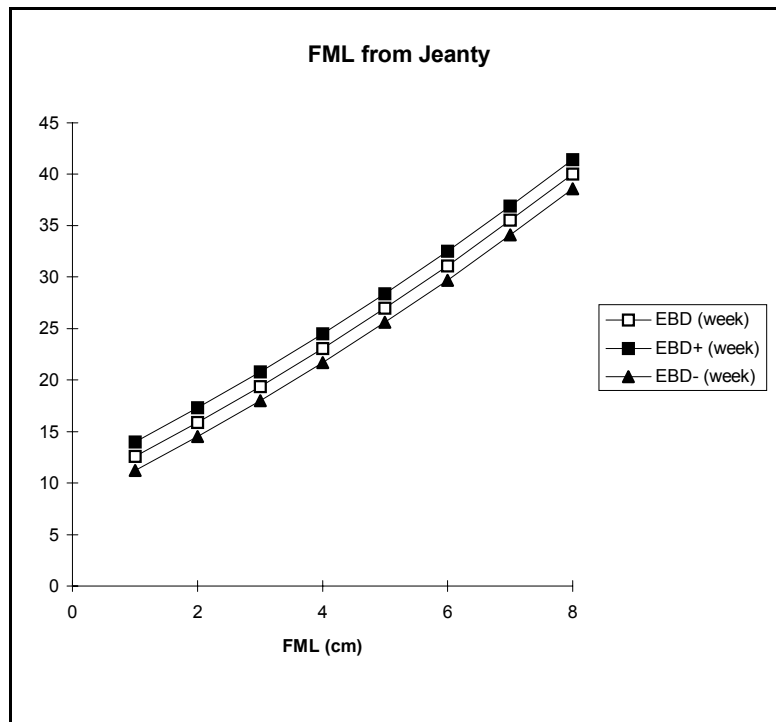

G.3.4.1 Source: Jeanty, P.: Rodesh, F.: Delbeke, D.: Dumont, J.: Estimation of Gestational Age from Measurements of Fetal Long Bones. *J. Ultrasound Med.* 3:75, 1984.

G.3.5 FML from Hohler

FML (cm)	EBD (week)	+/-
1	12	0
2.5	16.9	0
5	23.5	0
6	31	0
7	35.7	0
8	40.8	0

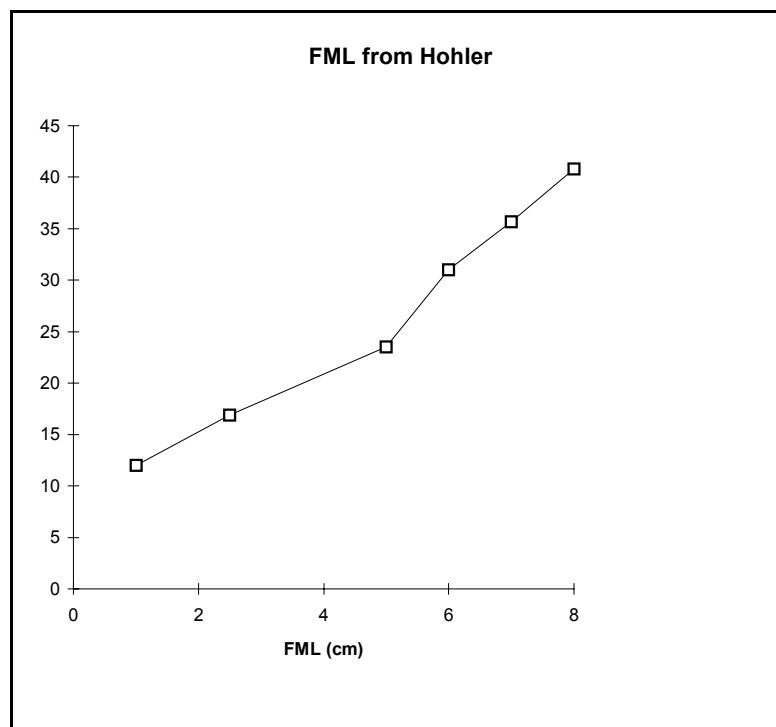

G.3.5.1 Source: Hohler, C.W.: Quetel, T.A.

Fetal femur length: Equations for computer calculation of gestational age from ultrasound measurements.

Am. J. Obstet. Gynecol. 143:479-481, 1982.

G.3.6 FML from Hansmann

FML (cm)	EBD (week)	+/-
1.4	15	1
2.6	19	1.5
3.5	22	1.7
4.3	25	2
5.1	28	2.5
6	32	3
6.8	36	3.3
7.5	40	3.5

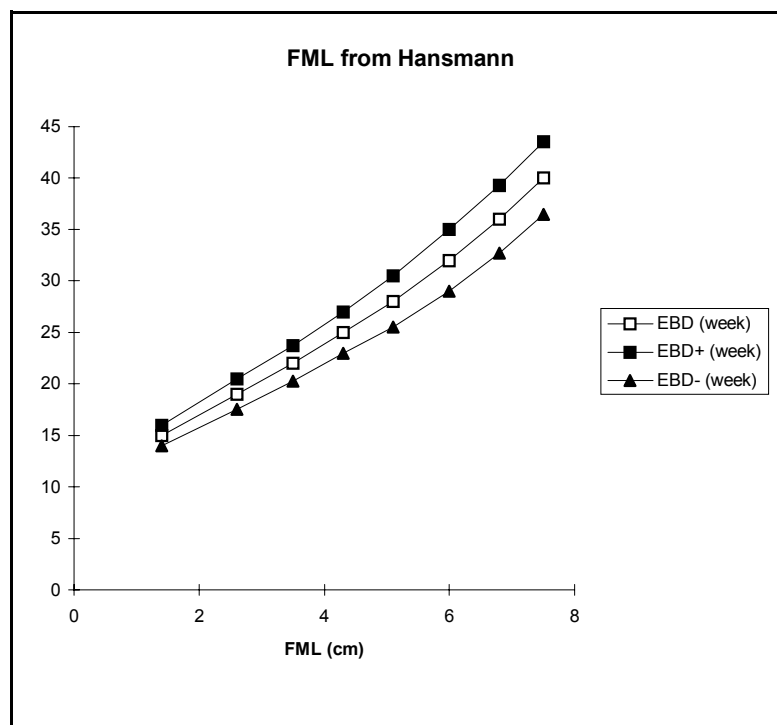

G.3.6.1 Source: Prof. Dr. Hansmann, Prof. Dr. Hackelöer und Prim. Prof. Dr. Staudach "Ultraschalldiagnostik in Geburtshilfe und Gynäkologie", p. 413+418, ISBN Nr. 3-540-11428-9, Springer-Verlag

G.3.7 FML from Merz

FML (cm)	EBD (week)	+/-
0.9	12.5	0.2
2.1	16	1
3	19	1.2
4	22.5	1.5
4.8	25.5	1.7
5.6	29	2.1
6.2	32	2.2
6.9	35.5	2.7
7.4	38.5	3
7.7	41.5	4

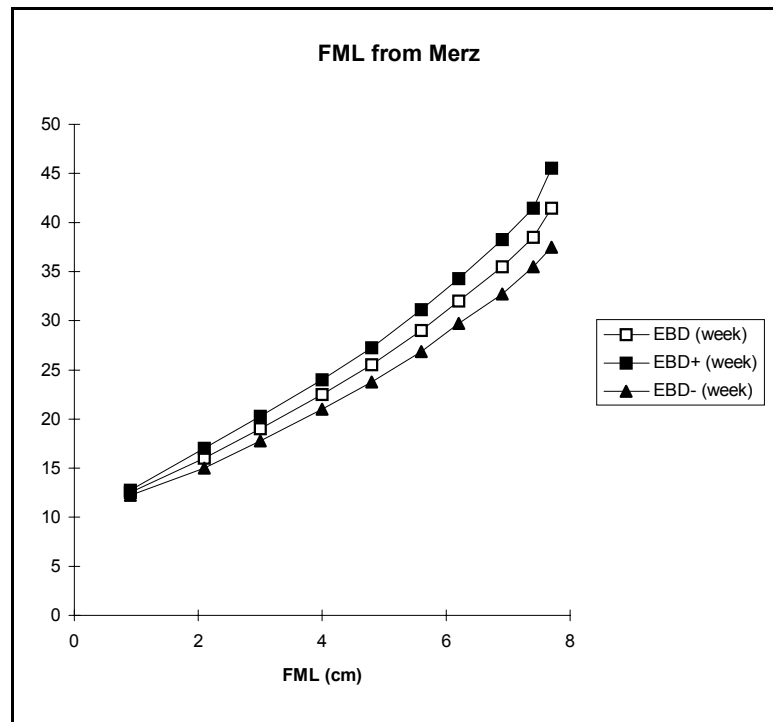

G.3.7.1 Source: Eberhard Merz "Ultrasound in Gynecology and Obstetrics", Textbook and Atlas, 1991, Georg Thieme Verlag

G.3.8 FML from Lai/Yeo

FML (cm)	EBD (week)	+/-
1.6	14.8	0.8
2.5	18.0	0.9
3.0	20.0	1.0
4.1	24.0	1.1
4.6	26.0	1.2
5.3	29.0	1.4
5.7	31.0	1.6
6.3	34.0	1.8
6.8	37.0	2.3
6.9	38.3	2.7

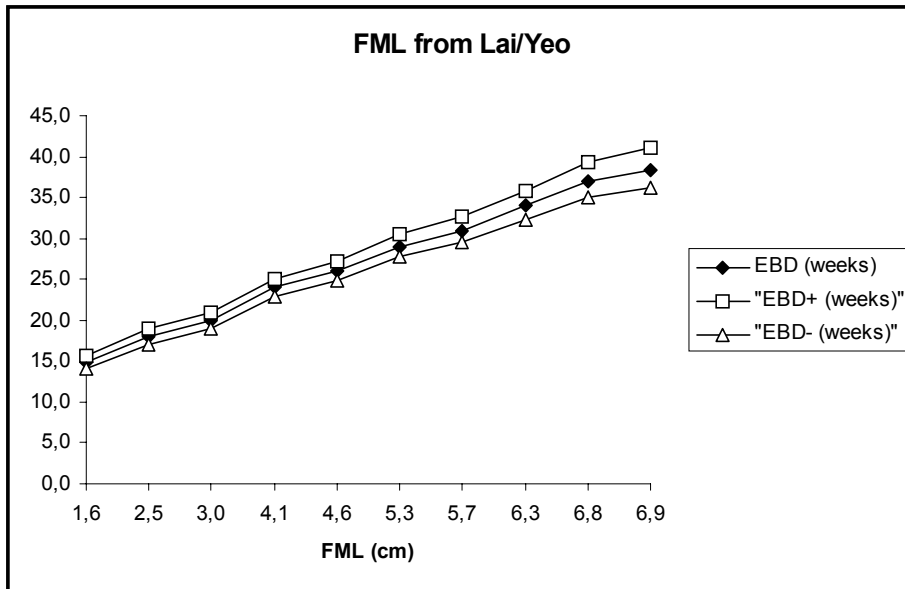

G.3.8.1 Source: F.M. Lai, G.S.H Yeo: Reference Charts of foetal biometry in Asian, Singapore Med J 1995; Vol 36: 628-636

G.4 Humerus Length (HuL)

G.4.1 Humerus Length (HuL) from Merz

HuL (cm)	EBD (week)	+/-
0.8	12.5	0.7
2	16	1
2.8	19	1.4
3.7	22.5	1.5
4.3	25.5	1.7
5	29	2
5.5	32	2.5
6.1	35.5	3.2
6.4	38.5	3.5
6.7	41.5	4.5

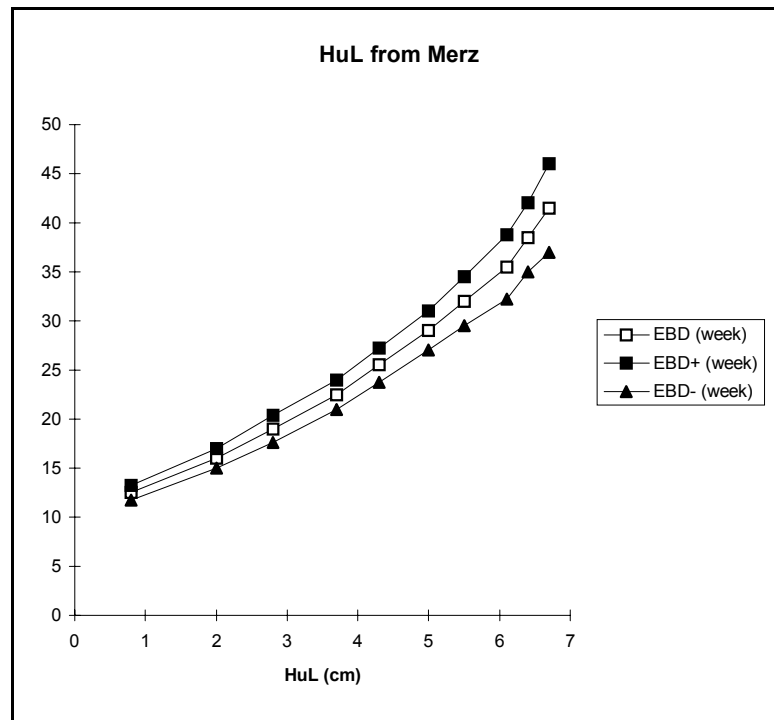

G.4.1.1 Source: Eberhard Merz "Ultrasound in Gynecology and Obstetrics", Textbook and Atlas, 1991, Georg Thieme Verlag

G.4.2 HuL from Lai/Yeo

HuL (cm)	EBD (week)	+/-
2.2	17.0	1.0
2.4	18.0	1.0
3.3	22.0	1.2
3.9	25.0	1.5
4.5	28.0	1.7
4.8	30.0	1.9
5.1	32.0	2.3
5.4	34.0	2.8
5.7	36.0	3.3
5.8	37.0	4.0

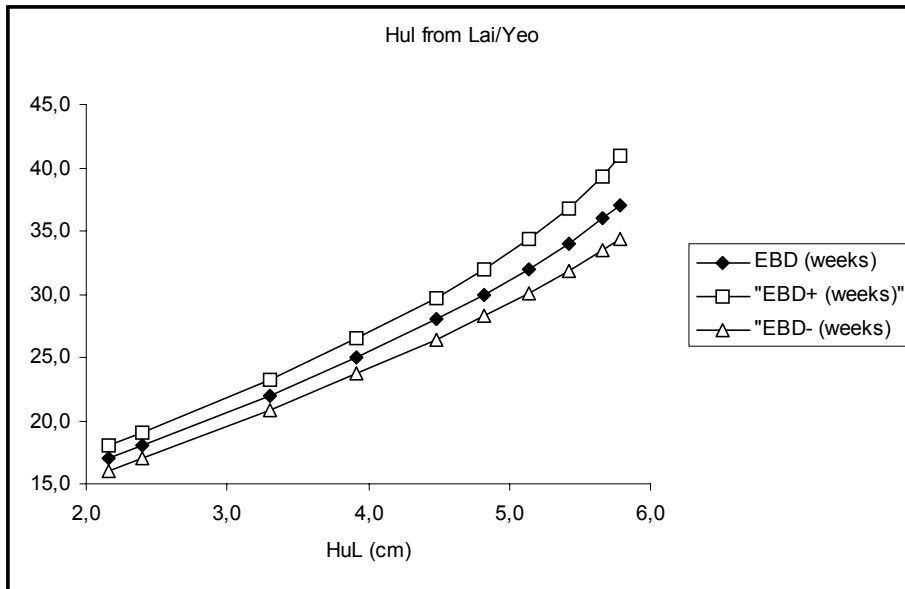

G.4.2.1 Source: F.M. Lai, G.S.H Yeo: Reference Charts of foetal biometry in Asian, Singapore Med J 1995; Vol 36: 628-636

G.5 Transabdominal Diameter (TAD) from Merz

TAD (cm)	EBD (week)	+/-
2	12.5	1
3.2	16	1.2
4.3	19	1.6
5.5	22.5	1.6
6.5	25.5	1.7
7.6	29	2
8.5	32	2.4
9.6	35.5	2.9
10.4	38.5	2.7
11	41.5	3.5

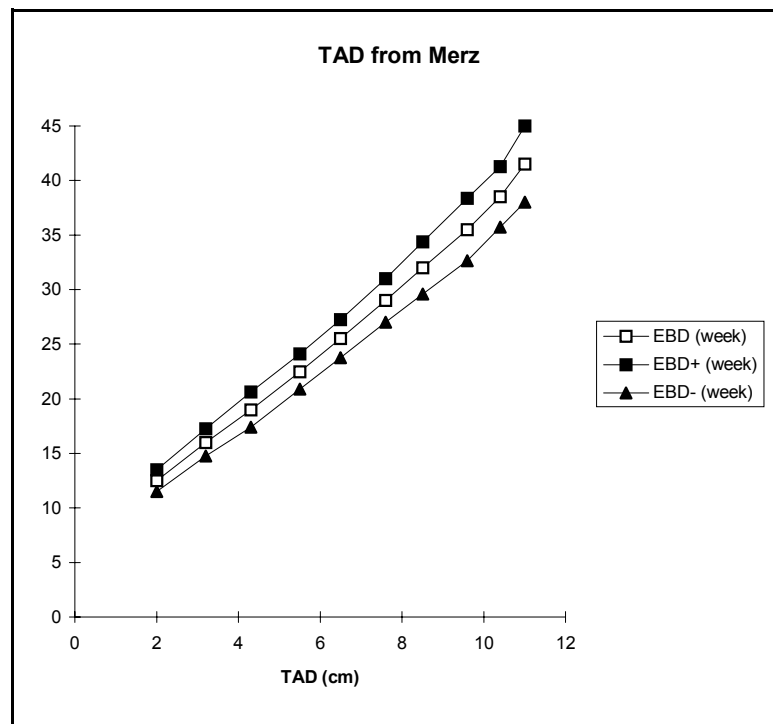

G.5.0.1 Source: Eberhard Merz "Ultrasound in Gynecology and Obstetrics", Textbook and Atlas, 1991, Georg Thieme Verlag

G.6 Thoracic Diameter (THD) from Hansmann

THD (cm)	EBD (week)	+/-
3.1	15.5	1.9
5.19	22.5	2.5
7.79	31.5	3.3
9.35	36	3.7
10.8	41	4.1

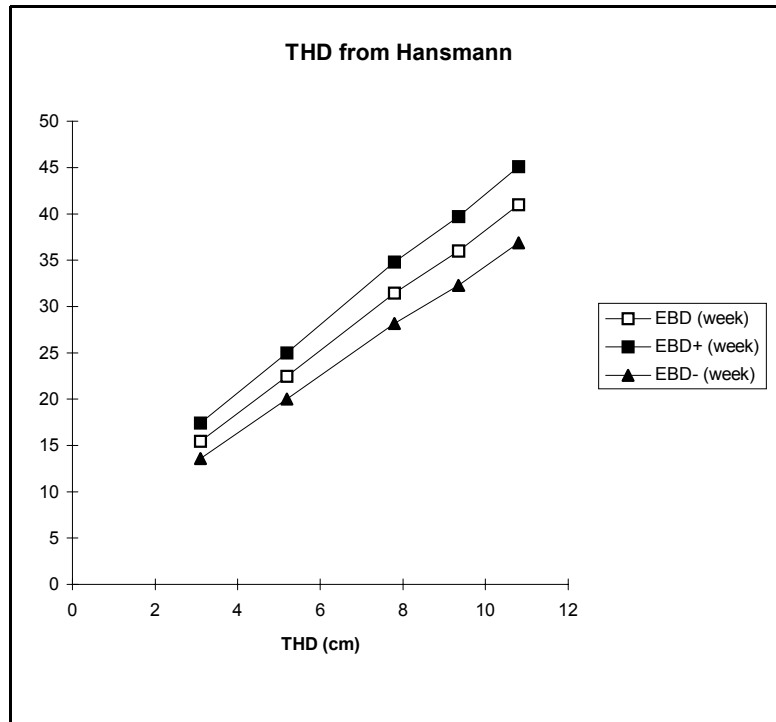

G.6.0.1 Source: Hansmann (Ellison Roynon, Kontron Medical)

Sound Velocity: 1540 m/s (Values are scaled from a sound velocity of 1600 m/s as in the publication, 1540 m/s for the table).

Uncertainty: two standard deviation.

G.7 Anterior Posterior Diameter (APD)

G.7.1 APD from Ramzin

APD (cm)	EBD (week)	+/-
5.18	22	3.5
10	40	4.5

G.7.1.1 Source: Dr. Ramzin, Basel
 Sound Velocity: 1540 m/s
 Uncertainty: two standard deviation

G.7.2 APD from Bessis

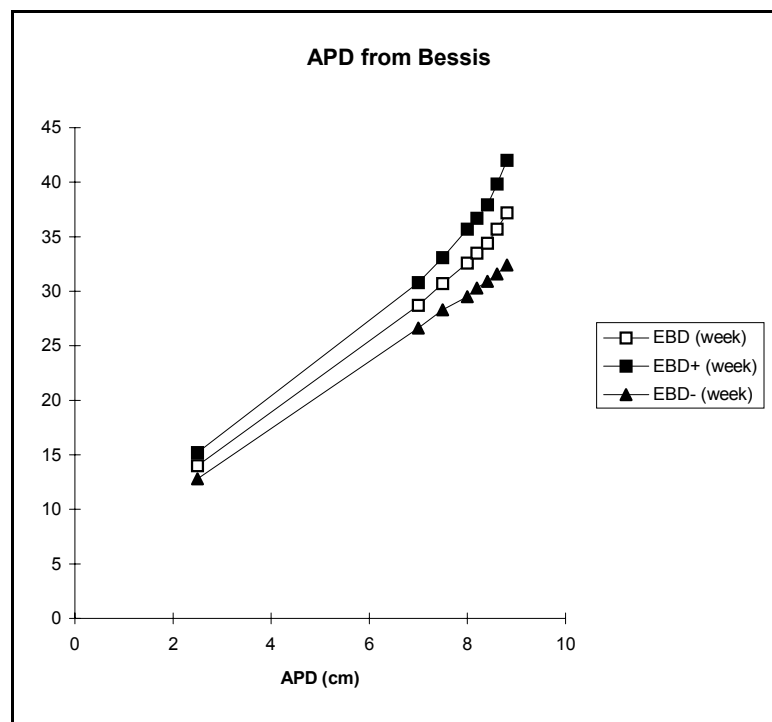

APD (cm)	EBD (week)	+/-
2.5	14	1.2
7	28.7	2.1
7.5	30.7	2.4
8	32.6	3.1
8.2	33.5	3.2
8.4	34.4	3.5
8.6	35.7	4.1
8.8	37.2	4.8

G.7.2.1 Source: The values have been picked on the graphic provided by Dr. Gortchakoff.
 Author Dr. Bessis

G.7.3 APD from Merz

APD (cm)	EBD (week)	+/-
1.9	12.5	1.2
3.1	16	1.2
4.2	19	1.4
5.4	22.5	1.7
6.3	25.5	1.9
7.5	29	2.1
8.4	32	2.4
9.4	35.5	2.7
10.2	38.5	3
10.9	41.5	3.5

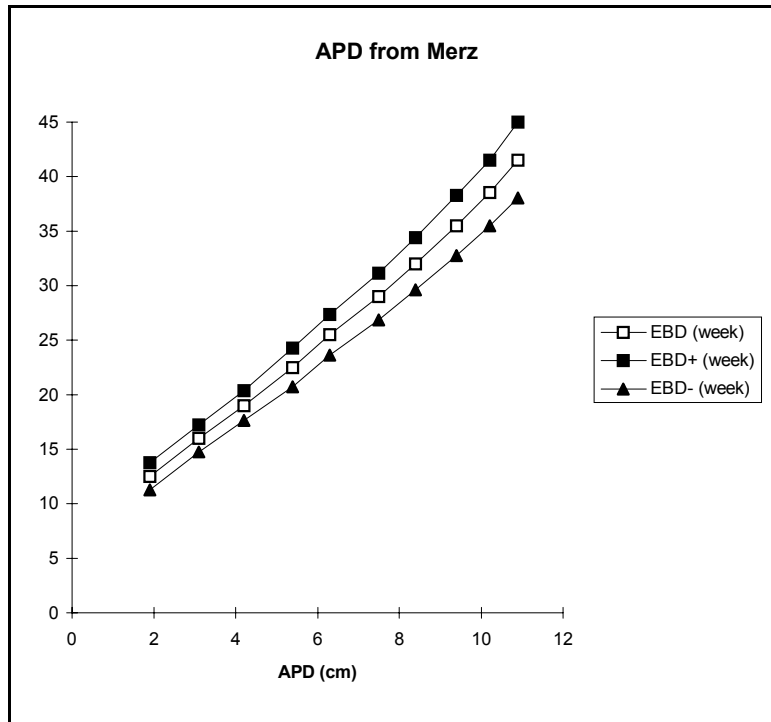

G.7.3.1 Source: *Ultrasound in Gynaecology and Obstetrics Textbook and Atlas*, Thieme Medical Publishers, Inc., New York, 1991.

G.8 Crown Rump Length (CRL)

G.8.1 CRL from Robinson

CRL (cm)	EBD (week)	+/-
0.42	6	0.6
0.88	7	0.7
1.46	8	0.7
2.18	9	0.7
3.03	10	0.7
4.01	11	0.7
5.14	12	0.7
6.39	13	0.7
7.78	14	0.8

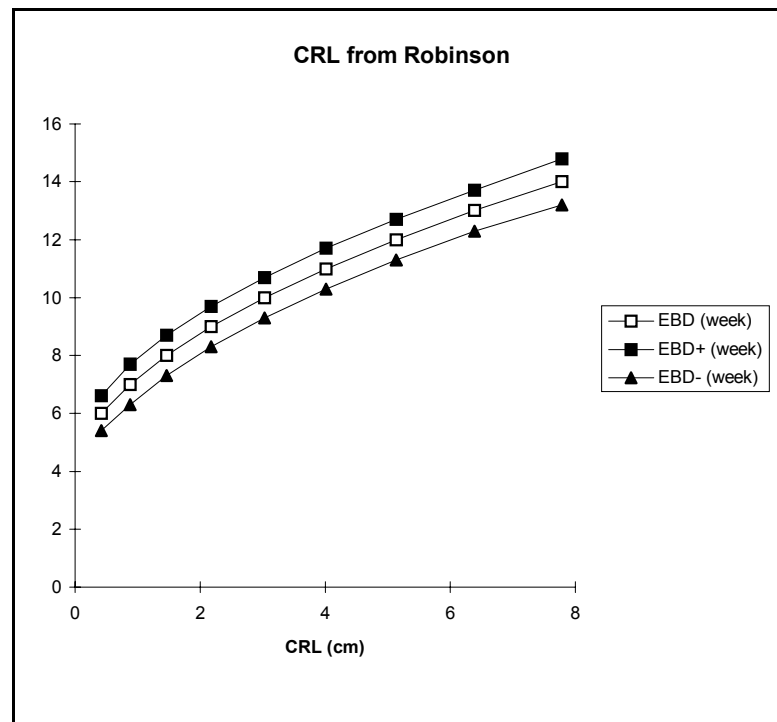

G.8.1.1 Source: The data are those reported by Robinson and Flemming, *Brit. J. Obst. Gyn.* V82, 1975, p. 702-710. (Same as SIGMA 20, see memo Ch. Gähwiler)

Author: Robinson

Sound Velocity: 1540 m/s (Values are scaled from a sound velocity of 1530 m/s as in the publication to 1540 m/s for the table).

Uncertainty: two standard deviation

G.8.2 CRL from Hohler

CRL (cm)	EBD (week)	+/-
0.6	6.3	0.34
1.2	7.6	0.34
2.4	9.3	0.34
3.4	10.4	0.34
4.4	11.4	0.34
5.2	12	0.34
6	12.7	0.34
7.8	14	0.34

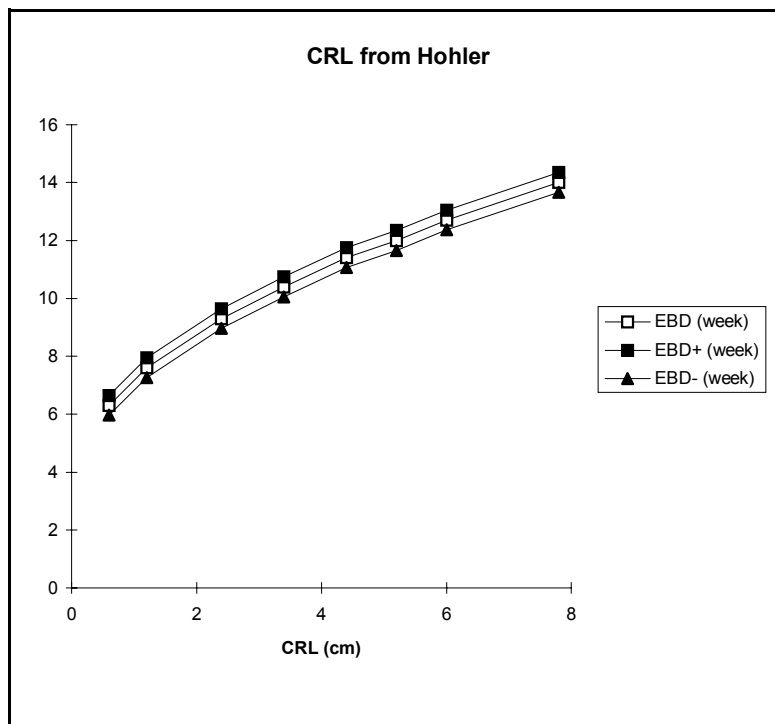

G.8.2.1 Source: Charles W. Hohler; MD. University of Miami School of Medicine (Adapted from Robinson & Fleming, BJ Obs & Gyn. 82, 702, 1975).

G.8.3 CRL from Jeanty

CRL (cm)	EBD (week)	+/-
0.6	6.6	0.7
1.6	8.1	0.7
1.8	8.6	0.7
2.4	9.1	0.7
2.6	9.6	0.7
4.2	11.1	0.7
4.4	11.1	0.7
5.4	12.1	0.7

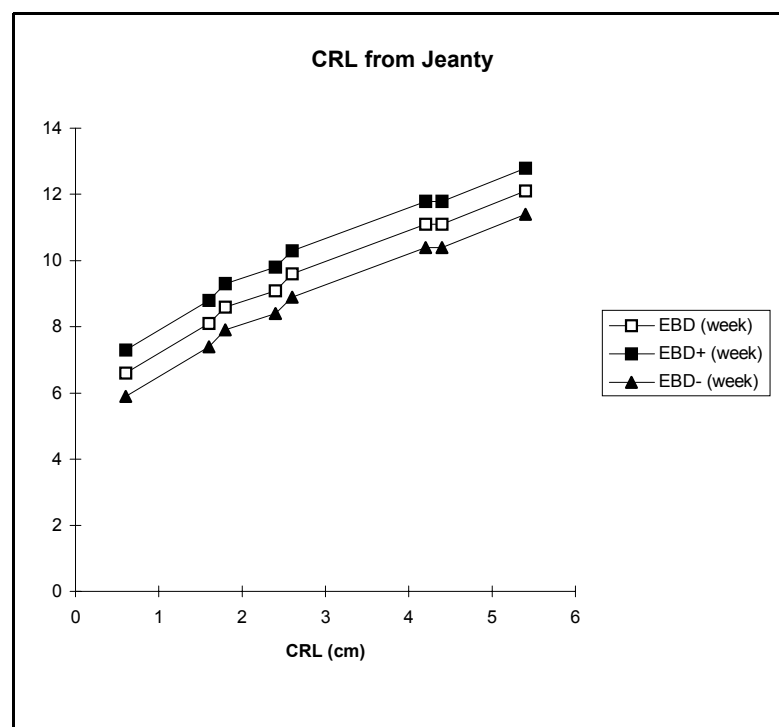

G.8.3.1 Source: Chervenak, F.A.: Jeanty, P., Hobbins, J.C.: Current Status of Fetal Age and Growth Assessment

G.8.4 CRL from Hansmann

CRL (cm)	EBD (week)	+/-
1.3	8	1.5
1.8	9	1.5
2.6	10	1.5
6	13	2
9.7	16	1
12	18	1.5
14	20	2
15	21	2.5
16	22	2.5

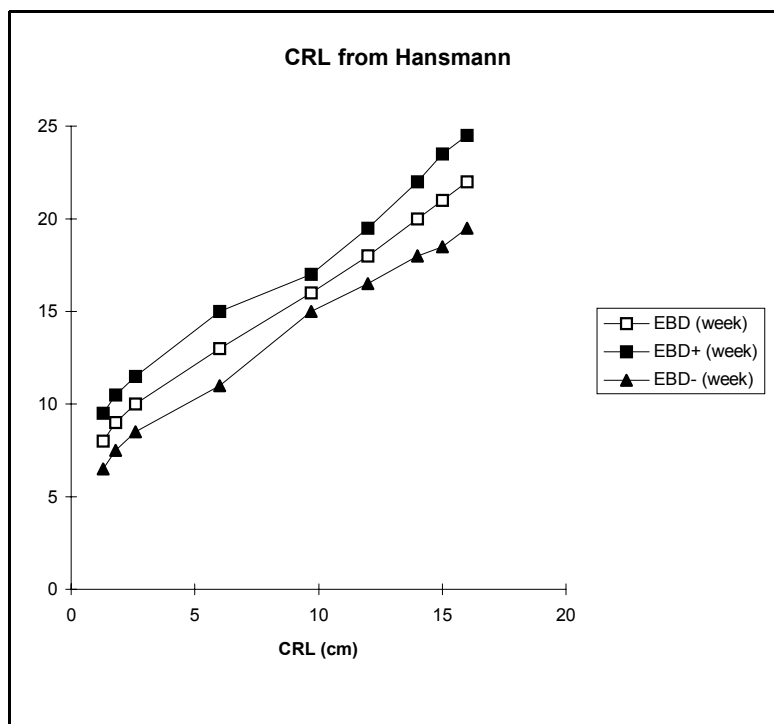

G.8.4.1 Source: Dr. Hansmann, "Ultraschalldiagnostik in Geburtshilfe und Gynäkologie", pages 419 to 421, Springer Verlag, ISBN 3-540-11428-9

G.8.5 CRL from Rempen

CRL (cm)	EBD (week)	+/-
0.2	6	0.8
1.1	7.28	0.8
1.9	8.28	0.8
2.8	9.43	0.8
3.6	10.28	0.8
4.5	11.14	0.8
5.3	11.86	0.8
6.2	12.57	0.8
7	13.14	0.8
7.8	13.71	0.8

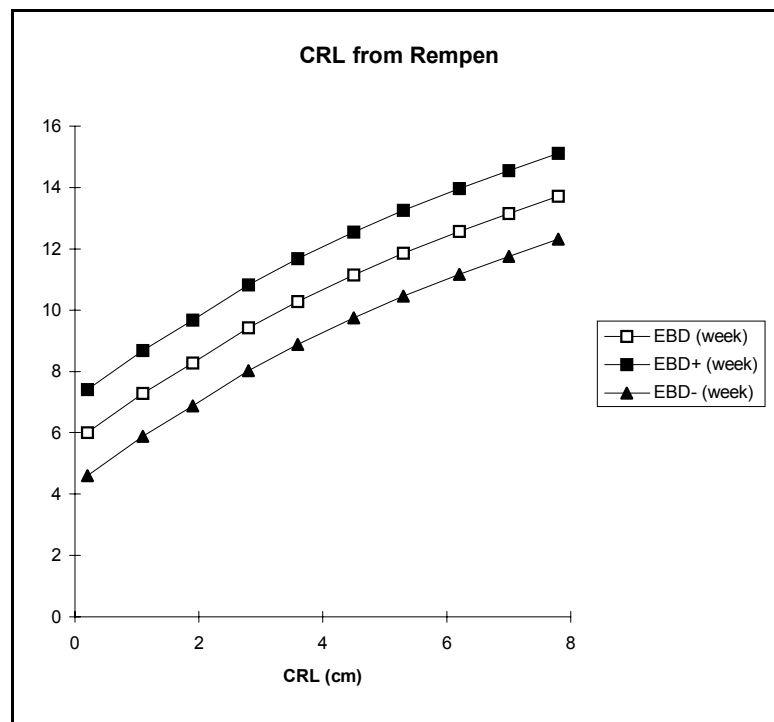

G.9 Gestational Sac (GES)

G.9.1 GES from Ramzin

GES (cm)	EBD (week)	+/-
0.77	5	1.2
5.71	12	1.2

*G.9.1.1 Source: Dr. Ramzin, Basel
Sound Velocity: 1540m/s
Uncertainty: two standard deviation*

G.9.2 GES from Hellmann

GES (cm)	EBD (week)	+/-
0.4	4.7	1
4.7	10.3	1

G.9.2.1 Source: Provided by the marketing: Adapted from Hellmann, I.M.: Am. J. Obstet. Gynecol. 103 : 789, 1969; based on the average sac diameter in three dimensions.

G.9.3 GES from Hansmann

GES (cm)	EBD (week)	+/-
0.7	2.9	1.1
0.9	3.7	1.1
1	4	1.1
1.3	4.3	1.1
1.5	4.7	1.1
2.4	5.4	1.1
2.8	6.3	1.1
3.4	7	1.1

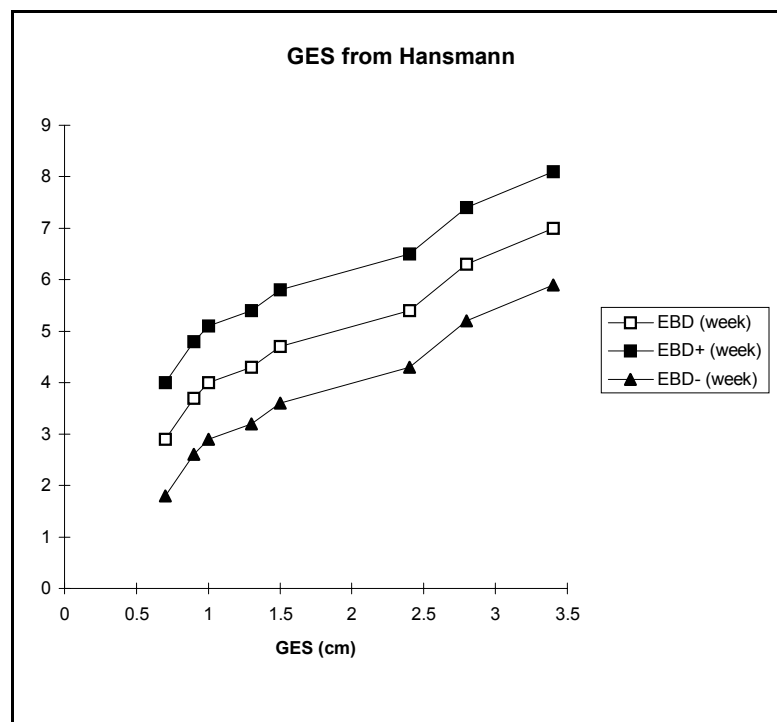

G.9.3.1 Source: Dr. Hansmann, "Ultraschalldiagnostik in Geburtshilfe und Gynäkologie", page 39, Springer Verlag, ISBN 3-540-11428-9

G.10 Abdominal Circumference (AC)

G.10.1 AC from Hadlock

AC (cm)	EBD (week)	+/-
10	15.6	1.9
17.5	22.5	1.9
23	27.3	2
30	34.1	3
36.5	40.8	2.5

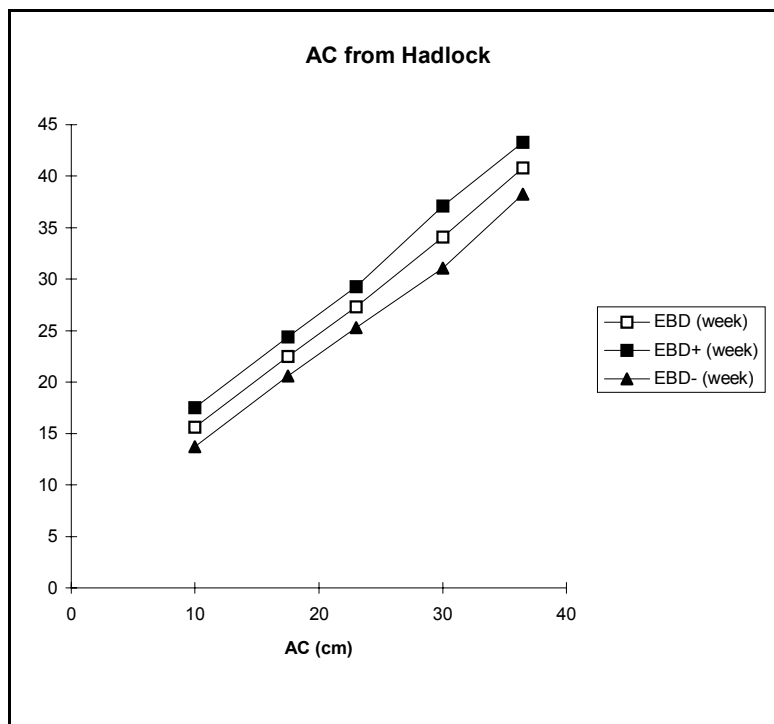

G.10.1.1 Source: F.P. Hadlock; R.L. Deter; R.B. Harrist; S.K. Park. Fetal Abdominal Circumference as a Predictor of Menstrual Age. *Am. J. Roentgenology*. 139:367, 1982.

G.10.2 AC from Merz

AC (cm)	EBD (week)	+/-
6.2	12.5	1.2
10	16	1.2
13.2	19	1.4
17	22.5	1.6
20.2	25.5	1.8
23.7	29	2
26.6	32	2.3
29.8	35.5	2.7
32.3	38.5	2.9
34.3	41.5	3.6

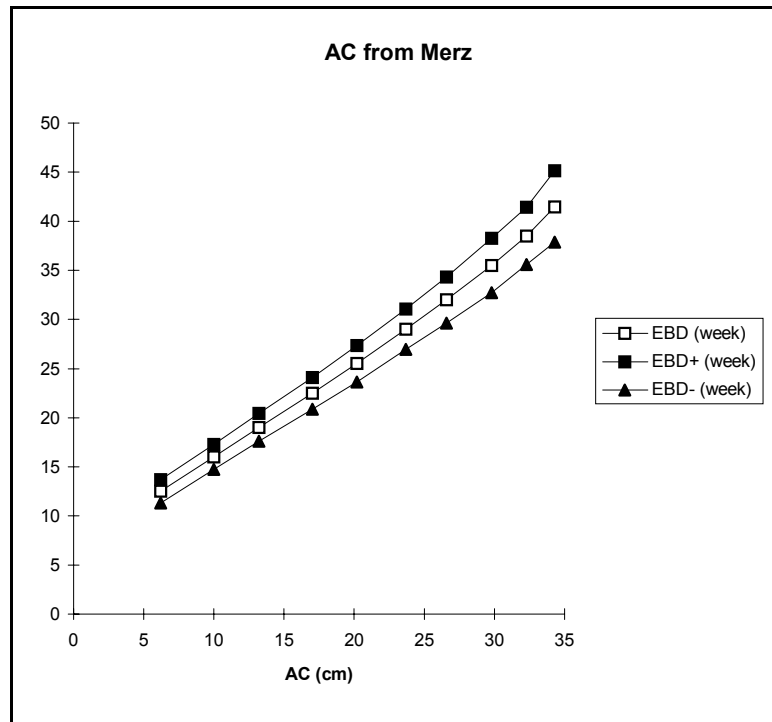

G.10.2.1 Source: *Ultrasound in Gynaecology and Obstetrics Textbook and Atlas*, Thieme Medical Publishers, Inc., New York, 1991.

G.10.3 AC from Lai/Yeo

AC (cm)	EBD (week)	+/-
9.6	15.8	0.8
14.5	20.0	1.0
19.9	25.0	1.2
22.0	27.0	1.4
23.0	28.0	1.5
23.9	29.0	1.4
25.9	31.0	1.7
28.6	34.0	2.0
30.3	36.0	2.1
32.3	38.5	2.5

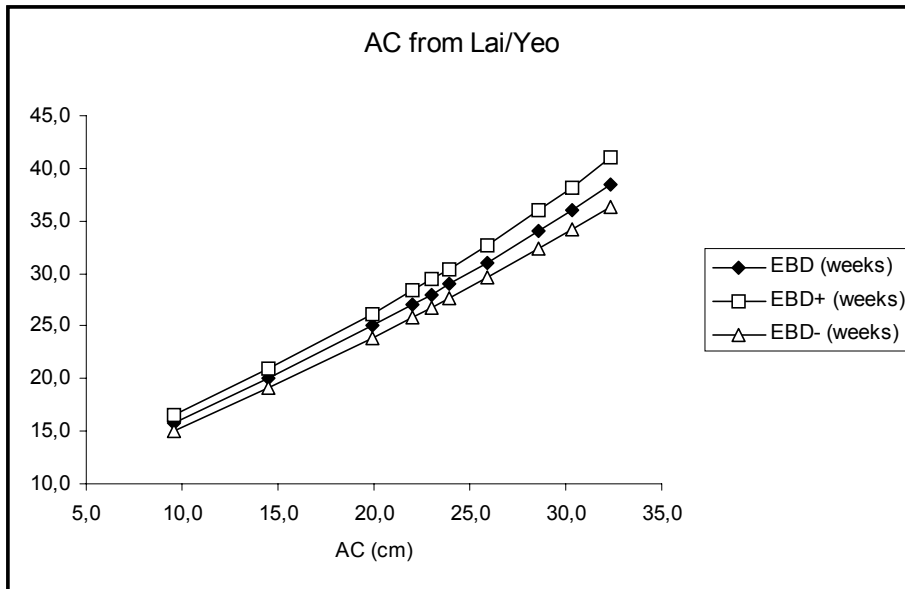

G.10.3.1 Source: F.M. Lai, G.S.H Yeo: Reference Charts of foetal biometry in Asian, Singapore Med J 1995; Vol 36: 628-636

G.11 Head Circumference (HC)

G.11.1 HC from Hadlock

HC (cm)	EBD (week)	+/-
8	13.4	1.3
20	22.1	1.6
26	28	2.3
29	31.6	2.3
32	35.5	2.7
33.5	37.7	3.4
35	40	3.4
36	41.6	3.4

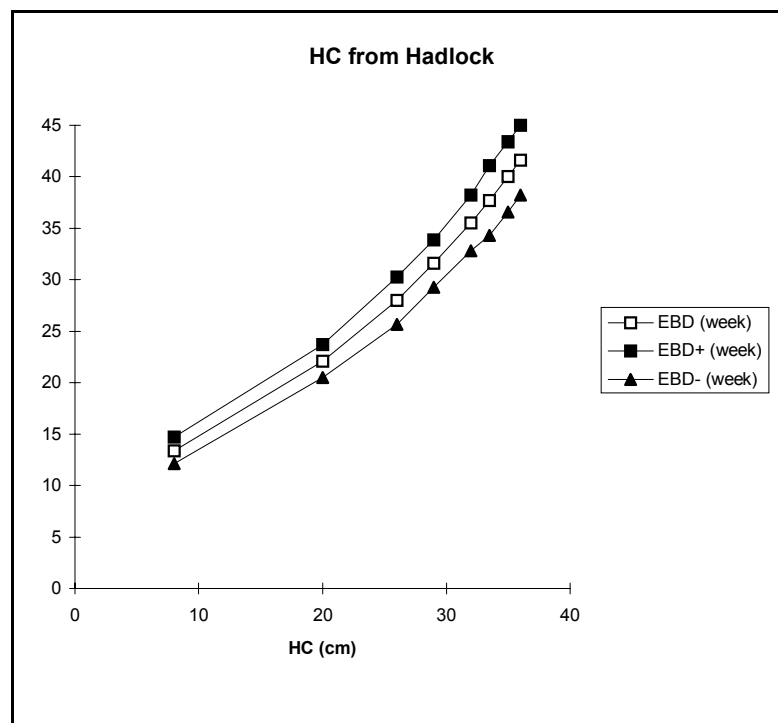

G.11.1.1 Source: F.P. Hadlock; R.L. Deter; R.B. Harrist; S.K. Park. *Fetal Head Circumference: Relation to Menstrual Age. Am. J. Roentgenology. 138:649, 1982*

G.11.2 HC from Merz

HC (cm)	EBD (week)	+/-
9.2	12.5	1.3
13	16	1
16.8	19	1
21.2	22.5	1.2
24.7	25.5	1.3
28.3	29	1.7
30.9	32	2.1
33.2	35.5	3.8
34.5	38.5	3.7
35	41.5	5.8

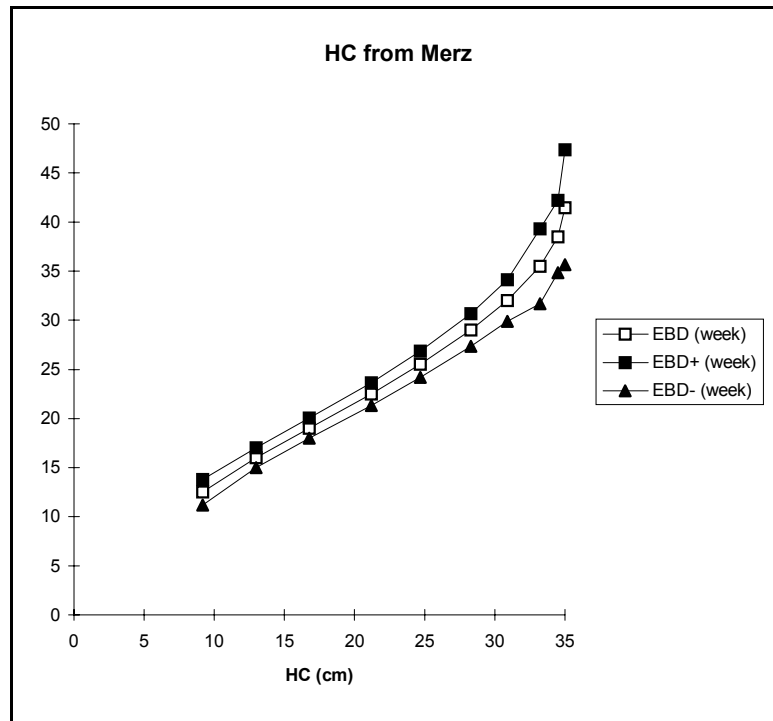

G.11.2.1 Source: *Ultrasound in Gynaecology and Obstetrics Textbook and Atlas*, Thieme Medical Publishers, Inc., New York, 1991.

G.11.3 HC from Lai/Yeo

HC (cm)	EBD (week)	+/-
9.7	14.8	0.8
16.7	20.0	0.9
20.3	23.0	1.1
22.5	25.0	1.1
25.5	28.0	1.3
27.3	30.0	1.6
28.1	31.0	1.7
30.2	34.0	2.2
30.8	35.0	2.5
31.8	37.0	4.0

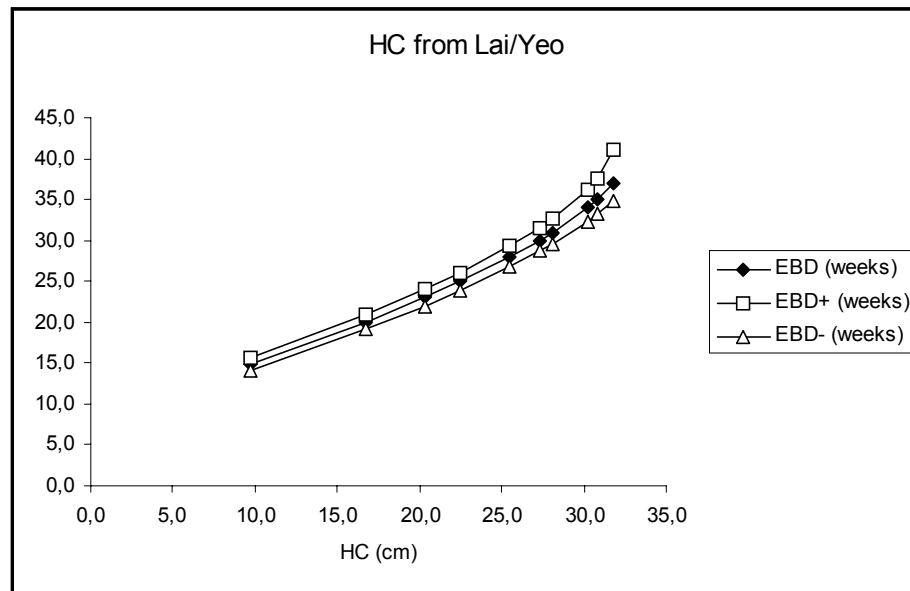

G.11.3.1 Source: F.M. Lai, G.S.H Yeo: Reference Charts of foetal biometry in Asian, Singapore Med J 1995; Vol 36: 628-636

G.12 Binocular Distance (BOD) from Jeanty

BOD (cm)	EBD (week)	+/-
1.5	10.4	0.7
6.5	40.1	2

G.12.0.1 Source: Jeanty, P.; Cantraine, F.; Cousaert, E.; Romero, R.; Hobbins, J.C. *The Binocular Distance: A New Way to Estimate Fetal Age. J Ultrasound Med* 3:241-243, 1984.

G.13 Occipital Frontal Diameter (OFD) from Merz

OFD (cm)	EBD (week)	+/-
3	12.5	1.2
4.3	16	1
5.6	19	1.4
7.1	22.5	1.2
8.2	25.5	1.5
9.4	29	2.2
10.2	32	2.4
11	35.5	3
11.3	38.5	4.5
11.5	41.5	6.5

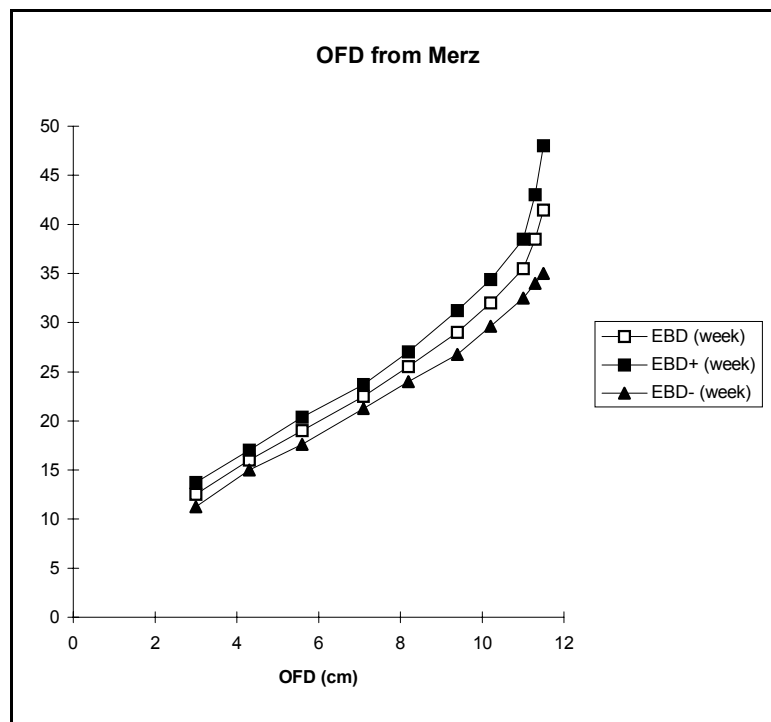

G.13.0.1 Source: *Ultrasound in Gynaecology and Obstetrics Textbook and Atlas*, Thieme Medical Publishers, Inc., New York, 1991.

Appendix H: Radiology Study

H.1 Description

14/03/01 08:30:31

LAB. :
 OPER. :
 NAME :
 EXAM.N:..... SEX:• H:...cm W:...kg AGE: y BSA: m2 HR:...b/mn

ABDO 2D STUDIES

VOLUMES	<i>label1</i>	<i>label2</i>	CARDIAC OUTPUT
Coeff.	<i>coeff1</i>	<i>coeff2</i>	
d1[cm]	_____	_____	Diam[cm] _____
d2[cm]	_____	_____	
d3[cm]	_____	_____	CONTINUITY EQUATION
ÆV[cm3]			Diam1[cm] _____

VOLUMES	<i>label3</i>	<i>label4</i>	
Coeff.	<i>coeff3</i>	<i>coeff4</i>	
d1[cm]	_____	_____	
d2[cm]	_____	_____	
d3[cm]	_____	_____	
ÆV[cm3]			

PAEDIATRICS STUDIES

HIP ANGLES

Alpha [dg]	_____	Beta [dg]	_____
ÆType		ÆType	

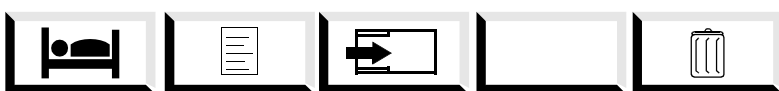

a) Volumes

- Volume label : user-defined (*label1, label2, label3, label4*)
- Coeff. : user-defined (*coeff1, coeff2, coeff3, coeff4*)
- d1 : Distance 1 in cm
- d2 : Distance 2 in cm
- d3 : Distance 3 in cm
- ÆV : Volume in cm3

Volume label and related coefficient can be defined by user.
 By default, the system uses the following values:

	Default Name	Default Coeff.
<i>label1</i>	Ellipse	0.523
<i>label2</i>	Ellipse	0.523
<i>label3</i>	Thyroid	0.479
<i>label4</i>	Thyroid	0.479

b) Cardiac Output

Diam : Diameter of the vessel in cm

c) Continuity Equations

Diam1 : Diameter 1 in cm

d) Hip Angles

Alpha : Alpha angle in degrees
 ÆType : Type of the Alpha angle
 Beta : Beta Angle in degrees
 ÆType : Type of the Beta angle

This measurement is made in 3 steps:

- The Baseline is a line drawn from the ilium to the epiphysis.
- The Alphaline is a line drawn from the triradiate cartilage to the lateral aspect of the bony acetabulum.
- The Betaline is a line drawn from the lateral aspect of the labrum to the bony margin of the acetabulum.

H.2 Equations

• **Volumes in cm³**

$$V = D \cdot Coeff \cdot D1 \cdot D2 \cdot D3$$

Coeff : User modifiable coefficient
 D1 : Distance 1 in centimetres
 D2 : Distance 2 in centimetres
 D3 : Distance 3 in centimetres
 V : Volume in cm³

• **Ellipsoid Volumes in cm³ (by default)**

$$V = D^{4/3} \cdot \pi \cdot \frac{D1 \cdot D2 \cdot D3}{8}$$

D1 : Distance 1 in centimetres
 D2 : Distance 2 in centimetres
 D3 : Distance 3 in centimetres
 V : Volume in cm³

- **Thyroid volumes in cm³ (by default)**

$$V = 0,479 \cdot D1 \cdot D2 \cdot D3$$

D1 : Distance 1 in centimetres
 D2 : Distance 2 in centimetres
 D3 : Distance 3 in centimetres
 V : Volume in cm³

Reference:

W. Wiedermann, K. Wurster, H.Czempel :
 "Sonographie und Szintigraphie der Schilddrüse"

- **HIP angles**

- **Alpha angle**

The Alpha Angle is the angle formed by the Baseline and the Alphaline

Type = 6 if Alpha >= 5

Type = 7 if Alpha >= 98 and Alpha <= 60

Type = 8 if Alpha < 43

###

Type : #Type of the Alpha angle

- **Beta angle :**

The Beta Angle is the angle formed by the Baseline and the Betaline.

Type = 6 if Beta < <<

Type = 7 if Beta >= 55 and Beta <= 77

Type = 8 if Beta > 77

###

Type## : #Type of the Beta Angle

This page is intentionally left blank

Appendix I: Measurement Interface

A report sheet is a collection of fields ordered by function (Mitral Valve, Pulmonary Artery, ...) - see screens description above. The user can fill the report in two ways:

- the report being displayed, the user activates a measurement by clicking on a field.
- after having done a measurement, the user can insert it in the report.

I.1 Doing a Measurement from Report

Press the REPORT key to display a report sheet on screen.

I.1.1 Operating Mode

To make a measurement, the user selects a main field by pointing it with the report cursor. If the measurement is possible to do, the pointed field highlights. To start the related measurement, the user clicks on the CURSOR SET keyboard key. Then, the ultrasound screen appears, and the user starts the measurement. Now, the user can:

- move the trackball and finish the measurement; the report sheet is displayed again and all the related fields are updated (main field, results fields and computed fields if all data are available)
- abort the measurement and return to the report screen: he presses on the ESCAPE keyboard key, no field is modified.
- abort the measurement, exit the report and return to a live image: he presses on the FREEZE key, no field is modified.

When is a measurement possible to do?

Each measurement is associated to a specific mode. For example: 2D for area, TM for time, SP for velocity integral. A measurement is possible to do if its related mode was displayed at screen just before the user entered the report. The table below summarizes all the possible states:

System mode	Authorized measurements	Comments
2D or CFM	2D measurements	
Double 2D	2D measurements	
Quad 2D	2D measurements	
Zoom	2D measurements	
2D/TM or CFM/TM	2D measurements	if TM is active, switch on 2D pad
	TM measurements	if 2D is active, switch on TM pad
TM	TM measurements	
2D/SP	2D measurements	if SP is active, switch on 2D pad
	SP measurements	if 2D is active, switch on SP pad
2Di/SP or CFMi/SP	2D measurements	if SP is active, switch on 2D pad
	SP measurements	if 2D is active, switch on SP pad

I.1.2 Special Cases

I.1.2.1 Cardiac Output Diameter

This field duplicates the Cardiac Output Diameter field of the vascular study sheet.

When this field is modified, the value displayed in the vascular page is automatically updated and conversely.

I.1.2.2 Continuity Equation Diameter

This field duplicates the Continuity Equation Diameter field of the vascular study sheet.

When this field is modified, the value displayed in the vascular page is automatically updated and conversely.

I.1.2.3 Hip Angle

The hip angle is computed either from the Alpha or the Beta field.

Once a field is selected, the sigma switches to the frozen ultrasound image and the angle measurement starts. This measurement is made in three steps:

step 1 : the user places his baseline

step 2 : the user places his alpha line

step 3 : the user places his betaline

The hip angle is then computed and the ultrasound image remains displayed. Here, the user can correct the computed alpha and/or beta angles. This correction is needful to balance careless mistakes. In fact, there are two values to define an angle between two lines.

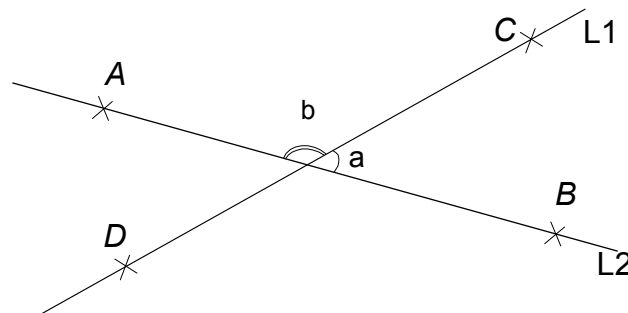

In the above example, a and b defines the same angle formed by L1 and L2. The computed angle depends on the way the lines L1 and L2 are drawn: if drawing L1 from C to D and L2 from B to A gives the angle b, then drawing L1 from C to D and L2 from A to B will gives the angle a.

Notice that the following relation is always right:

$$a = p - b$$

b is the complement of a to p

The following menu will be displayed while processing the hip angle measurement.



If the user remarks the Alpha angle is bad because points are set in reverse order, then he presses on the softkey1 "Complement Alpha" and adjusts the Alpha angle.

If the user remarks the Beta angle is bad because points are set in reverse order, then he presses on the softkey2 “*Complement Beta*” and adjusts the Beta angle.

When all the angles are correct, he presses on the F5 “*Finish Meas*” or on the <CURSOR_SET> key to return to the biometry screen.

1.1.2.4 Left Ventricle Study

- When the TM-measurement menu is displayed, both full and abbreviate version of the left ventricle measurement are available.

When the user activates a TM-measurement on the left ventricle from the cardio report sheet, the measurement is done in either abbreviate or full version, according to user preference. User preferences are defined in the preference menu.

1.1.2.5 Automatic Integral

Velocity Integral can be made either in automatic or in manual mode. The default mode is defined by user in a preference menu.

In automatic mode, the Vmax or the Vmean profile will be chosen, according to the current measurement, as described hereunder:

Velocity Integral	Profile Type
MVI	VMean
PI	VMax
VTI	VMax

Table 7-1:

While measurement is in progress, the user can switch between manual or automatic mode. Manual mode is only available with Vmax.

1.1.2.6 PI/RI Measurement

Computing the Pulsatility Index updates also the Resistance Index.

But, the Resistance Index can be computed separately.

1.1.2.7 Area Measurements

An area can be computed either with an ellipse or an area measurement, according to user’s preferences.

User preferences are defined in the preference menu.

1.2 Importing Measurements in Report

The user can do a measurement from the measurement menu and can insert the last measurement in the report sheet.

I.2.1 Operating Mode

After having done a measurement from the measurement menu, the user can insert it in the report. The user selects the suitable report sheet and moves the trackball cursor on the main fields of interest. When a relevant field is pointed, it highlights to indicate the insertion is possible. The user then presses on the CURSOR SET key to insert the last measurement. All the related results and computed fields are automatically updated if all data are available.

Note: to activate the import mode, the measurement menu must be displayed before entering the report.

I.2.2 Special Cases

I.2.2.1 Ratio Measurement

All ratios measurement can be inserted in the corresponding fields (e.g. a distance/ratio can be inserted in a distance field, a speed/ratio can be inserted in a speed field, ...)

I.2.2.2 PI and RI Measurement

A PI measurement can be inserted in the PI fields. The RI value is updated.

A RI measurement can be inserted in the RI field only.

I.2.2.3 Speed and Frequency

A speed measurement can be inserted in a frequency field and conversely.

A speed/ratio measurement can be inserted in a speed or in a frequency field.

I.2.2.4 Heart Rate and Time

A time measurement can be inserted in a heart rate field and conversely.

A time/ratio measurement can be inserted in a time or in a heart rate field.

I.2.2.5 Area Measurement

Both area and ellipse measurement can be inserted in the relevant report fields.

An Area/ratio measurement can be inserted in both area and ellipse fields.

I.2.2.6 Left Ventricle Study

Both abbreviate and full version of the left ventricle TM-measurement can be inserted in the relevant report fields. Only the available data will be displayed for the abbreviate measurement.

I.2.2.7 Automatic Integral

Both manual and automatic integral can be inserted in the relevant report fields.

I.2.2.8 Hip Angle

This measurement cannot be imported because it is not available in the measurement menu.

Appendix J: Print Preview

J.1 Edit the Printable Report

To edit the printable report, the user must press on the  icon.

The print preview is displayed according to the following template:

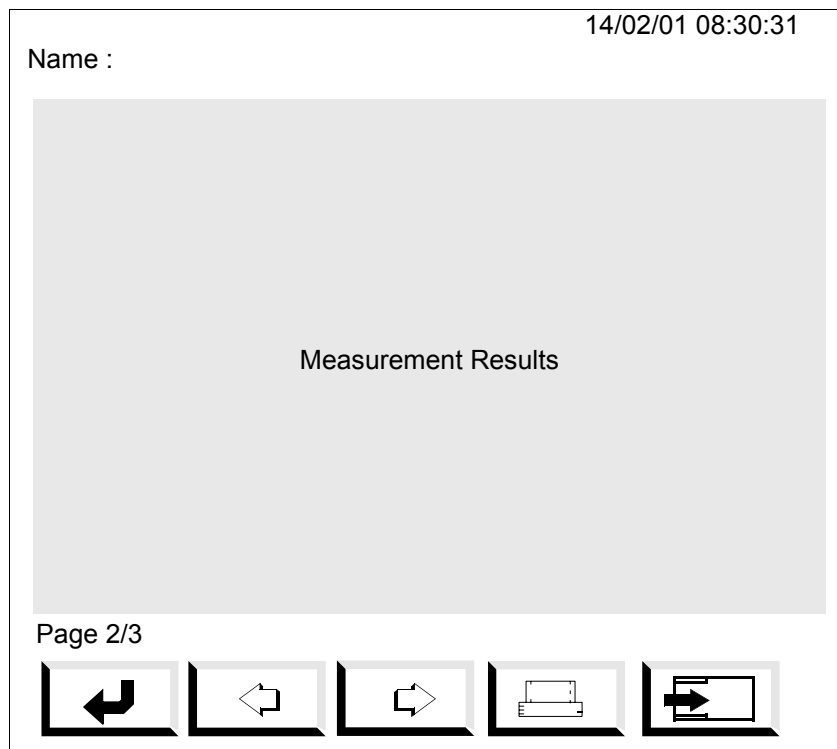

Like for the measurement page, the report page is divided in three parts :

- At the top of the page, the patient name is displayed.
- The second part contains the results of the different calculations which has been done by the user. These results are sorted by medical application first and by measurement group then.

For example, when the user has made measurement in different medical application, he will find first the results of the vascular study measurement, then the abdominal study measurements, The patient and laboratory information are always displayed at the end of the report preview.

The following figure give an example of a print preview screen.

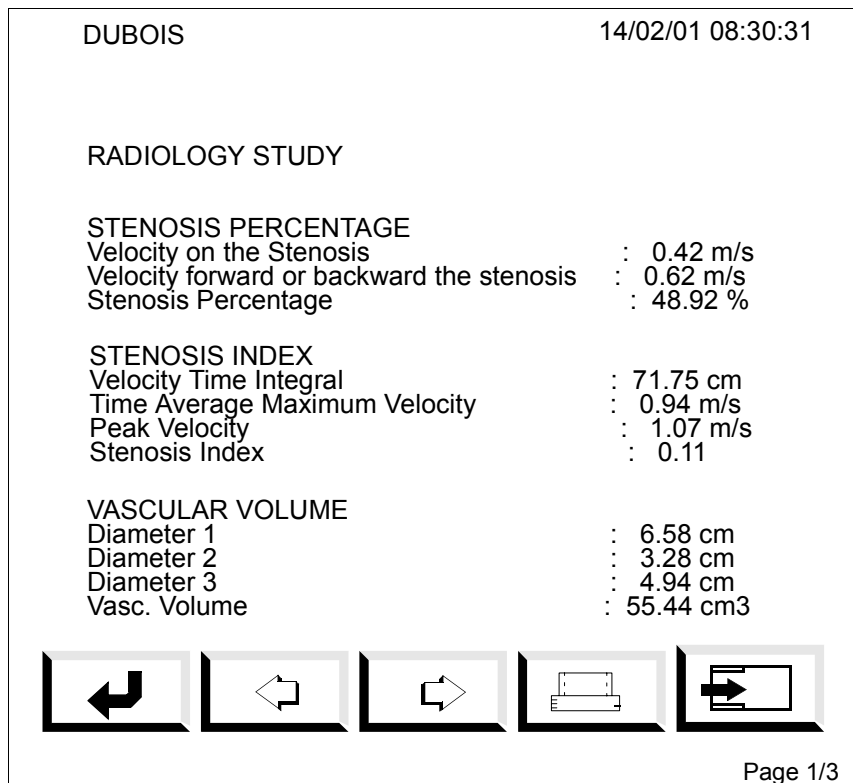

- The print preview will be modified according to printout improvements.
- The third part contains the different tools icons. See *Appendix B, "Report Menu"*, on page 7-5 for more information.

J.2 Print the Report on an External Printer

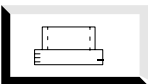
The user can here print the whole study on an external printer. To do this, he must press the  icon.

J.3 Save the Report on a Flashcard

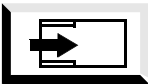
The user can store the report in a text file on the flashcard. To do this, the KIPRISM option must be enabled and he must press the  icon.

Appendix K: KIPRISM / SonoWin[®] Basic Conversion Tables

K.1 Overview

This section describes the correspondance between the SIGMA measurement values and the SonoWin[®] Basic ones. These correspondances are shown in tables sorted by medical application and have to be read as shown below:

Description	SIGMA		SonoWin [®]		Chapter
	LALd	cm	LVLd	mm	
Long Axis Length at diastole	LALd	cm	LVLd	mm	Card 2D LV Single Plane

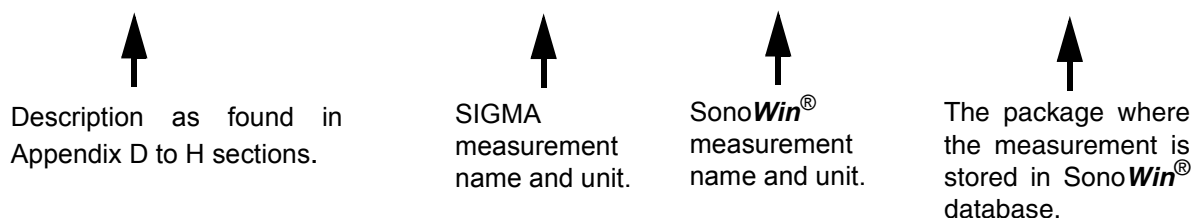

K.2 Cardiology Measurements

K.2.1 Left Ventricle study

K.2.1.1 2D measures (Single Plane)

Description	SIGMA		SonoWin [®]		Chapter
	LALd	cm	LVLd	mm	
Long Axis Length at diastole	LALd	cm	LVLd	mm	Card 2D LV Single Plane
Long Axis Area at diastole	LAAAd	cm ²	LVALD	cm ²	Card 2D LV Single Plane
Long Axis Length at systole	LALs	cm	LVLs	mm	Card 2D LV Single Plane
Long Axis Area at systole	LAAAs	cm ²	LVALS	cm ²	Card 2D LV Single Plane
Diastolic Volume	VOLd	cm ³	EDV	ml	Card 2D LV Simpson's Rule
Systolic Volume	VOLs	cm ³	ESV	ml	Card 2D LV Simpson's Rule
Ejection Fraction	EF	%	EF		Card 2D LV Simpson's Rule
Stroke Volume	SV	ml	SV	ml	Card 2D LV Single Plane
Stroke Index	SI	ml	SI	ml/m ²	Card 2D LV Single Plane
Cardiac Output	CO	l/min	CO	l/min	Card 2D LV Single Plane
Cardiac Index	CI	l/min/m ²	CI	l/min/m ²	Card 2D LV Single Plane

K.2.1.2 2D measures (Simpson)

Description	SIGMA		SonoWin®		Chapter
Short Axis Area 1 at Diastole	SAA1d	cm ²	LVAMD	cm ²	Card 2D LV Biplane
Short Axis Area 2 at Diastole	SAA2d	cm ²	LVAPD	cm ²	Card 2D LV Simpson's Rule
Long Axis Length at Diastole	LALd	cm	LVLD	mm	Card 2D LV Simpson's Rule
Short Axis Area 1 at Systole	SAA1s	cm ²	LVAMS	cm ²	Card 2D LV Biplane
Short Axis Area 2 at Systole	SAA2s	cm ²	LVAPS	cm ²	Card 2D LV Simpson's Rule
Long Axis Length at Systole	LALs	cm	LVLS	mm	Card 2D LV Simpson's Rule
Diastolic Volume	VOLd	cm ³	EDV	ml	Card 2D LV Biplane
Systolic Volume	VOLs	cm ³	ESV	ml	Card 2D LV Biplane
Ejection Fraction	EF	%	EF	-	Card 2D LV Biplane
Cardiac Output	CO	l/min	CO	l/min	Card 2D LV Simpson's Rule
Cardiac Index	CI	l/min/m ²	CI	l/min/m ²	Card 2D LV Simpson's Rule
Stroke Volume	SV	ml	SV	ml	Card 2D LV Biplane
Stroke Index	SI	ml/m ²	SI	ml/m ²	Card 2D LV Biplane

K.2.1.3 TM measures (Teichholtz)

Description	SIGMA		SonoWin®		Chapter
Right Ventricle Diameter at diastole	RVDd	cm	RVDD	mm	Card M LV Teichholtz
Inter Ventricular Septal Thickness at diastole	IVSd	cm	IVSTS	mm	Card M LV Teichholtz
Left Ventricle Diameter at diastole	LVDd	cm	LVIDD	mm	Card M LV Teichholtz
Posterior Left Ventricular Wall at diastole	PLVWd	cm	LVPWD	mm	Card M LV Teichholtz
Inter Ventricular Septal Thickness at systole	IVSs	cm	IVSTS	mm	Card M LV Teichholtz
Left Ventricle Diameter at systole	LVDs	cm	LVIDS	mm	Card M LV Teichholtz
Posterior Left Ventricular Wall at systole	PLVWs	cm	LVPWS	mm	Card M LV Teichholtz
Left Ventricle Ejection Time	LVET	sec	ET	ms	Card M LV Teichholtz
Diastolic Volume (Teichholz formula)	VOLd	cm ³	EDV	ml	Card M LV Teichholtz
Systolic Volume (Teichholz formula)	VOLs	cm ³	ESV	ml	Card M LV Teichholtz
Shortening Fraction	SF	%	FS	-	Card M LV Teichholtz
Left Ventricle Mass	LVM	gr	LV_mass	g	Card M LV Teichholtz
Left Ventricle Mass Index	LVMI	gr/m ²	LV_massI	g/m ²	Card M LV Teichholtz
Velocity of Circumferential Fibre Shortening	VCF	circ/sec	MVCF	circ/s	Card M LV Teichholtz
Ejection Fraction	EF	%	EF	-	Card M LV Teichholtz
Stroke Volume	SV	ml	SV	ml	Card M LV Teichholtz
Stroke Volume Index	SI	ml/m ²	SI	ml/m ²	Card M LV Teichholtz
Cardiac Output	CO	l/min	CO	l/min	Card M LV Teichholtz
Cardiac Output Index	CI	l/min/m ²	CI	l/min/m ²	Card M LV Teichholtz
Ratio Left Ventricular Wall (diastole) on Left Ventricle Radius (diastole)	H/R	-	LVPWD/LVIDD	-	Card M LV Teichholtz

K.2.1.4 Heart rate (TM and SP measurement)

Description	SIGMA		SonoWin®		Chapter
Heart rate measured on Left Ventricle	HR	bpm	HR	bpm	Card 2D LV Simpson's Rule

K.2.2 Mitral Valve page

K.2.2.1 2D measures

Description	SIGMA		SonoWin®		Chapter
Mitral Valve Diameter	MVD	cm	DIAM	mm	Card D Mitral Value
Mitral Valve Area	MVA	cm ²	VA1	mm ²	Card D Mitral Value

K.2.2.2 TM measures

Description	SIGMA		SonoWin®		Chapter
Slope between E- and F-waves	EFsl	cm/s	EFSLP	mm/s	Card M MV and Aorta
Distance from E-wave to septum	ESd	cm	EIVS_d	mm	Card M MV and Aorta

K.2.2.3 SP measures

Description	SIGMA		SonoWin®		Chapter
Velocity Time Integral	VTI	cm	VTI	m	Card D Mitral Valve
(VTI) Peak Velocity	PkV	m/s	Vpeak_calc	m/s	Card D Mitral Valve
(VTI) Peak Gradient	PkG	mmHg	peakPG	mmHg	Card D Mitral Valve
(VTI) Mean Gradient	MnG	mmHg	meanPG	mmHg	Card D Mitral Valve
Peak Velocity for the E-wave	PkVE	m/s	E VEL	m/s	Card D Mitral Valve
Peak Velocity for the A-wave	PkVA	m/s	A VEL	m/s	Card D Mitral Valve
IsoVolumetric Relaxation Time	IVRT	sec	IRT	ms	Card D Mitral Valve
Ratio Peak Velocity E-wave on Peak Velocity A-wave (PkVE/PkVA)	E/A	-	E/A	-	Card D Mitral Valve
Stroke Volume	SV	ml	SV	ml	Card D Mitral Valve
Stroke Volume Index	SI	m ²	SI	ml/m ²	Card D Mitral Valve
Cardiac Output	CO	l/min	CO	l/min	Card D Mitral Valve
Cardiac Output Index	CI	l/min/m ²	CI	l/min/m ²	Card D Mitral Valve

K.2.2.4 Heart rate (TM or SP measurement)

Description	SIGMA		SonoWin®		Chapter
Patient heart rate in beats per minutes on mitral valve	HR	bpm	HR	bpm	Card D Mitral Valve

K.2.2.5 Mitral Valve Effective Opening Area

Description	SIGMA		SonoWin®		Chapter
Sub Aortic Diameter	SAD	cm	DIAM	mm	Card D Mitral Valve
Area computed from DiamAOV	SAA	cm ²	VA2	mm ²	Card D Mitral Valve
Sub Aortic Velocity Time Integral	VTIaov	cm	VTI11	m	Card D Mitral Valve
Velocity Time Integral at Mitral Valve	VTImv	cm	VTI12	m	Card D Mitral Valve
Mitral Valve EOA computed from VTIaov and VTImiv	EOA	cm ²	MVA2	mm ²	Card D Mitral Valve
Pressure Half Time	PHT	msec	PHT	ms	Card D Mitral Valve
Peak Velocity for E-wave	PkVE	m/s	Vpeak1	m/s	Card D Mitral Valve
Valve Area computed from Pressure Half Time	EOA	cm ²	MVA	cm ²	Card D Mitral Valve

K.2.3 Aortic Valve

K.2.3.1 2D study

Description	SIGMA		SonoWin®		Chapter
Aortic Valve Diameter	AVD	cm	DIAM	mm	Card D Mitral Valve
Aortic Valve Area	AVA	cm ²	MVA	cm ²	Card D Mitral Valve

K.2.3.2 SP study

Description	SIGMA		SonoWin®		Chapter
Velocity Time Integral	VTI	cm	VTI	m	Card D Aortic Valve
(VTI) Peak Velocity	PkV	m/s	Vpeak_calc	m/s	Card D Aortic Valve
(VTI) Peak Gradient	PkG	mmHg	peakPG_calc	mmHg	Card D Aortic Valve
(VTI) Mean Gradient	MnG	mmHg	meanPC_calc	mmHg	Card D Aortic Valve
Pressure Half Time	PHT	msec	PHT	ms	Card D Aortic Valve
Left Ventricle Pre Ejection Period	LVPEP	sec	PEP	ms	Card M MV and Aorta
Stroke Volume	SV	ml	SV	ml	Card D Aortic Valve
Stroke Volume Index	SI	ml/m ²	SI	ml/m ²	Card D Aortic Valve
Cardiac Output	CO	l/min	CO	l/min	Card D Aortic Valve
Cardiac Output Index	CI	l/min/m ²	CI	l/min/m ²	Card D Aortic Valve

K.2.3.3 TM study

Description	SIGMA		SonoWin®		Chapter
End diastolic Aortic Root diameter	AoD	cm	AOD	mm	Card M MV and Aorta
Left Atrial end systolic diameter	LAD	cm	LAD	mm	Card M MV and Aorta
Aortic Valve Opening	AVO	cm	AVD	mm	Card M MV and Aorta
Left Ventricle Ejection Time	LVET	sec	ET	ms	Card M MV and Aorta
Left Ventricle Pre-Ejection Period	LVPEP	sec	PEP	ms	Card M MV and Aorta
Ratio Left Atrial, Aortic Root Diameter	LAD/AoD	-	LA/AO	-	Card M MV and Aorta

Description	SIGMA		SonoWin®		Chapter
Ratio Pre Ejection Period, Ejection Time	LVPEP/ LVET	-	PEP/ET	-	Card M MV and Aorta

K.2.3.4 Effective Opening Area

Description	SIGMA		SonoWin®		Chapter
Left Ventricle Output Trunk Diameter	LVOTD	cm	LVOT	mm	Card D Aortic Valve
Area computed from Dlvot	LVOTA	cm ²	LVOT_AREA	cm ²	Card D Aortic Valve
Velocity Time Integral at Left Ventricle Output Trunk	VTI _{lvot}	cm	VTI1	m	Card D Aortic Valve
Velocity Time Integral at Aortic Valve	VTI _{ao}	cm	VTI2	m	Card D Aortic Valve
Effective Opening Area of the Aortic Valve	EOA	cm ²	AREA_VTI12	cm ²	Card D Aortic Valve
Velocity at Aortic Valve	V _{ao}	m/sec	V1	m/s	Card D Aortic Valve
Velocity at Left Ventricle Output Trunk	V _{lvot}	m/sec	V2	m/s	Card D Aortic Valve
Effective Opening Area of the Aortic Valve	EOA	cm ²	AREA_V12	cm ²	Card D Aortic Valve

K.2.3.5 Left Ventricle Output Trunk

- 2D study:

Description	SIGMA		SonoWin®		Chapter
LVOT Diameter	LVOTD	cm	OT_D	mm	Card D Aortic Valve
LVOT Area	LVOTA	cm ²	OT_AREA	cm ²	Card D Aortic Valve

- SP study:

Description	SIGMA		SonoWin®		Chapter
Velocity Time Integral	VTI	cm	VTI	m	Card D Aortic Valve
Peak Velocity	PkV	m/s	V _{max}	m/s	Card D Aortic Valve
Peak Gradient	PkG	mmHg	peakPG	mmHg	Card D Aortic Valve
Mean Gradient	MnG	mmHg	meanPG	mmHg	Card D Aortic Valve
Stroke Volume	SV	ml	SV	ml	Card D Aortic Valve
Stroke Volume Index	SI	ml/m ²	SI	ml/m ²	Card D Aortic Valve
Cardiac Output	CO	l/min	CO	l/min	Card D Aortic Valve
Cardiac Output Index	CI	l/min/m ²	CI	l/min/m ²	Card D Aortic Valve

K.2.3.6 Descending Aorta (SP measurement)

Description	SIGMA		SonoWin®		Chapter
Velocity Time Integral at Systole	VTI _s	cm	AOdesc_VTI_s	m	Card D Aortic Valve
Velocity Time Integral at Diastole	VTI _d	cm	AOdesc_VTI_d	m	Card D Aortic Valve
Ratio VTI Diastole, VTI Systole	VTI _d /VTI _s	-	VTI_d/VTI_s	-	Card D Aortic Valve

K.2.3.7 Heart Rate (TM or SP measurement)

Description	SIGMA		SonoWin®		Chapter
Heart Rate on aortic valve	HR	bpm	HR	bpm	Card D Aortic Valve

K.2.4 Right Ventricle study

K.2.4.1 Pulmonic Valve

- 2D measures:

Description	SIGMA		SonoWin®		Chapter
Pulmonary Artery Diameter	PAD	cm	PAD	mm	Card D Pulmonic Valve

- SP measures:

Description	SIGMA		SonoWin®		Chapter
Velocity Time Integral	VTI	cm	VTI	m	Card D Pulmonic Valve
Peak Velocity	PkV	m/s	Vpeak_calc	m/s	Card D Pulmonic Valve
Peak Gradient	PkG	mmHg	peakPG_calc	mmHg	Card D Pulmonic Valve
Mean Gradient	MnG	mmHg	meanPG_calc	mmHg	Card D Pulmonic Valve
Right Ventricle Pre Ejection Period	RVPEP	sec	PEP	ms	Card D Pulmonic Valve
Stroke Volume	SV	ml	SV	ml	Card D Pulmonic Valve
Stroke Volume Index	SI	ml/m2	SI	ml/m2	Card D Pulmonic Valve
Cardiac Output	CO	l/min	CO	l/min	Card D Pulmonic Valve
Cardiac Output Index	CI	l/min/m2	CI	l/min/m2	Card D Pulmonic Valve

K.2.4.2 Tricuspid Valve

- TM measures:

Description	SIGMA		SonoWin®		Chapter
Slope between D- and E-wave	DEsl	cm/s	RV_DESLP	mm/s	Card M MV and Aorta

- SP measures:

Description	SIGMA		SonoWin®		Chapter
Tricuspid Regurgitation Velocity	TRV	m/s	Reg_V	m/s	Card D Pulmonic Valve
Right Ventricular Right Atrial Gradient	RVRAGr	mmHg	peakPG	mmHg	Card D Pulmonic Valve

K.2.4.3 Continuity equation (Free measurement)

- 2D measures:

Description	SIGMA		SonoWin®		Chapter
Diameter	Diam	cm	DIAM	mm	Card D Pulmonic Valve
Area 1 computed from Diam1	AREA1	cm2	AreaD	cm2	Card D Pulmonic Valve

- SP measures:

Description	SIGMA		SonoWin®		Chapter
Velocity Time Integral 1	VTI1	cm	VTI1	m	Card D Pulmonic Valve
Velocity Time Integral 2	VTI2	cm	VTI2	m	Card D Pulmonic Valve
Area 2 computed from VTI1 and VTI2	AREA2	cm ²	A1	cm ²	Card D Pulmonic Valve
Velocity 1	Vel1	m/sec	V1	m/s	Card D Pulmonic Valve
Velocity 2	Vel2	m/sec	V2	m/s	Card D Pulmonic Valve
Area 2 in cm ² computed from VEL1 and VEL2	AREA2	cm ²	A2	cm ²	Card D Pulmonic Valve

K.2.4.4 Heart rate (SP or TM measurement)

Description	SIGMA		SonoWin®		Chapter
Heart rate on right ventricle	HR	bpm	HR	bpm	Card D Pulmonic Valve

K.3 Vascular measurements

K.3.1 Stenosis Percentage

Description	SIGMA		SonoWin®		Chapter
Velocity on the stenosis	Vel1	m/s	VMT2	m/s	Angio Flow Volume (Vmean)
Velocity before or after the stenosis	Vel2	m/s	VMB2	m/s	Angio Flow Volume (Vmean)
Stenosis	S	%	D1%S	%	Angio Stenosis %

K.3.2 Stenosis Index

Description	SIGMA		SonoWin®		Chapter
Velocity Time Integral	VTI	cm	VTI1	m	Angio Flow Volume (VTI)
Time Average Maximum Velocity	TAMX	m/s	VMB1	m/s	Angio Flow Volume (VTI)
Peak Velocity	PkV	m/s	VMT1	m/s	Angio Flow Volume (VTI)
Stenosis Index	STI	-	STI	-	Angio Flow Volume (VTI)

K.3.3 Volume

Description	SIGMA		SonoWin®		Chapter
Distance 1	d1	cm	Tumor4_L	mm	Small Parts Mamma
Distance 2	d2	cm	Tumor4_H	mm	Small Parts Mamma
Distance 3	d3	cm	Tumor4_W	mm	Small Parts Mamma
Angio Volume	V	cm3	Tumor4_V	mm3	Small Parts Mamma

K.3.4 Volume flow

Description	SIGMA		SonoWin®		Chapter
Mean Velocity Integral	MVI	cm	VTI2	m	Angio Flow Volume (VTI)
Time Average Velocity	TAV	m/s	Vmean1	m/s	Angio Flow Volume (VTI)
Diameter of the vessel	Diam	cm	Diam	mm	Angio Flow Volume (VTI)
Blood Flow	BF	l/mn	FVOL1	l/min	Angio Doppler Auto Trace

K.3.5 Spectral Broadening Index

Description	SIGMA		SonoWin®		Chapter
Velocity Time Integral	VTI	cm	VTI2	m	Angio Flow Volume (VTI)
Time Average Maximum Velocity (Mean Velocity)	TAMX	m/s	MV2	m/s	Angio Doppler Auto Trace
Peak Velocity	PkV	m/s	MV1	m/s	Angio Doppler Auto Trace
Mean Velocity Integral	MVI	cm	VTI1	m	Angio Flow Volume (VTI)
Time Average Velocity	TAV	m/s	Vmean2	m/s	Angio Flow Volume (VTI)
Spectral Broadening Index	SBI	-	SBI	-	Angio Flow Volume (VTI)

K.3.6 Cardiac Output

Description	SIGMA		SonoWin®		Chapter
Velocity Time Integral	VTI	cm	VTI1	m	Angio Flow Volume (VTI)
Diameter of the vessel	Diam	cm	Diam	mm	Angio Doppler Auto Trace
Stroke Volume	SV	ml	SV2	ml	Angio Flow Volume (VTI)
Stroke Volume Index	SI	ml/m ²	CI2	ml/m ²	Angio Flow Volume (VTI)
Cardiac Output	CO	l/min	CO1	l/min	Angio Flow Volume (VTI)
Cardiac Output Index	CI	l/min/m ²	CI1	l/min/m ²	Angio Flow Volume (VTI)

K.3.7 Frequency

Description	SIGMA		SonoWin®		Chapter
Doppler frequency shift	Freq	kHz	Frequ	Hz	Angio Flow Volume (VTI)

K.3.8 Heart rate (SP or TM measurement)

Description	SIGMA		SonoWin®		Chapter
Measured Heart rate	HR	bpm	Vasc_HR	bpm	Angio Flow Volume (VTI)

K.3.9 Continuity Equations

Description	SIGMA		SonoWin®		Chapter
Diameter 1	Diam1	cm	Diam	mm	Angio Doppler Auto Trace
Area 1	AREA1	cm ²	AREA1	mm ²	Angio Doppler Auto Trace
Velocity 1	Vel1	m/s	VpeakS1	m/s	Angio Doppler Auto Trace
Velocity 2	Vel2	m/s	VpeakS2	m/s	Angio Doppler Auto Trace
Area 2 with the Velocity	AREA2	cm ²	AREA1	mm ²	Angio Flow Volume (VTI)
Velocity Time Integral 1	VTI1	cm	VTI1	m	Angio Flow Volume (VTI)
Velocity Time Integral 2	VTI2	cm	VTI2	m	Angio Flow Volume (VTI)
Area 2 with the Velocity Time Integral	AREA2	cm ²	AREA2	mm ²	Angio Flow Volume (VTI)

K.3.10 Resistance Index, Pulsatility Index

Description	SIGMA		SonoWin®		Chapter
Pulsatility Index	PI	-	PI1	-	Angio Doppler Auto Trace
• Mean Velocity	TAMX	m/s	Vmean_P1	m/s	Angio Doppler Auto Trace
• Velocity at Systole	Vels	m/s	VpeakS1	m/s	Angio Doppler Auto Trace
• Velocity at Diastole	Veld	m/s	VED1	m/s	Angio Doppler Auto Trace
• Ratio Velocity Systole/Diastole	Vels/Veld	-	S/D1	-	Angio Doppler Auto Trace
Resistance Index	RI	-	RI1	-	Angio Doppler Auto Trace
• Velocity at Systole	Vels	m/s	VpeakS2	m/s	Angio Doppler Auto Trace
• Velocity at Diastole	Veld	m/s	VED2	m/s	Angio Doppler Auto Trace
• Ratio Velocity Systole/Diastole	Vels/Veld	-	S/D2	-	Angio Doppler Auto Trace

K.4 Obstetric and Gynaecology

K.4.1 2D measures

In the following table, SonoWin[®] defines

Description	SIGMA		SonoWin [®]		Chapter
Last Menstrual Period	LMP	Date	LMP	Date	Patient data
Estimated Birth Date	EBD	Date	EDD	Date	Patient data
Number of Weeks of Amenorrhea	NWA	weeks	DGA	weeks + days	Patient data
Crow Rump Length	CRL	see ^a	CRL, CRL_WEK, CRL_SD	see ^b	Ob Fet 1
Gestational Sac	GES	see <normal><super-script>a<normal>	SAC, SAC_WEK, SAC_SD	see <normal><super-script>b<normal>	Ob Fet 1
Chorion Diameter	ChD	see <normal><super-script>a<normal>	CHD, CHD_WEK, CHD_SD	see <normal><super-script>b<normal>	Ob Fet 1
Biparietal Diameter	BPD	see <normal><super-script>a<normal>	BPD, BPD_WEK, BPD_SD	see <normal><super-script>b<normal>	Ob Fet 1
Binocular Distance	BOD	see <normal><super-script>a<normal>	ORB, ORB_WEK, ORB_SD	see <normal><super-script>b<normal>	Ob Fet 1
Occipital Frontal Diameter	OFD	see <normal><super-script>a<normal>	OFD, OFD_WEK, OFD_SD	see <normal><super-script>b<normal>	Ob Fet 1
Head Circumference	HC	see <normal><super-script>a<normal>	HC, HC_WEK, HC_SD	see <normal><super-script>b<normal>	Ob Fet 1

Description	SIGMA		SonoWin®		Chapter
Transabdominal Diameter	TAD	see <normal><superscript>a<normal>	ATD, ATD_WEK, ATD_SD	see <normal><superscript>b<normal>	Ob Fet 1
Anterior Posterior Diameter	APD	see <normal><superscript>a<normal>	ALD, ALD_WEK, ALS_SD	see <normal><superscript>b<normal>	Ob Fet 1
Abdominal Circumference	AC	see <normal><superscript>a<normal>	AC, AC_WEK, AC_SD	see <normal><superscript>b<normal>	Ob Fet 1
Thoracic Diameter	THD	see <normal><superscript>a<normal>	THD, THD_WEK, THD_SD	see <normal><superscript>b<normal>	Ob Fet 1
Femur Length	FML	see <normal><superscript>a<normal>	FL, FL_WEK, FL_SD	see <normal><superscript>b<normal>	Ob Fet 1
Humerus Length	HuL	see <normal><superscript>a<normal>	HUM, HUM_WEK, HUM_SD	see <normal><superscript>b<normal>	Ob Fet 1
Computed Abdominal Circumference	AC	see <normal><superscript>a<normal>	AC, AC_WEK, AC_SD	see <normal><superscript>b<normal>	Ob Fet 1
Computed Head Circumference	HC	see <normal><superscript>a<normal>	HC, HC_WEK, HC_SD	see <normal><superscript>b<normal>	Ob Fet 1
Cephalic Index (BPD/OFD)	CI	%	CI	%	Ob Fet 1

Description	SIGMA		SonoWin®		Chapter
Head Circumference / Abdominal Circumference	HC/AC	%	HC/AC	%	Ob Fet 1
Femur Length / Abdominal Circumference	FML/AC	%	FL/AC	%	Ob Fet 1
Femur Length / Biparietal Diameter	FML/BPD	%	FL/BPD	%	Ob Fet 1
Foetal Weight in gramms	WEIGHT	g	EFW	g	Ob Fet 1
Uncertainty in gramms	+/-	g	EFW_SD	g	Ob Fet 1
Average Ultrasound Age	AUA	weeks	USGA	weeks + days	Patient data
Average Estimated Birth Date	AEBD	date	USDD	date	Patient data

- This measure is defined on the SIGMA by a distance (in cm), an estimated fetal age (in weeks and days) and an uncertainty (in weeks and days) on the fetal age
- This measure is defined on SonoWin® by a distance (in mm), an estimated fetal age (in weeks and days) and an uncertainty (in weeks and days) on the fetal age

K.4.2 SP measures

K.4.2.1 Heart Rate

Description	SIGMA		SonoWin®		Chapter
Heart rate	HR	bpm	HEART_R	bpm	Ob Fet 1

K.4.2.2 Velocity and Frequency measurement

Description	SIGMA		SonoWin®		Chapter
Velocity ^a	Velocity	m/s	-	-	-
Frequency	Frequency	kHz	-	-	-

- This SIGMA measure is not assigned to a variable in SonoWin®. The user has to assign it manually to SonoWin® parameter.

K.4.2.3 Resistance and Pulsatility Index

- Uterine Left Artery:

Description	SIGMA		SonoWin®		Chapter
Pulsatility Index	PI	-	PI-AUT-I	-	Ob Fet 1
• Mean Velocity	TAMX	m/s	VTAMX-AUT-I	cm/s	Ob Fet 1
• Velocity at Systole	Vels	m/s	Vsyst_AUT-I	cm/s	Ob Fet 1
• Velocity at Diastole	Veld	m/s	Venddiast_AUT-I	cm/s	Ob Fet 1
• Ratio Velocity Systole/Diastole	Vels/Veld	-	S/D_AUT-I	-	Ob Fet 1
Resistance Index	RI	-	RI-AUT-I	-	Ob Fet 1
• Velocity at Systole	Vels	m/s	Vsyst_AUT-I	cm/s	Ob Fet 1
• Velocity at Diastole	Veld	m/s	Venddiast_AUT-I	cm/s	Ob Fet 1
• Ratio Velocity Systole/Diastole	Vels/Veld	-	S/D_AUT-I	-	Ob Fet 1

- Uterine Right Artery:

Description	SIGMA		SonoWin®		Chapter
Pulsatility Index	PI	-	PI-AUT-r	-	Ob Fet 1
• Mean Velocity	TAMX	m/s	VTAMX-AUT-r	cm/s	Ob Fet 1
• Velocity at Systole	Vels	m/s	Vsyst_AUT-r	cm/s	Ob Fet 1
• Velocity at Diastole	Veld	m/s	Venddiast_AUT-r	cm/s	Ob Fet 1
• Ratio Velocity Systole/Diastole	Vels/Veld	-	S/D_AUT-r	-	Ob Fet 1
Resistance Index	RI	-	RI-AUT-r	-	Ob Fet 1
• Velocity at Systole	Vels	m/s	Vsyst_AUT-r	cm/s	Ob Fet 1
• Velocity at Diastole	Veld	m/s	Venddiast_AUT-r	cm/s	Ob Fet 1
• Ratio Velocity Systole/Diastole	Vels/Veld	-	S/D_AUT-r	-	Ob Fet 1

- Umbilical Artery:

Description	SIGMA		SonoWin®		Chapter
Pulsatility Index	PI	-	PI-AUM	-	Ob Fet 1
• Mean Velocity	TAMX	m/s	VTAMX-AUM	cm/s	Ob Fet 1
• Velocity at Systole	Vels	m/s	Vsyst_AUM	cm/s	Ob Fet 1
• Velocity at Diastole	Veld	m/s	Venddiast_AUM	cm/s	Ob Fet 1
• Ratio Velocity Systole/Diastole	Vels/Veld	-	S/D_AUM	-	Ob Fet 1
Resistance Index	RI	-	RI-AUM	-	Ob Fet 1
• Velocity at Systole	Vels	m/s	Vsyst_AUM	cm/s	Ob Fet 1
• Velocity at Diastole	Veld	m/s	Venddiast_AUM	cm/s	Ob Fet 1
• Ratio Velocity Systole/Diastole	Vels/Veld	-	S/D_AUM	-	Ob Fet 1

- Cerebral Artery:

Description	SIGMA		SonoWin®		Chapter
Pulsatility Index	PI	-	PI-ACM	-	Ob Fet 1
• Mean Velocity	TAMX	m/s	VTAMX-ACM	cm/s	Ob Fet 1
• Velocity at Systole	Vels	m/s	Vsyst-ACM	cm/s	Ob Fet 1
• Velocity at Diastole	Veld	m/s	Venddiast_ACM	cm/s	Ob Fet 1
• Ratio Velocity Systole/Diastole	Vels/Veld	-	S/D_ACM	-	Ob Fet 1
Resistance Index	RI	-	RI-ACM	-	Ob Fet 1
• Velocity at Systole	Vels	m/s	Vsyst-ACM	cm/s	Ob Fet 1
• Velocity at Diastole	Veld	m/s	Venddiast_ACM	cm/s	Ob Fet 1
• Ratio Velocity Systole/Diastole	Vels/Veld	-	S/D_ACM	-	Ob Fet 1

K.4.3 Foetal information

Description	SIGMA		SonoWin®		Chapter
Number of pregnancies	GRAVIDITAS	-	GRAV	-	Patient data
Number of birthes having reached time	Term	-	TERM	-	Patient data
Number of premature birthes	Prema	-	PREM	-	Patient data
Number of abortion	Abortion	-	ABORT	-	Patient data
Number of alive infant at birth	Living	-	LIV	-	Patient data
Foetal Cardiac Activity	CARDIAC ACTIVITY	-	card_Act	-	Ob Fet 1
Foetal Movement	FOETAL MOVEMENT	-	MOVE	-	Ob Fet 1
Foetal Breathing	FOETAL BREATHING	-	BREATH	-	Ob Fet 1
Foetal Gender	GENDER	-	SEX	-	Ob Fet 1
Foetal Presentation	PRESENTATION	-	PRES	-	Ob Fet 1

K.5 Radiology Study

K.5.1 Volumes In Abdo 2D Studies

Description	SIGMA		SonoWin®		Chapter
Distance 1	d1	cm	Tumor1_L, Tumor2_L, Tumor1_L, Tumor2_L	mm	Abdomen, Abdomen, Small Parts Mamma Small Parts Mamma
Distance 2	d2	cm	Tumor1_H, Tumor2_H, Tumor1_H, Tumor2_H	mm	Abdomen, Abdomen, Small Parts Mamma Small Parts Mamma
Distance 3	d3	cm	Tumor1_W, Tumor2_W, Tumor1_W, Tumor2_W	mm	Abdomen, Abdomen, Small Parts Mamma Small Parts Mamma
Volume	V	cm3	Tumor1_V, Tumor2_V, Tumor1_V, Tumor1_V	mm3	Abdomen, Abdomen, Small Parts Mamma Small Parts Mamma

K.5.2 Cardiac Outputs

Description	SIGMA		SonoWin®		Chapter
Diameter of the vessel	Diam	cm	DIAM	mm	Card D Mitral Valve

K.5.3 Continuity Equation

Description	SIGMA		SonoWin®		Chapter
Diameter 1	Diam1	cm	Diam	mm	Angio Doppler Auto Trace
Area 1	AREA1	cm2	AREA1	mm2	Angio Doppler Auto Trace

K.5.4 Hip Angles

Description	SIGMA		SonoWin®		Chapter
Alpha angle	Alpha angle	degrees	Alpha	degrees	Pediatrics
Type of the Alpha angle	Type of the Alpha angle	-	TypeForAlpha	-	Pediatrics
Beta Angle	Beta Angle	degrees	Beta	degrees	Pediatrics
Type of the Beta angle	Type of the Beta angle	-	TypeForBeta	-	Pediatrics

K.6 Multiple associations



















Sometimes, several SIGMA data are assigned to the same SonoWin® data. It is the user's responsibility to choose which one will be used.

SonoWin® Item	SIGMA value	Description
AC	OG2DAC	Abdominal circumference
	OG2DCAC	Computed abdominal circumference
AC_SD	OG2DAC_SD	Uncertainty on foetal age estimated from AC
	OG2DCAC_SD	Uncertainty on foetal age estimated from computed AC
AC_WEK	OG2DAC_WEK	Foetal age estimated from AC
	OG2DCAC_WEK	Foetal age estimated from computed AC
CI	AVOTCO_COI	Cardiac index
	AVSPCO_COI	Cardiac index
CO	AVOTCO_CO	Cardiac output
	AVSPCO_CO	Cardiac output
Diam	ANCEQ_D	Diameter for Continuity Equation
	ANDIA	Diameter for Continuity Equation
DIAM	AV2DMVD	Diameter
	MVCE_D	Diameter
	MVD	Diameter
HC	OG2DCHC	Head circumference
	OG2DHC	Head circumference
HC_SD	OG2DCHC_SD	Uncertainty on foetal age estimated from computed HC
	OG2DHC_SD	Uncertainty on foetal age estimated from HC
HC_WEK	OG2DCHC_WEK	Foetal age estimated from computed HC
	OG2DHC_WEK	Foetal age estimated from HC
IVSTS	LVTMIVd_IVS	Inter ventricular septum thickness at diastole
	LVTMIVs_IVS	Inter ventricular septum thickness at systole
MVA	AV2DMVA	Mitral valve area
	MVPHT_Area	Mitral valve area computed from PHT
PEP	AVSPPEP	Aortic valve pre ejection period (SP meas)
	AVTMLPP	Aortic valve pre ejection period (TM meas)
S/D_ACM	OGSPPIC_VeIS/VeID	Ratio syst./diast. velocity medial cerebral artery (computed on PI)
	OGSPRIC_VeIS/VeID	Ratio syst./diast. velocity medial cerebral artery (computed on RI)

SonoWin® Item	SIGMA value	Description
S/D_AUM	OGSPPIU_VeIS/VeID	Ratio syst./diast. velocity umbilical artery (computed on PI)
	OGSPRIU_VeIS/VeID	Ratio syst./diast. velocity umbilical artery (computed on RI)
S/D_AUT-l	OGSPPII_VeIS/VeID	Ratio syst./diast. velocity uterine artery left (computed on PI)
	OGSPRIL_VeIS/VeID	Ratio syst./diast. velocity uterine artery left (computed on RI)
S/D_AUT-r	OGSPPIR_VeIS/VeID	Ratio syst./diast. velocity uterine artery right (computed on PI)
	OGSPRIR_VeIS/VeID	Ratio syst./diast. velocity uterine artery right (computed on RI)
SI	AVOTSV_SI	Stroke volume index computed on left ventricle output trunk
	AVSPSV_SI	Stroke volume index computed on aortic valve
SV	AVOTSV_SV	Stroke volume computed on left ventricle output trunk
	AVSPSV_SV	Stroke volume computed on aortic valve
Venddiast_ACM	OGSPPIC_VeID	Enddiastolic velocity cerebral medial artery computed on PI
	OGSPRIC_VeID	Enddiastolic velocity cerebral medial artery computed on RI
Venddiast_AUM	OGSPPIU_VeID	Enddiastolic velocity umbilical artery computed on PI
	OGSPRIU_VeID	Enddiastolic velocity umbilical artery computed on RI
Venddiast_AUT-l	OGSPPII_VeID	Enddiastolic velocity uterine artery left computed on PI
	OGSPRIL_VeID	Enddiastolic velocity uterine artery left computed on RI
Venddiast_AUT-r	OGSPPIR_VeID	Enddiastolic velocity uterine artery right computed on PI
	OGSPRIR_VeID	Enddiastolic velocity uterine artery right computed on RI
Vpeak1	MVCE_Vel1	Velocity from mitral valve continuity equation
	MVPHT_PKV	Max velocity from mitral valve PHT
VpeakS1	ANCEQ_Vel1	Velocity 1 from vascular continuity equation
	ANPI_Vels	Max Velocity from vascular PI
VpeakS2	ANCEQ_Vel2	Velocity 2 from vascular continuity equation
	ANRI_Vels	Max Velocity from vascular RI
Vsyst_ACM	OGSPPIC_Vels	Systolic velocity cerebri media artery (computed on PI)
	OGSPRIC_Vels	Systolic velocity cerebri media artery (computed on RI)
Vsyst_AUM	OGSPPIU_Vels	Systolic velocity umbilical artery (computed on PI)
	OGSPRIU_Vels	Systolic velocity umbilical artery (computed on RI)
Vsyst_AUT-l	OGSPPII_Vels	Systolic velocity uterine artery left (computed on PI)
	OGSPRIL_Vels	Systolic velocity uterine artery left (computed on RI)
Vsyst_AUT-r	OGSPPIR_Vels	Systolic velocity uterine artery right (computed on PI)
	OGSPRIR_Vels	Systolic velocity uterine artery right (computed on RI)
VTI1	ANCEQ_VTI1	VTI1 from vascular continuity equation
	ANSBI_MVI	MVI from vascular spectral broadening index
	ANSI_VTI	VTI from vascular stenosis index
	ANVTI	VTI from vascular cardiac output
VTI2	ANBF_MVI	MVI from vascular blood flow
	ANCEQ_VTI2	VTI2 from vascular continuity equation
	ANSBI_VTI	VTI from vascular spectral broadening index

Appendix L: Body Markers











L.1 Vascular

1		Neck (chin up)	10		Arm (right)
2		Neck left (head up)	11		Arm (left)
3		Neck right (head up)	12		Back
4		Body female	13		Head (face)
5		Body male	14		Head (left)
6		Body (right)	15		Head (right)
7		Body (left)	16		Neck
8		Leg (back)	17		Eye (right)
9		Leg (front)	18		Eye (left)

L.2 Radiology

Two sets of body markers are gathered under the radio application











- **Abdominal body marker set**

1		Body female	6		Breast
2		Body male	7		Neck (with chin up)
3		Back	8		Neck left (head up)
4		Body (right)	9		Neck right (head up)
5		Body (left)	10		Head (face)

- **Paediatry body marker set**











11		Body	12		Head
----	---	------	----	---	------

L.3 Obstetrics/ Gynaecology

- | | | | | | |
|---|---|-----------------------|----|---|---------------|
| 1 |  | Body | 7 |  | Foetus |
| 2 |  | Body female | 8 |  | Foetus |
| 3 |  | Body pregnant | 9 |  | Foetus |
| 4 |  | Body pregnant (right) | 10 |  | Foetus (back) |
| 5 |  | Body pregnant (left) | 11 |  | Foetus (back) |
| 6 |  | Foetus | | | |

L.4 Cardiology

A set of 10 body markers is available in Cardiology. No scan direction is needed for this type of body markers.

- | | | | | | |
|---|---|--------------------------|----|---|---------------------------------------|
| 1 |  | Parasternal long axis | 6 |  | Apical two chamber view |
| 2 |  | Mitral valve level | 7 |  | Subcostal four chamber view |
| 3 |  | Papillary muscle level | 8 |  | Parasternal short axis |
| 4 |  | High short axis | 9 |  | Subparasternal application parallel |
| 5 |  | Apical four chamber view | 10 |  | Subparasternal application transverse |

Appendix M: Acoustic Output Tables

M.1 Track3 Summary Tables

In the following tables, each transducer/mode combination for which the global maximum displayed MI and/or TI is greater than 1.0, is checked with a "+". For these combinations, details are given in the Acoustic Output Reporting Tables in section L.3.

Shaded fields are combinations which are not supported by SIGMA 110/330.

Table 7-1: Track 3 Summary Table: Possible Operating Modes Mechanical Scanheads

Operating modes	Transducer Model					
	3.5 GP	5.0 GP	7.5 GP	6.5 EV	6.5 MR	14 PV
B-Mode						
M-Mode						
PW-Doppler	√	√				
CW-Doppler						
Color Doppler						
Combined						
Other						

Table 7-2: Track 3 Summary Table: Possible Operating Modes Linear and Convex Probes

Operating modes	Transducer Model						
	3.5 CV	7.5 LV	7.5 LVS	6.5 VMC	3.5 MC	5.0 LV	6.5 MC
B-Mode					√	√	√
M-Mode					√	√	√
PW-Doppler		√	√		√	√	√
CW-Doppler							
Color Doppler	√	√	√	√	√	√	√
Combined							
Other							

Table 7-3: Track 3 Summary Table: Possible Operating Modes Doppler Probes

Operating modes	Transducer Model			
	2 MHz TCD	2 MHz Pen	4 MHz Pen	8 MHz Pen
B-Mode				
M-Mode				
PW-Doppler	√			
CW-Doppler				
Color Doppler				
Combined				
Other				

M.2 Definition of Terms

For each transducer/mode combination checked with a "=" in table 7-1 on page 7-113, table 7-2 on page 7-113 and table 7-3 on page 7-114 an output reporting table is given in Chapter M.3, "Acoustic Output Tables", on page 7-116.

The symbols used in the acoustic output tables are explained below:

MI	mechanical index
TIS_{scan}	soft tissue thermal index in auto-scanning mode
$TIS_{non-scan}$	soft tissue thermal index in non-autoscanning mode
TIB	bone thermal index
TIC	cranial thermal index
A_{aprt}	area of active aperture
$P_{r.3}$	derated rarefactional pressure
W_0	ultrasonic power, in scanned modes ultrasonic power passing through a one centimeter window
$W_{.3}(z)$	derated ultrasonic power at axial distance z
$I_{TA.3}(z)$	derated spatial-peak temporal-average intensity at axial distance z
z_1	axial distance corresponding to the location of $\max[\min(W_{.3}(z), I_{TA.3}(z) \times 1 \text{ cm}^2)]$
z_{bp}	minimum axial distance for measurements (break point depth), $1.69 * \sqrt{A_{aprt}}$
z_{sp}	for MI: axial distance of maximum $I_{TA.3}$ for TIB: axial distance of maximum $I_{TA.6} = z_{B.3}$
$d_{eq}(z)$	equivalent beam diameter at axial distance z, $d_{eq}(z) = [(4/p) (W_0 / I_{TA}(z))]^{0.5}$ where $I_{TA}(z)$ is the temporal-average intensity as a function of z.
f_c	center frequency

Dim. of A_{aprt}	active aperture dimensions for the azimuthal (x) and elevational (y) planes
PD	pulse duration
PRF	pulse repetition frequency
$p_r@PII_{\text{max}}$	peak rarefactional pressure where the spatial-peak pulse intensity integral is maximum
$d_{\text{eq}}@PII_{\text{max}}$	equivalent beam diameter at the point where the spatial-peak pulse intensity integral is maximum
FL	focal length
$I_{\text{PA.3}}@MI_{\text{max}}$	derated pulse-average intensity at the point of maximum MI

M.3 Acoustic Output Tables

The following tables show the detailed measurement results for transducer/mode combinations which have a maximum thermal and/or mechanical index exceeding a value of 1.0:

Transducer Model: 3.5MHz GP

Operating Mode: PW-mode

Index Label		MI	TIS			TIB	TIC	
			scan	non-scan		non-scan		
				$A_{\text{aprt}} \leq 1$	$A_{\text{aprt}} \geq 1$			
Global Maximum Index value		(a)	-	-	< 1.0	2.3	(b)	
Assoc. Acoustic Parameters	$P_{r,3}$	MPa	#					
	W_0	mW		-	-	96.7	#	
	min of $[W_{,3}(z_1), I_{TA,3}(z_1)]$		mW			#		
	z_1	cm				#		
	z_{bp}	cm				#		
	z_{sp}	cm	#				6.25	
	$d_{\text{eq}}(z_{sp})$		cm				0.42	
	f_c		MHz	#	-	-	#	3.07
	Dim. of A_{aprt}	x	cm		-	-	#	1.6
y		cm		-	-	#	1.6	
Other Information	PD		msec	#	-	-	#	10.0
	PRF		Hz	#				
	$p_r@P_{II_{\text{max}}}$		MPa	#				
	$d_{\text{eq}}@P_{II_{\text{max}}}$		cm				0.42	
	Focal Length	FL_x	cm		-	-	#	
		FL_y	cm		-	-	#	
$I_{PA,3}@MI_{\text{max}}$		W/cm ²	#					
Control	application			#	-	-	#	Vasc.
	Doppler frequency		MHz	#	-	-	#	3
	gate size		mm	#	-	-	#	8
	velocity range		kHz	#	-	-	#	3.2
	energy		dB	#	-	-	#	0

Notes:

- (a) This index is not required for this operating mode; see section 4.1.3.1 of the Output Display Standard (NEMA-UD-3).
 - (b) This probe is not intended for transcranial or neonatal cephalic uses.
 - (c) This formulation for TIS is less than that for an alternate formulation in this mode.
- # No data are reported for this operating condition since the global maximum index value is not reported for the reason listed.

Transducer Model: 5.0 MHz GP

Operating Mode: PW-mode

Index Label		MI	TIS			TIB	TIC		
			scan	non-scan		non-scan			
				$A_{aprt} \leq 1$	$A_{aprt} \geq 1$				
Global Maximum Index value		(a)	-	-	< 1.0	1.6	(b)		
Assoc. Acoustic Parameters	$p_{r,3}$	MPa	#						
	W_0	mW		-	-		32.2	#	
	min of [$W_{.3}(z_1)$, $I_{TA,3}(z_1)$]		mW				#		
	z_1	cm				#			
	z_{bp}	cm				#			
	z_{sp}	cm	#				3.29		
	$d_{eq}(z_{sp})$		cm					0.22	
	f_c		MHz	#	-	-	#	4.10	#
	Dim. of A_{aprt}	x	cm		-	-	#	1.14	#
y		cm		-	-	#	1.14	#	
Other Information	PD		msec	#	-	-	#	10.1	#
	PRF		Hz	#					
	$p_r@PII_{max}$		MPa	#					
	$d_{eq}@PII_{max}$		cm					0.21	
	Focal Length	FL_x	cm		-	-	#		#
		FL_y	cm		-	-	#		#
$I_{PA,3}@MI_{max}$		W/cm ²	#						
Control	application			#	-	-	#	Vasc.	#
	Doppler frequency		MHz	#	-	-	#	4	#
	gate size		mm	#	-	-	#	8	#
	velocity range		kHz	#	-	-	#	3.2	#
	energy		dB	#	-	-	#	0	#

Notes:

- (a) This index is not required for this operating mode; see section 4.1.3.1 of the Output Display Standard (NEMA-UD-3).
- (b) This probe is not intended for transcranial or neonatal cephalic uses.
- (c) This formulation for TIS is less than that for an alternate formulation in this mode.
- # No data are reported for this operating condition since the global maximum index value is not reported for the reason listed.

Transducer Model: 7.5 MHz LV

Operating Mode: PW-mode

Index Label		MI	TIS			TIB	TIC	
			scan	non-scan		non-scan		
				$A_{aprt} \leq 1$	$A_{aprt} \geq 1$			
Global Maximum Index value		(a)	-	1.9	-	1.4	(b)	
Assoc. Acoustic Parameters	Pr.3	MPa	#					
	W_0	mW		-		38.3	#	
	min of $[W_{.3}(z_1), I_{TA.3}(z_1)]$		mW		21.0			
	z_1	cm			1.07			
	z_{bp}	cm			1.07			
	z_{sp}	cm	#			1.96		
	$d_{eq}(z_{sp})$		cm				0.31	
	f_c		MHz	#	-	8.19	-	8.19
	Dim. of A_{aprt}	x	cm		-	0.88	-	0.88
y		cm		-	0.45	-	0.45	
Other Information	PD		msec	#	-	10.5	-	10.5
	PRF		Hz	#				
	$p_r@PII_{max}$		MPa	#				
	$d_{eq}@PII_{max}$		cm				0.30	
	Focal Length	FL _x	cm		-	2.06	-	
		FL _y	cm		-	2.06	-	
$I_{PA.3}@MI_{max}$		W/cm ²	#					
Control	application			#	-	Vasc.	-	Vasc.
	Doppler frequency		MHz	#	-	8	-	8
	gate size		mm	#	-	8	-	8
	velocity range		kHz	#	-	3.2	-	3.2
	energy		dB	#	-	0	-	0

Notes:

- (a) This index is not required for this operating mode; see section 4.1.3.1 of the Output Display Standard (NEMA-UD-3).
 - (b) This probe is not intended for transcranial or neonatal cephalic uses.
 - (c) This formulation for TIS is less than that for an alternate formulation in this mode.
- # No data are reported for this operating condition since the global maximum index value is not reported for the reason listed.

Transducer Model: 7.5 MHz LVS

Operating Mode: PW-mode

Index Label		MI	TIS			TIB	TIC		
			scan	non-scan		non-scan			
				$A_{aprt} \leq 1$	$A_{aprt} \geq 1$				
Global Maximum Index value		(a)	-	1.7	-	1.0	(b)		
Assoc. Acoustic Parameters	$p_{r,3}$	MPa	#						
	W_0	mW		-		-	33.7	#	
	min of [$W_{.3}(z_1)$, $I_{TA,3}(z_1)$]		mW			17.0			
	z_1	cm			1.20				
	z_{bp}	cm			1.20				
	z_{sp}	cm	#				2.23		
	$d_{eq}(z_{sp})$	cm					0.30		
	f_c	MHz	#	-	819	-	8.19	#	
	Dim. of A_{aprt}	x	cm		-	0.77	-	0.77	#
y		cm		-	0.65	-	0.65	#	
Other Information	PD	msec	#		10.5	-	10.5	#	
	PRF	Hz	#						
	$p_r@PII_{max}$	MPa	#						
	$d_{eq}@PII_{max}$	cm					0.29		
	Focal Length	FL_x	cm		-	2.34	-		#
		FL_y	cm		-	2.34	-		#
$I_{PA,3}@MI_{max}$	W/cm^2	#							
Control	application		#	-	Vasc.	-	Vasc.	#	
	Doppler frequency	MHz	#	-	8	-	8	#	
	gate size	mm	#	-	8	-	8	#	
	velocity range	kHz	#	-	3.2	-	3.2	#	
	energy	dB	#	-	0	-	0	#	

Notes:

- (a) This index is not required for this operating mode; see section 4.1.3.1 of the Output Display Standard (NEMA-UD-3).
- (b) This probe is not intended for transcranial or neonatal cephalic uses.
- (c) This formulation for TIS is less than that for an alternate formulation in this mode.
- # No data are reported for this operating condition since the global maximum index value is not reported for the reason listed.

Transducer Model: 2 MHz TCD
Operating Mode: PW-mode

Index Label		MI	TIS			TIB	TIC	
			scan	non-scan		non-scan		
				$A_{aprt} \leq 1$	$A_{aprt} \geq 1$			
Global Maximum Index value		(a)	-	-	< 1.0	2.6	2.8	
Assoc. Acoustic Parameters	Pr.3	MPa	#					
	W_0	mW		-	-	69.0	69.0	
	min of $[W_{.3}(z_1), I_{TA.3}(z_1)]$		mW			-		
	z_1	cm				-		
	z_{bp}	cm				-		
	z_{sp}	cm	#			3.85		
	$d_{eq}(z_{sp})$		cm				0.35	
	f_c		MHz	#	-	-	2.04	2.04
	Dim. of A_{aprt}	x	cm		-	-	1.5	1.5
y		cm		-	-	1.5	1.5	
Other Information	PD		msec	#	-	-	10.0	10.0
	PRF		Hz	#				
	$p_r@PII_{max}$		MPa	#				
	$d_{eq}@PII_{max}$		cm				0.34	
	Focal Length	FL _x	cm		-	-	-	4.20
		FL _y	cm		-	-	-	4.20
$I_{PA.3}@MI_{max}$		W/cm ²	#					
Control	application			#	-	-	Vasc.	Vasc.
	Doppler frequency		MHz	#	-	-	2	2
	gate size		mm	#	-	-	8	8
	velocity range		kHz	#	-	-	3.2	3.2
	energy		dB	#	-	-	0	0

Notes:

- (a) This index is not required for this operating mode; see section 4.1.3.1 of the Output Display Standard (NEMA-UD-3).
- (b) This probe is not intended for transcranial or neonatal cephalic uses.
- (c) This formulation for TIS is less than that for an alternate formulation in this mode.
- # No data are reported for this operating condition since the global maximum index value is not reported for the reason listed.

Transducer Model: 3.5 MHz CV

Operating Mode: Color Flow Doppler

Index Label			MI	TIS			TIB	TIC	
				scan	non-scan		non-scan		
					$A_{aprt} \leq 1$	$A_{aprt} \geq 1$			
Global Maximum Index value			(a)	1.1	-	-	-	(b)	
Assoc. Acoustic Parameters	$p_{r,3}$		MPa	#					
	W_{01}		mW		63.8	-		-	#
	min of $[W_{.3}(z_1), I_{TA,3}(z_1)]$		mW				-		
	z_1		cm				-		
	z_{bp}		cm				-		
	z_{sp}		cm	#				-	
	$d_{eq}(z_{sp})$		cm					-	
	f_c		MHz	#	3.1	-	-	-	#
	Dim. of A_{aprt}	x	cm		1.28	-	-	-	#
y		cm		1.20	-	-	-	#	
Other Information	PD		msec	#	3.90				
	PRF		Hz	#					
	$p_r@PII_{max}$		MPa	#					
	$d_{eq}@PII_{max}$		cm					-	
	Focal Length	FL_x	cm		6.40	-	-		#
		FL_y	cm		6.40	-	-		#
$I_{PA,3}@MI_{max}$		W/cm ²	#						
Control	depth		cm	#	15	-	-	-	#
	Doppler frequency		MHz	#	3.10	-	-	-	#
	color depth			#	min.	-	-	-	#
	color angle			#	min.	-	-	-	#
	resolution			#	med	-	-	-	#
	wall filter			#	off	-	-	-	#
	energy			#	0 dB	-	-	-	#
	application			#	Vasc.	-	-	-	#
	velocity range		Hz	#	250	-	-	-	#
	steering angle		degrees	#	0	-	-	-	#

Notes:

- (a) This index is not required for this operating mode; see section 4.1.3.1 of the Output Display Standard (NEMA-UD-3).
- (b) This probe is not intended for transcranial or neonatal cephalic uses.
- (c) This formulation for TIS is less than that for an alternate formulation in this mode.
- # No data are reported for this operating condition since the global maximum index value is not reported for the reason listed.

Transducer Model: 7.5 MHz LV

Operating Mode: Color Flow Doppler

Index Label		MI	TIS			TIB	TIC		
			scan	non-scan		non-scan			
				$A_{aprt} \leq 1$	$A_{aprt} \geq 1$				
Global Maximum Index value		(a)	1.6	-	-	-	(b)		
Assoc. Acoustic Parameters	Pr.3	MPa	#						
	W_{01}	mW		43.6	-		#		
	min of $[W_{.3}(z_1), I_{TA.3}(z_1)]$		mW			-			
	z_1	cm				-			
	z_{bp}	cm				-			
	z_{sp}	cm	#				-		
	$d_{eq}(z_{sp})$		cm				-		
	f_c		MHz	#	6.13	-	-	#	
	Dim. of A_{aprt}	x	cm		0.88	-	-	#	
y		cm		0.45	-	-	#		
Other Information	PD		msec	#	1.40	-	-	-	
	PRF		Hz	#					
	$p_r@PII_{max}$		MPa	#					
	$d_{eq}@PII_{max}$		cm				-		
	Focal Length	FL _x	cm		2.07	-	-	#	
		FL _y	cm		2.07	-	-	#	
$I_{PA.3}@MI_{max}$		W/cm ²	#						
Control	depth		cm	#	4	-	-	-	#
	Doppler frequency		MHz	#	6.1	-	-	-	#
	color depth			#	min.	-	-	-	#
	color angle			#	min.	-	-	-	#
	resolution			#	med	-	-	-	#
	wall filter			#	off	-	-	-	#
	energy			#	0 dB	-	-	-	#
	application			#	Vasc.	-	-	-	#
	velocity range		kHz	#	250	-	-	-	#
	steering angle		degrees	#	0	-	-	-	#

Notes:

- (a) This index is not required for this operating mode; see section 4.1.3.1 of the Output Display Standard (NEMA-UD-3).
 - (b) This probe is not intended for transcranial or neonatal cephalic uses.
 - (c) This formulation for TIS is less than that for an alternate formulation in this mode.
- # No data are reported for this operating condition since the global maximum index value is not reported for the reason listed.

Transducer Model: 7.5 MHz LVS

Operating Mode: Color Flow Doppler

Index Label			MI	TIS			TIB	TIC	
				scan	non-scan		non-scan		
					$A_{aprt} \leq 1$	$A_{aprt} \geq 1$			
Global Maximum Index value			(a)	1.8	-	-	-	(b)	
Assoc. Acoustic Parameters	$p_{r,3}$		MPa	#					
	W_{01}		mW		49.1	-		-	#
	min of $[W_{.3}(z_1), I_{TA,3}(z_1)]$		mW				-		
	z_1		cm				-		
	z_{bp}		cm				-		
	z_{sp}		cm	#				-	
	$d_{eq}(z_{sp})$		cm					-	
	f_c		MHz	#	6.13	-	-	-	#
	Dim. of A_{aprt}	x	cm		0.77	-	-	-	#
y		cm		0.65	-	-	-	#	
Other Information	PD		msec	#	1.40				
	PRF		Hz	#					
	$p_r@PII_{max}$		MPa	#					
	$d_{eq}@PII_{max}$		cm					-	
	Focal Length	FL_x	cm		2.30	-	-		#
		FL_y	cm		2.30	-	-		#
$I_{PA,3}@MI_{max}$		W/cm ²	#						
Control	depth		cm	#	3	-	-	-	#
	Doppler frequency		MHz	#	6.1	-	-	-	#
	color depth			#	min.	-	-	-	#
	color angle			#	min.	-	-	-	#
	resolution			#	med	-	-	-	#
	wall filter			#	off	-	-	-	#
	energy			#	0 dB	-	-	-	#
	application			#	Vasc.	-	-	-	#
	velocity range		kHz	#	250	-	-	-	#
	steering angle		degrees	#	0	-	-	-	#

Notes:

- (a) This index is not required for this operating mode; see section 4.1.3.1 of the Output Display Standard (NEMA-UD-3).
- (b) This probe is not intended for transcranial or neonatal cephalic uses.
- (c) This formulation for TIS is less than that for an alternate formulation in this mode.
- # No data are reported for this operating condition since the global maximum index value is not reported for the reason listed.

Transducer Model: 6.5 MHz VMC

Operating Mode: Color Flow Doppler

Index Label		MI	TIS			TIB	TIC		
			scan	non-scan		non-scan			
				$A_{aprt} \leq 1$	$A_{aprt} \geq 1$				
Global Maximum Index value		(a)	1.5	-	-	-	(b)		
Assoc. Acoustic Parameters	Pr.3	MPa	#						
	W_{01}	mW		43.6	-		#		
	min of $[W_{.3}(z_1), I_{TA.3}(z_1)]$		mW			-			
	z_1	cm				-			
	z_{bp}	cm				-			
	z_{sp}	cm	#				-		
	$d_{eq}(z_{sp})$		cm				-		
	f_c		MHz	#	6.13	-	-	#	
	Dim. of A_{aprt}	x	cm		0.67	-	-	#	
y		cm		0.65	-	-	#		
Other Information	PD		msec	#	1.40				
	PRF		Hz	#					
	$p_r@PII_{max}$		MPa	#					
	$d_{eq}@PII_{max}$		cm				-		
	Focal Length	FL _x	cm		4.06	-	-	#	
		FL _y	cm		4.06	-	-	#	
$I_{PA.3}@MI_{max}$		W/cm ²	#						
Control	depth		cm	#	6	-	-	-	#
	Doppler frequency		MHz	#	6.1	-	-	-	#
	color depth			#	min.	-	-	-	#
	color angle			#	min.	-	-	-	#
	resolution			#	med	-	-	-	#
	wall filter			#	off	-	-	-	#
	energy			#	0 dB	-	-	-	#
	application			#	ObGyn	-	-	-	#
	velocity range		kHz	#	250	-	-	-	#
	steering angle		degrees	#	0	-	-	-	#

Notes:

- (a) This index is not required for this operating mode; see section 4.1.3.1 of the Output Display Standard (NEMA-UD-3).
 - (b) This probe is not intended for transcranial or neonatal cephalic uses.
 - (c) This formulation for TIS is less than that for an alternate formulation in this mode.
- # No data are reported for this operating condition since the global maximum index value is not reported for the reason listed.

Transducer Model: 3.5 MC

Operating Mode: B-mode

Index Label			MI	TIS			TIB	TIC	
				scan	non-scan		non-scan		
					$A_{aprt} \leq 1$	$A_{aprt} \geq 1$			
Global Maximum Index value			1.8	(a)	-	-	-	(a)	
Assoc. Acoustic Parameters	$p_{r,3}$	MPa	2.7						
	W_0	mW		#	-		-	#	
	min of [$W_{.3}(z_1)$, $I_{TA.3}(z_1)$]		mW				-		
	z_1	cm					-		
	z_{bp}	cm					-		
	z_{sp}	cm	3.46				-		
	$d_{eq}(z_{sp})$	cm					-		
	f_c	MHz	2.40	#	-	-	-	#	
	Dim. of A_{aprt}	x	cm		#	-	-	-	#
		y	cm		#	-	-	-	#
Other Information	PD	msec	0.84						
	PRF	Hz	1000						
	$p_r@P_{II_{max}}$	MPa	3.5						
	$d_{eq}@P_{II_{max}}$	cm					-		
	Focal Length	FL_x	cm		#	-	-	#	
		FL_y	cm		#	-	-	#	
	$I_{PA.3}@MI_{max}$		W/cm^2	354.2					
Control	depth	cm	24	#	-	-	-	#	
	frequency	f+ / f-	f-	#	-	-	-	#	
	angle	°	75	#	-	-	-	#	
	focus	cm	3	#	-	-	-	#	

Notes:

- (a) This index is not required for this operating mode; see section 4.1.3.1 of the Output Display Standard (NEMA-UD-3).
- (b) This probe is not intended for transcranial or neonatal cephalic uses.
- (c) This formulation for TIS is less than that for an alternate formulation in this mode.
- # No data are reported for this operating condition since the global maximum index value is not reported for the reason listed.

Transducer Model: 3.5 MC

Operating Mode: M-mode

Index Label		MI	TIS			TIB	TIC	
			scan	non-scan		non-scan		
				$A_{aprt} \leq 1$	$A_{aprt} \geq 1$			
Global Maximum Index value		(a)	-	-	<1.0	1.7	(b)	
Assoc. Acoustic Parameters	Pr.3	MPa	#					
	W_0	mW		-	-	39.4	#	
	min of $[W_{.3}(z_1), I_{TA.3}(z_1)]$		mW			#		
	z_1	cm				#		
	z_{bp}	cm				#		
	z_{sp}	cm	#			3.62		
	$d_{eq}(z_{sp})$		cm				0.33	
	f_c		MHz	#	-	-	#	2.40
	Dim. of A_{aprt}	x	cm		-	-	#	1.09
y		cm		-	-	#	1.20	
Other Information	PD		msec	#		#	0.84	
	PRF		Hz	#				
	$p_r@PII_{max}$		MPa	#				
	$d_{eq}@PII_{max}$		cm				0.33	
	Focal Length	FL_x	cm		-	-	#	#
		FL_y	cm		-	-	#	#
$I_{PA.3}@MI_{max}$		W/cm ²	#					
Control	depth		cm	#	-	-	#	24
	frequency		f+ / f-	#	-	-	#	f-
	focus		cm	#	-	-	#	3

Notes:

- (a) This index is not required for this operating mode; see section 4.1.3.1 of the Output Display Standard (NEMA-UD-3).
 - (b) This probe is not intended for transcranial or neonatal cephalic uses.
 - (c) This formulation for TIS is less than that for an alternate formulation in this mode.
- # is No data are reported for this operating condition since the global maximum index value is not reported for the reason listed.

Transducer Model: 3.5 MC

Operating Mode: PW-mode

Index Label		MI	TIS			TIB	TIC		
			scan	non-scan		non-scan			
				$A_{aprt} \leq 1$	$A_{aprt} \geq 1$				
Global Maximum Index value		(a)	-	-	<1.0	3.2	(b)		
Assoc. Acoustic Parameters	$p_{r,3}$	MPa	#						
	W_0	mW		-	-		93.5	#	
	min of [$W_{.3}(z_1)$, $I_{TA,3}(z_1)$]		mW				#		
	z_1	cm					#		
	z_{bp}	cm					#		
	z_{sp}	cm	#					3.82	
	$d_{eq}(z_{sp})$	cm						0.40	
	f_c	MHz	#	-	-	#	2.05	#	
	Dim. of A_{aprt}	x	cm		-	-	#	1.09	#
y		cm		-	-	#	1.2	#	
Other Information	PD	msec	#			#	10.08	#	
	PRF	Hz	#						
	$p_r@PII_{max}$	MPa	#						
	$d_{eq}@PII_{max}$	cm					0.40		
	Focal Length	FL_x	cm		-	-	#		#
		FL_y	cm		-	-	#		#
$I_{PA,3}@MI_{max}$	W/cm^2	#							
Control	application		#	-	-	#	Vasc.	#	
	Doppler frequency	MHz	#	-	-	#	2	#	
	gate size	mm	#	-	-	#	8	#	
	velocity range	kHz	#	-	-	#	3.2	#	
	energy	dB	#	-	-	#	0	#	

Notes:

- (a) This index is not required for this operating mode; see section 4.1.3.1 of the Output Display Standard (NEMA-UD-3).
- (b) This probe is not intended for transcranial or neonatal cephalic uses.
- (c) This formulation for TIS is less than that for an alternate formulation in this mode.
- # No data are reported for this operating condition since the global maximum index value is not reported for the reason listed.

Transducer Model: 3.5 MC

Operating Mode: Color Flow Doppler

Index Label		MI	TIS			TIB	TIC		
			scan	non-scan		non-scan			
				A _{aprt} ≤1	A _{aprt} ≥1				
Global Maximum Index value		(a)	1.5	-	-	-	(b)		
Assoc. Acoustic Parameters	Pr.3	MPa	#						
	W ₀₁	mW		100.3	-		#		
	min of [W _{.3} (z ₁), I _{TA.3} (z ₁)]		mW			-			
	z ₁		cm			-			
	z _{bp}		cm			-			
	z _{sp}		cm	#			-		
	d _{eq} (z _{sp})		cm				-		
	f _c		MHz	#	3.05	-	-	#	
	Dim. of A _{aprt}	x	cm		1.09	-	-	#	
y		cm		1.20	-	-	#		
Other Information	PD		msec	#	2.95				
	PRF		Hz	#					
	p _r @P _{II} _{max}		MPa	#					
	d _{eq} @P _{II} _{max}		cm				-		
	Focal Length	FL _x	cm		5.08	-	-	#	
		FL _y	cm		5.08	-	-	#	
I _{PA.3} @M _I _{max}		W/cm ²	#						
Control	depth		cm	#	5	-	-	-	#
	Doppler frequency		MHz	#	3.1	-	-	-	#
	color depth			#	min.	-	-	-	#
	color angle			#	min.	-	-	-	#
	resolution			#	hi	-	-	-	#
	wall filter			#	max.	-	-	-	#
	energy		dB	#	0	-	-	-	#
	application			#	Vasc.	-	-	-	#
	velocity range		Hz	#	250	-	-	-	#
	steering angle		degrees	#	0	-	-	-	#

Notes:

- (a) This index is not required for this operating mode; see section 4.1.3.1 of the Output Display Standard (NEMA-UD-3).
 - (b) This probe is not intended for transcranial or neonatal cephalic uses.
 - (c) This formulation for TIS is less than that for an alternate formulation in this mode.
- # No data are reported for this operating condition since the global maximum index value is not reported for the reason listed.

Transducer Model: 5.0 LV

Operating Mode: B-mode

Index Label			MI	TIS			TIB	TIC	
				scan	non-scan		non-scan		
					$A_{aprt} \leq 1$	$A_{aprt} \geq 1$			
Global Maximum Index value			1.5	(a)	-	-	-	(a)	
Assoc. Acoustic Parameters	$p_{r.3}$	MPa	2.9						
	W_0	mW		#	-		-	#	
	min of [$W_{.3}(z_1)$, $I_{TA.3}(z_1)$]		mW				-		
	z_1	cm				-			
	z_{bp}	cm				-			
	z_{sp}	cm	3.11				-		
	$d_{eq}(z_{sp})$	cm					-		
	f_c	MHz	3.88	#	-	-	-	#	
	Dim. of A_{aprt}	x	cm		#	-	-	-	#
		y	cm		#	-	-	-	#
Other Information	PD	msec	0.54						
	PRF	Hz	1000						
	$p_r@PII_{max}$	MPa	4.2						
	$d_{eq}@PII_{max}$	cm					-		
	Focal Length	FL_x	cm		#	-	-	#	
		FL_y	cm		#	-	-	#	
	$I_{PA.3}@MI_{max}$		W/cm ²	342.4					
Control	depth	cm	15	#	-	-	-	#	
	frequency	f+ / f-	f+	#	-	-	-	#	
	angle	°	75	#	-	-	-	#	
	focus	cm	3	#	-	-	-	#	

Notes:

- (a) This index is not required for this operating mode; see section 4.1.3.1 of the Output Display Standard (NEMA-UD-3).
- (b) This probe is not intended for transcranial or neonatal cephalic uses.
- (c) This formulation for TIS is less than that for an alternate formulation in this mode.
- # No data are reported for this operating condition since the global maximum index value is not reported for the reason listed.

Transducer Model: 5.0 LV

Operating Mode: M-mode

Index Label		MI	TIS			TIB	TIC	
			scan	non-scan		non-scan		
				$A_{aprt} \leq 1$	$A_{aprt} \geq 1$			
Global Maximum Index value		(a)	-	-	<1.0	<1.0	(b)	
Assoc. Acoustic Parameters	Pr.3	MPa	#					
	W_0	mW		-	-	#	#	
	min of $[W_{.3}(z_1), I_{TA.3}(z_1)]$		mW			#		
	z_1	cm			#			
	z_{bp}	cm			#			
	z_{sp}	cm	#			#		
	$d_{eq}(z_{sp})$		cm			#		
	f_c		MHz	#	-	-	#	#
	Dim. of A_{aprt}	x	cm		-	-	#	#
y		cm		-	-	#	#	
Other Information	PD		msec	#	-	-	#	#
	PRF		Hz	#				
	$p_r@P_{II_{max}}$		MPa	#				
	$d_{eq}@P_{II_{max}}$		cm				#	
	Focal Length	FL_x	cm		-	-	#	#
		FL_y	cm		-	-	#	#
$I_{PA.3}@M_{I_{max}}$		W/cm ²	#					
Control	depth		#	-	-	#	#	
	frequency		#	-	-	#	#	
	focus		#	-	-	#	#	
			#	-	-	#	#	
			#	-	-	#	#	

Notes:

- (a) This index is not required for this operating mode; see section 4.1.3.1 of the Output Display Standard (NEMA-UD-3).
 - (b) This probe is not intended for transcranial or neonatal cephalic uses.
 - (c) This formulation for TIS is less than that for an alternate formulation in this mode.
- # No data are reported for this operating condition since the global maximum index value is not reported for the reason listed.

Transducer Model: 5.0 LV

Operating Mode: PW-mode

Index Label		MI	TIS			TIB	TIC		
			scan	non-scan		non-scan			
				$A_{\text{aprt}} \leq 1$	$A_{\text{aprt}} \geq 1$				
Global Maximum Index value		(a)	-	-	1.7	3.2	(b)		
Assoc. Acoustic Parameters	$p_{r,3}$	MPa	#						
	W_0	mW		-		-	142.1	#	
	min of [$W_{.3}(z_1)$, $I_{TA,3}(z_1)$]		mW				85.0		
	z_1	cm				1.82			
	z_{bp}	cm				1.82			
	z_{sp}	cm	#				3.54		
	$d_{eq}(z_{sp})$	cm					0.38		
	f_c	MHz	#	-	-	4.10	4.10	#	
	Dim. of A_{aprt}	x	cm		-	-	1.28	1.28	#
y		cm		-	-	0.90	0.90	#	
Other Information	PD	msec	#			10.22	10.22	#	
	PRF	Hz	#						
	$p_r@PII_{\text{max}}$	MPa	#						
	$d_{eq}@PII_{\text{max}}$	cm					0.37		
	Focal Length	FL_x	cm		-	-	3.95		#
		FL_y	cm		-	-	3.95		#
$I_{PA,3}@MI_{\text{max}}$	W/cm^2	#							
Control	application		#	-	-	Vasc.	Vasc.	#	
	Doppler frequency	MHz	#	-	-	4	4	#	
	gate size	mm	#	-	-	8	8	#	
	velocity range	kHz	#	-	-	3.2	3.2	#	
	energy	dB	#	-	-	0	0	#	

Notes:

- (a) This index is not required for this operating mode; see section 4.1.3.1 of the Output Display Standard (NEMA-UD-3).
- (b) This probe is not intended for transcranial or neonatal cephalic uses.
- (c) This formulation for TIS is less than that for an alternate formulation in this mode.
- # No data are reported for this operating condition since the global maximum index value is not reported for the reason listed.

Transducer Model: 5.0 LV

Operating Mode: Color Flow Doppler

Index Label		MI	TIS			TIB	TIC		
			scan	non-scan		non-scan			
				A _{aprt} ≤1	A _{aprt} ≥1				
Global Maximum Index value		(a)	2.0	-	-	-	(b)		
Assoc. Acoustic Parameters	Pr.3	MPa	#						
	W ₀₁	mW		87.5	-		#		
	min of [W _{.3} (z ₁), I _{TA.3} (z ₁)]		mW			-			
	z ₁		cm			-			
	z _{bp}		cm			-			
	z _{sp}		cm	#			-		
	d _{eq} (z _{sp})		cm				-		
	f _c		MHz	#	4.88	-	-	#	
	Dim. of A _{aprt}	x	cm		1.28	-	-	#	
y		cm		0.90	-	-	#		
Other Information	PD		msec	#	1.99				
	PRF		Hz	#					
	p _r @P _{II} _{max}		MPa	#					
	d _{eq} @P _{II} _{max}		cm				-		
	Focal Length	FL _x	cm		3.6	-	-	#	
		FL _y	cm		3.6	-	-	#	
I _{PA.3} @M _I _{max}		W/cm ²	#						
Control	depth		cm	#	3	-	-	-	#
	Doppler frequency		MHz	#	4.9	-	-	-	#
	color depth			#	min.	-	-	-	#
	color angle			#	min.	-	-	-	#
	resolution			#	med	-	-	-	#
	wall filter			#	max.	-	-	-	#
	energy		dB	#	0	-	-	-	#
	application			#	Periph. Vessel	-	-	-	#
	velocity range		Hz	#	250	-	-	-	#
	steering angle		degrees	#	0	-	-	-	#

Notes:

- (a) This index is not required for this operating mode; see section 4.1.3.1 of the Output Display Standard (NEMA-UD-3).
 - (b) This probe is not intended for transcranial or neonatal cephalic uses.
 - (c) This formulation for TIS is less than that for an alternate formulation in this mode.
- # is No data are reported for this operating condition since the global maximum index value is not reported for the reason listed.

Transducer Model: 6.5 MC

Operating Mode: B-mode

Index Label			MI	TIS			TIB	TIC	
				scan	non-scan		non-scan		
					$A_{aprt} \leq 1$	$A_{aprt} \geq 1$			
Global Maximum Index value			1.5	(a)	-	-	-	(a)	
Assoc. Acoustic Parameters	$p_{r,3}$		MPa	3.0					
	W_0		mW		#	-		-	#
	min of [$W_{.3}(z_1)$, $I_{TA.3}(z_1)$]		mW				-		
	z_1		cm				-		
	z_{bp}		cm				-		
	z_{sp}		cm	2.00				-	
	$d_{eq}(z_{sp})$		cm					-	
	f_c		MHz	4.07	#	-	-	-	#
	Dim. of A_{aprt}	x	cm		#	-	-	-	#
		y	cm		#	-	-	-	#
Other Information	PD		msec	0.54					
	PRF		Hz	1000					
	$p_r@P_{II_{max}}$		MPa	4.0					
	$d_{eq}@P_{II_{max}}$		cm					-	
	Focal Length	FL_x	cm		#	-	-		#
		FL_y	cm		#	-	-		#
$I_{PA.3}@MI_{max}$		W/cm ²	312.6						
Control	depth		cm	10	#	-	-	-	#
	frequency		f+ / f-	f-	#	-	-	-	#
	angle		°	75	#	-	-	-	#
	focus		cm	3	#	-	-	-	#

Notes:

- (a) This index is not required for this operating mode; see section 4.1.3.1 of the Output Display Standard (NEMA-UD-3).
- (b) This probe is not intended for transcranial or neonatal cephalic uses.
- (c) This formulation for TIS is less than that for an alternate formulation in this mode.
- # No data are reported for this operating condition since the global maximum index value is not reported for the reason listed.

Transducer Model: 6.5 MC

Operating Mode: M-mode

Index Label		MI	TIS			TIB	TIC	
			scan	non-scan		non-scan		
				$A_{aprt} \leq 1$	$A_{aprt} \geq 1$			
Global Maximum Index value		(a)	-	-	<1.0	<1.0	(b)	
Assoc. Acoustic Parameters	Pr.3	MPa	#					
	W_0	mW		-	-	#	#	
	min of $[W_{.3}(z_1), I_{TA.3}(z_1)]$		mW			#		
	z_1	cm				#		
	z_{bp}	cm				#		
	z_{sp}	cm	#			#		
	$d_{eq}(z_{sp})$		cm				#	
	f_c		MHz	#	-	-	#	#
	Dim. of A_{aprt}	x	cm		-	-	#	#
y		cm		-	-	#	#	
Other Information	PD		msec	#	-	-	#	#
	PRF		Hz	#				
	$p_r@P_{II_{max}}$		MPa	#				
	$d_{eq}@P_{II_{max}}$		cm				#	
	Focal Length	FL _x	cm		-	-	#	#
		FL _y	cm		-	-	#	#
$I_{PA.3}@M_{I_{max}}$		W/cm ²	#					
Control	depth		#	-	-	#	#	#
	frequency		#	-	-	#	#	#
	focus		#	-	-	#	#	#
			#	-	-	#	#	#
			#	-	-	#	#	#

Notes:

- (a) This index is not required for this operating mode; see section 4.1.3.1 of the Output Display Standard (NEMA-UD-3).
 - (b) This probe is not intended for transcranial or neonatal cephalic uses.
 - (c) This formulation for TIS is less than that for an alternate formulation in this mode.
- # No data are reported for this operating condition since the global maximum index value is not reported for the reason listed.

Transducer Model: 6.5 MC

Operating Mode: PW-mode

Index Label		MI	TIS			TIB	TIC		
			scan	non-scan		non-scan			
				$A_{aprt} \leq 1$	$A_{aprt} \geq 1$				
Global Maximum Index value		(a)	-	2.5	-	4.0	(b)		
Assoc. Acoustic Parameters	$p_{r,3}$	MPa	#						
	W_0	mW		-	-	127.4	#		
	min of [$W_{.3}(z_1)$, $I_{TA,3}(z_1)$]		mW			92.8			
	z_1	cm			1.12				
	z_{bp}	cm			1.12				
	z_{sp}	cm	#			2.55			
	$d_{eq}(z_{sp})$	cm				0.37			
	f_c	MHz	#	-	4.10	-	4.10	#	
	Dim. of A_{aprt}	x	cm		-	0.67	-	0.67	#
y		cm		-	0.65	-	0.65	#	
Other Information	PD	msec	#	-	10.08	-	10.08	#	
	PRF	Hz	#						
	$p_r@PII_{max}$	MPa	#						
	$d_{eq}@PII_{max}$	cm					0.35		
	Focal Length	FL_x	cm		-	-	3.07		#
		FL_y	cm		-	-	3.07		#
$I_{PA,3}@MI_{max}$	W/cm^2	#							
Control	application		#	-	-	Vasc.	Vasc.	#	
	Doppler frequency	MHz	#	-	-	4	4	#	
	gate size	mm	#	-	-	8	8	#	
	velocity range	kHz	#	-	-	3.2	3.2	#	
	energy	dB	#	-	-	0	0	#	

Notes:

- (a) This index is not required for this operating mode; see section 4.1.3.1 of the Output Display Standard (NEMA-UD-3).
- (b) This probe is not intended for transcranial or neonatal cephalic uses.
- (c) This formulation for TIS is less than that for an alternate formulation in this mode.
- # No data are reported for this operating condition since the global maximum index value is not reported for the reason listed.

Transducer Model: 6.5 MC

Operating Mode: Color Flow Doppler

Index Label		MI	TIS			TIB	TIC		
			scan	non-scan		non-scan			
				A _{aprt} ≤1	A _{aprt} ≥1				
Global Maximum Index value		(a)	2.5	-	-	-	(b)		
Assoc. Acoustic Parameters	Pr.3	MPa	#						
	W ₀₁	mW		87.1	-		#		
	min of [W _{.3} (z ₁), I _{TA.3} (z ₁)]		mW			-			
	z ₁		cm			-			
	z _{bp}		cm			-			
	z _{sp}		cm	#			-		
	d _{eq} (z _{sp})		cm				-		
	f _c		MHz	#	6.1	-	-	#	
	Dim. of A _{aprt}	x	cm		0.67	-	-	#	
y		cm		0.65	-	-	#		
Other Information	PD		msec	#	1.43				
	PRF		Hz	#					
	p _r @P _{II} _{max}		MPa	#					
	d _{eq} @P _{II} _{max}		cm				-		
	Focal Length	FL _x	cm		3.64	-	-	#	
		FL _y	cm		3.64	-	-	#	
I _{PA.3} @M _I _{max}		W/cm ²	#						
Control	depth		cm	#	2	-	-	-	#
	Doppler frequency		MHz	#	6.1	-	-	-	#
	color depth			#	min.	-	-	-	#
	color angle			#	min.	-	-	-	#
	resolution			#	med	-	-	-	#
	wall filter			#	max	-	-	-	#
	energy		dB	#	0	-	-	-	#
	application			#	Carotid	-	-	-	#
	velocity range		Hz	#	250	-	-	-	#
	steering angle		degrees	#	0	-	-	-	#

Notes:

- (a) This index is not required for this operating mode; see section 4.1.3.1 of the Output Display Standard (NEMA-UD-3).
 - (b) This probe is not intended for transcranial or neonatal cephalic uses.
 - (c) This formulation for TIS is less than that for an alternate formulation in this mode.
- # No data are reported for this operating condition since the global maximum index value is not reported for the reason listed.